

Doc 9157
AN/901



Aerodrome Design Manual

Part 2
**Taxiways, Aprons
and Holding Bays**

Approved by the Secretary General
and published under his authority

Fourth Edition — 2005

International Civil Aviation Organization

Doc 9157
AN/901



Aerodrome Design Manual

Part 2
**Taxiways, Aprons
and Holding Bays**

Approved by the Secretary General
and published under his authority

Fourth Edition — 2005

International Civil Aviation Organization

FOREWORD

In accordance with the provisions in Annex 14, Volume I, States must provide taxiways at an aerodrome. The Annex also recommends the provision of holding bays when the traffic volume is high and the provision of aprons where necessary to permit the on- and off-loading of passengers, cargo or mail as well as the servicing of aircraft without interfering with the aerodrome traffic. The purpose of the following material is to assist States in the implementation of these specifications and thereby help to ensure their uniform application.

With respect to taxiways, the manual includes material on the general layout and description of the design criteria for taxiway physical characteristics, including the shoulder and strips. Several studies have been undertaken on configuration and location of rapid exit taxiways. The existing material on rapid exit taxiways has been updated as a result of studies undertaken by the Secretariat. Additional material on this subject has been added at Appendix 5. The material on fillets describes some methods for fillet design, and detailed information on fillet design has also been included in an appendix. The manual also contains illustrations of diagrams of the impact of newer generation, larger aircraft at existing aerodromes. Additionally, new charts to facilitate deriving of the aircraft wing tip

clearances needed in taxiway/taxilane turning manoeuvres by modern wide body aeroplanes have been added.

The material on holding bays and dual or multiple taxiways, which describes the advantages and disadvantages of the different configurations, is aimed at providing aerodrome controllers with greater flexibility in adjusting the take-off sequence to overcome undue delays. The material concerning aprons describes, inter alia, basic apron layouts, design requirements and the area required for a particular apron layout.

The manual also includes material dealing with segregation of traffic on the movement area. This material describes considerations which should be taken into account when designing aerodrome facilities in order to achieve the maximum practical segregation of aircraft and ground vehicular traffic.

It is intended that the manual be kept up to date. Future editions will most likely be improved on the basis of experience gained and of comments and suggestions received from users of this manual, and readers are therefore invited to give their views, comments and suggestions on this edition. These should be directed to the Secretary General of ICAO.

TABLE OF CONTENTS

	<i>Page</i>		<i>Page</i>
Chapter 1. Taxiways	1-1	1.5 Fillets	1-38
1.1 Taxiway systems	1-1	General	1-38
Functional requirements	1-1	Methods for manoeuvring aircraft on taxiway intersections	1-40
Planning principles	1-1	1.6 Taxiway shoulders and strips	1-40
Stages in taxiway system development ...	1-4	General	1-40
Evaluating taxiway layout alternatives ...	1-7	Treatment	1-41
Aircraft taxi distances	1-8	1.7 Future aircraft developments	1-42
1.2 Physical characteristics design criteria	1-8	General	1-42
General	1-8	Future aircraft trends	1-42
Aerodrome reference code	1-8	Aerodrome data	1-42
Taxiway width	1-9	Taxiway width	1-42
Taxiway curves	1-9	Runway-parallel taxiway separation distance	1-43
Junctions and intersections	1-10	Separation between parallel taxiways	1-43
Taxiway minimum separation distances ...	1-10	Separation distance between taxiway and object	1-44
Parallel taxiway geometry	1-13	Aircraft stand taxilane-to-object	1-45
Aeronautical study relating to minimum separation distances	1-15	Other considerations	1-46
Considerations related to specific functional requirements	1-19	Chapter 2. Holdings bays and other bypasses..	2-1
Notification	1-28	2.1 Need for holding bays and other bypasses	2-1
The effect of new larger aeroplanes on existing airports	1-28	2.2 Types of bypasses	2-1
1.3 Rapid exit taxiways (RETS)	1-30	2.3 Common design requirements and characteristics	2-6
General	1-30	2.4 Size and location of holding bays	2-6
Location and number of exit taxiways ...	1-31	2.5 Holding bay marking and lighting	2-7
Geometric design	1-36	Chapter 3. Aprons	3-1
1.4 Taxiways on bridges	1-36	3.1 Types of aprons	3-1
General	1-36	Passenger terminal apron	3-1
Siting	1-37	Cargo terminal apron	3-1
Dimensions	1-37		
Gradients	1-37		
Bearing strength	1-38		
Lateral restraint	1-38		
Blast protection	1-38		

	<i>Page</i>		<i>Page</i>
Remote parking apron	3-1	Factors affecting the size of the de-icing/anti-icing facility	3-14
Service and hangar aprons	3-1	Factors affecting the number of de-icing/anti-icing pads	3-15
General aviation aprons	3-1	Environmental considerations	3-15
3.2. Design requirements	3-2	Chapter 4. Segregation of traffic on the movement area	4-1
Safety	3-2	4.1 Need for traffic segregation	4-1
Efficiency	3-2	4.2 Activities causing a mix of aircraft and ground vehicles	4-1
Geometry	3-2	4.3 Methods to achieve segregation	4-1
Flexibility	3-2	Exclusion	4-2
Common design characteristics	3-3	Service roads for ground vehicles	4-2
3.3 Basic terminal apron layouts	3-3	Fixed servicing installations	4-2
General considerations	3-3	Markings	4-4
Passenger loading	3-4	Appendix 1. Fillet design	APP 1-1
Passenger terminal apron concepts	3-4	Appendix 2. Jet blast and blast fence considerations	APP 2-1
3.4 Size of aprons	3-7	Appendix 3. Aeroplane classification by code number and letter	APP 3-1
General	3-7	Appendix 4. Taxiway deviation studies	APP 4-1
Aircraft size	3-7	Appendix 5. Design, location and number of rapid exit taxiways	APP 5-1
Traffic volumes	3-8		
Clearance requirements	3-10		
Types of aircraft stand ingress and egress	3-10		
Aircraft ground servicing	3-12		
Taxiways and service roads	3-12		
3.5 Apron guidance	3-12		
3.6 De-icing/anti-icing facilities	3-14		
Location	3-14		

Chapter 1

TAXIWAYS

1.1 TAXIWAY SYSTEMS

Functional requirements

1.1.1 Maximum capacity and efficiency of an aerodrome are realized only by obtaining the proper balance between the need for runways, passenger and cargo terminals, and aircraft storage and servicing areas. These separate and distinct aerodrome functional elements are linked by the taxiway system. The components of the taxiway system therefore serve to link the aerodrome functions and are necessary to develop optimum aerodrome utilization.

1.1.2 The taxiway system should be designed to minimize the restriction of aircraft movement to and from the runways and apron areas. A properly designed system should be capable of maintaining a smooth, continuous flow of aircraft ground traffic at the maximum practical speed with a minimum of acceleration or deceleration. This requirement ensures that the taxiway system will operate at the highest levels of both safety and efficiency.

1.1.3 For any given aerodrome, the taxiway system should be able to accommodate (without significant delay) the demands of aircraft arrivals and departures on the runway system. At low levels of runway utilization the taxiway system can accomplish this with a minimum number of components. However, as the runway acceptance rate increases, the taxiway system capacity must be sufficiently expanded to avoid becoming a factor which limits aerodrome capacity. In the extreme case of runway capacity saturation, when aircraft are arriving and departing at the minimum separation distances, the taxiway system should allow aircraft to exit the runway as soon as practical after landing and to enter the runway just before take-off. This enables aircraft movements on the runway to be maintained at the minimum separation distance.

Planning principles

1.1.4 Runways and taxiways are the least flexible of the aerodrome elements and must therefore be considered

first when planning aerodrome development. Forecasts of future activity should identify changes in the rate of aircraft movements, the nature of the traffic, type of aircraft and any other factors affecting the layout and dimensioning of the runway and taxiway systems. Care should be taken not to place so much attention on the present needs of the system that later phases of development that have equal or greater importance are neglected. For example, if an aerodrome is forecast to serve a higher category of aircraft type in the future, the current taxiway system should be designed to accommodate the greatest separation distances that ultimately will be required (see Table 1-1).

1.1.5 In planning the general layout of the taxiway system, the following principles should be considered:

- a) taxiway routes should connect the various aerodrome elements by the shortest distances, thus minimizing both taxiing time and cost;
- b) taxiway routes should be as simple as possible in order to avoid pilot confusion and the need for complicated instructions;
- c) straight runs of pavement should be used wherever possible. Where changes in direction are necessary, curves of adequate radii, as well as fillets or extra taxiway width, should be provided to permit taxiing at the maximum practical speed (see Section 1.4 and Appendix 1);
- d) taxiway crossings of runways and other taxiways should be avoided whenever possible in the interests of safety and to reduce the potential for significant taxiing delays;
- e) taxiway routings should have as many one-way segments as possible to minimize aircraft conflicts and delay. Taxiway segment flows should be analysed for each configuration under which runway(s) will be used;
- f) the taxiway system should be planned to maximize the useful life of each component so that future

Table 1-1. Design criteria for a taxiway

Physical characteristics	Code letter					
	A	B	C	D	E	F
Minimum width of:						
taxiway pavement	7.5 m	10.5 m	18 m ^a 15 m ^b	23 m ^c 18 m ^d	23 m	25 m
taxiway pavement and shoulder	—	—	25 m	38 m	44 m	60 m
taxiway strip	32.5 m	43 m	52 m	81 m	95 m	115 m
graded portion of taxiway strip	22 m	25 m	25 m	38 m	44 m	60 m
Minimum clearance distance of outer main wheel to taxiway edge	1.5 m	2.25 m	4.5 m ^a 3 m ^b	4.5 m	4.5 m	4.5 m
Minimum separation distance between taxiway centre line and:						
centre line of instrument runway code						
number 1	82.5 m	87 m	—	—	—	—
number 2	82.5 m	87 m	—	—	—	—
number 3	—	—	168 m	176 m	—	—
number 4	—	—	—	176 m	182.5 m	190 m
centre line of non-instrument runway code						
number 1	37.5 m	42 m	—	—	—	—
number 2	47.5 m	52 m	—	—	—	—
number 3	—	—	93 m	101 m	—	—
number 4	—	—	—	101 m	107.5 m	115 m
taxiway centre line object	23.75 m	33.5 m	44 m	66.5 m	80 m	97.5 m
taxiway ^e	16.25 m	21.5 m	26 m	40.5 m	47.5 m	57.5 m
aircraft stand taxilane	12 m	16.5 m	24.5 m	36 m	42.5 m	50.5 m
Maximum longitudinal slope of taxiway:						
pavement	3%	3%	1.5%	1.5%	1.5%	1.5%
change in slope	1% per 25 m	1% per 25 m	1% per 30 m	1% per 30 m	1% per 30 m	1% per 30 m
Maximum transverse slope of:						
taxiway pavement	2%	2%	1.5%	1.5%	1.5%	1.5%
graded portion of taxiway strip upwards	3%	3%	2.5%	2.5%	2.5%	2.5%
graded portion of taxiway strip downwards	5%	5%	5%	5%	5%	5%
ungraded portion of strip upwards or downwards	5%	5%	5%	5%	5%	5%
Minimum radius of longitudinal vertical curve	2 500 m	2 500 m	3 000 m	3 000 m	3 000 m	3 000 m
Minimum taxiway sight distance	150 m from 1.5 m above	200 m from 2 m above	300 m from 3 m above	300 m from 3 m above	300 m from 3 m above	300 m from 3 m above

- a. Taxiway intended to be used by aeroplanes with a wheel base equal to or greater than 18 m.
b. Taxiway intended to be used by aeroplanes with a wheel base less than 18 m.
c. Taxiway intended to be used by aeroplanes with an outer main gear wheel span equal to or greater than 9 m.
d. Taxiway intended to be used by aeroplanes with an outer main gear wheel span less than 9 m.
e. Taxiway other than an aircraft stand taxilane.

phases of development incorporate sections from the current system; and

- g) ultimately, a taxiway system will perform only as well as its least adequate component. Therefore, potential bottlenecks should be identified and eliminated in the planning phase.

1.1.6 Other important considerations when planning a taxiway system include the following:

- a) taxiway routes should avoid areas where the public could have easy access to the aircraft. Security of taxiing aircraft from sabotage or armed aggression should be of primary importance in areas where this is of particular concern;
- b) taxiway layouts should be planned to avoid interference with navigation aids by taxiing aircraft or ground vehicles using the taxiway;
- c) all sections of the taxiway system should be visible from the aerodrome control tower. Remote cameras can be used to monitor sections of taxiways shadowed by terminal buildings or other aerodrome structures if such obstructions cannot be practically avoided;
- d) the effects of jet blast on areas adjacent to the taxiways should be mitigated by stabilizing loose soils and erecting blast fences where necessary to protect people or structures (see Appendix 2); and
- e) the location of taxiways may also be influenced by ILS installations due to interferences to ILS signals by a taxiing or stopped aircraft. Information on critical and sensitive areas surrounding ILS installations is contained in Annex 10, Volume I, Attachment C.

1.1.7 There should be a sufficient number of entrance and exit taxiways serving a specific runway to accommodate the current demand peaks for take-offs and landings. Additional entrances and exits should be designed and developed ahead of expected growth in runway utilization. The following principles apply to the planning of these taxiway system components:

- a) the function of exit taxiways is to minimize the runway occupancy time of landing aircraft. In theory, exit taxiways can be located to best serve each type of aircraft expected to use the runway. In practice, the optimum number and spacing are determined by

grouping the aircraft into a limited number of classes based upon landing speed and deceleration after touchdown;

- b) the exit taxiway should allow an aircraft to move off the runway without restriction to a point clear of the runway, thus allowing another operation to take place on the runway as soon as possible;
- c) an exit taxiway can be either at a right angle to the runway or at an acute angle. The former type requires an aircraft to decelerate to a very low speed before turning off the runway, whereas the latter type allows aircraft to exit the runway at higher speeds, thus reducing the time required on the runway and increasing the runway capacity (details about the location and geometry of the acute angle type [called rapid exit taxiway] are presented in Section 1.3 and Appendix 5); and
- d) a single runway entrance at each end of the runway is generally sufficient to accommodate the demand for take-offs. However if the traffic volume warrants, the use of bypasses, holding bays or multiple runway entrances can be considered (see Chapter 2).

1.1.8 Taxiways located on aprons are divided into two types as follows (see Figure 1-1):

- a) apron taxiway is a taxiway located on an apron and intended either to provide a through taxi route across the apron or to gain access to an aircraft stand taxilane; and
- b) aircraft stand taxilane is a portion of an apron designated as a taxiway and intended to provide access to aircraft stands only.

1.1.9 The requirements for apron taxiways regarding strip width, separation distances, etc., are the same as for any other type of taxiway. The requirements for aircraft stand taxilanes are also the same except for the following modifications:

- a) the transverse slope of the taxilane is governed by the apron slope requirement;
- b) the aircraft stand taxilane does not need to be included in a taxiway strip; and
- c) the requirements for the separation distances from the centre line of the taxilane to an object are less stringent than those for other types of taxiways.

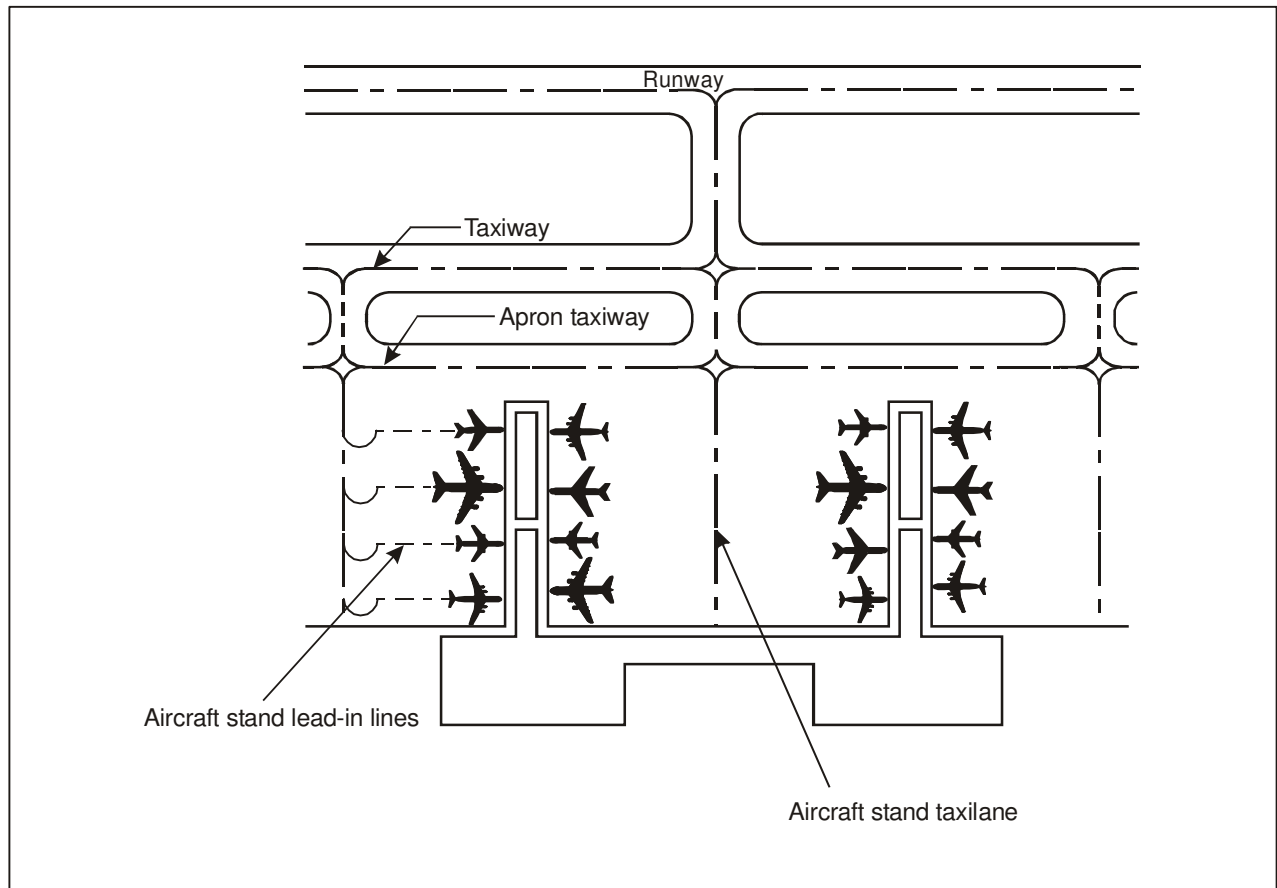

Figure 1-1. Taxiways on aprons

1.1.10 Aircraft stand lead-in lines, which branch off to the parking positions, are not considered to be a part of the aircraft stand taxilane and, therefore, are not subject to the requirements for taxiways.

Stages in taxiway system development

1.1.11 To minimize current construction costs, an aerodrome's taxiway system should be only as complex as needed to support the near-term capacity needs of the runway. With careful planning, additional taxiway components can be added to the system in stages to keep pace with the growth in aerodrome demand. Different stages in taxiway system development are described in the following paragraphs (see also Figures 1-2 and 1-3):

- a) a minimum aerodrome taxiway system, supporting a low level of runway utilization, can consist of only turnaround pads or taxiway turnarounds at both ends of the runway and a stub taxiway from the runway to the apron;
- b) traffic growth which results in a low to moderate level of runway utilization may be accommodated by building a partial parallel taxiway to connect one or both turnarounds (parallel taxiways provide safety benefits as well as greater efficiency);
- c) as runway utilization increases, a full parallel taxiway can be provided by completing the missing sections of the partial parallel taxiway;
- d) exit taxiways, in addition to the ones at each runway end, can be constructed as runway utilization increases toward saturation;
- e) holding bays and bypass taxiways can be added to further enhance runway capacity. These facilities seldom restrict the attainment of full aerodrome capacity within the existing aerodrome property because land is usually available to permit their construction; and

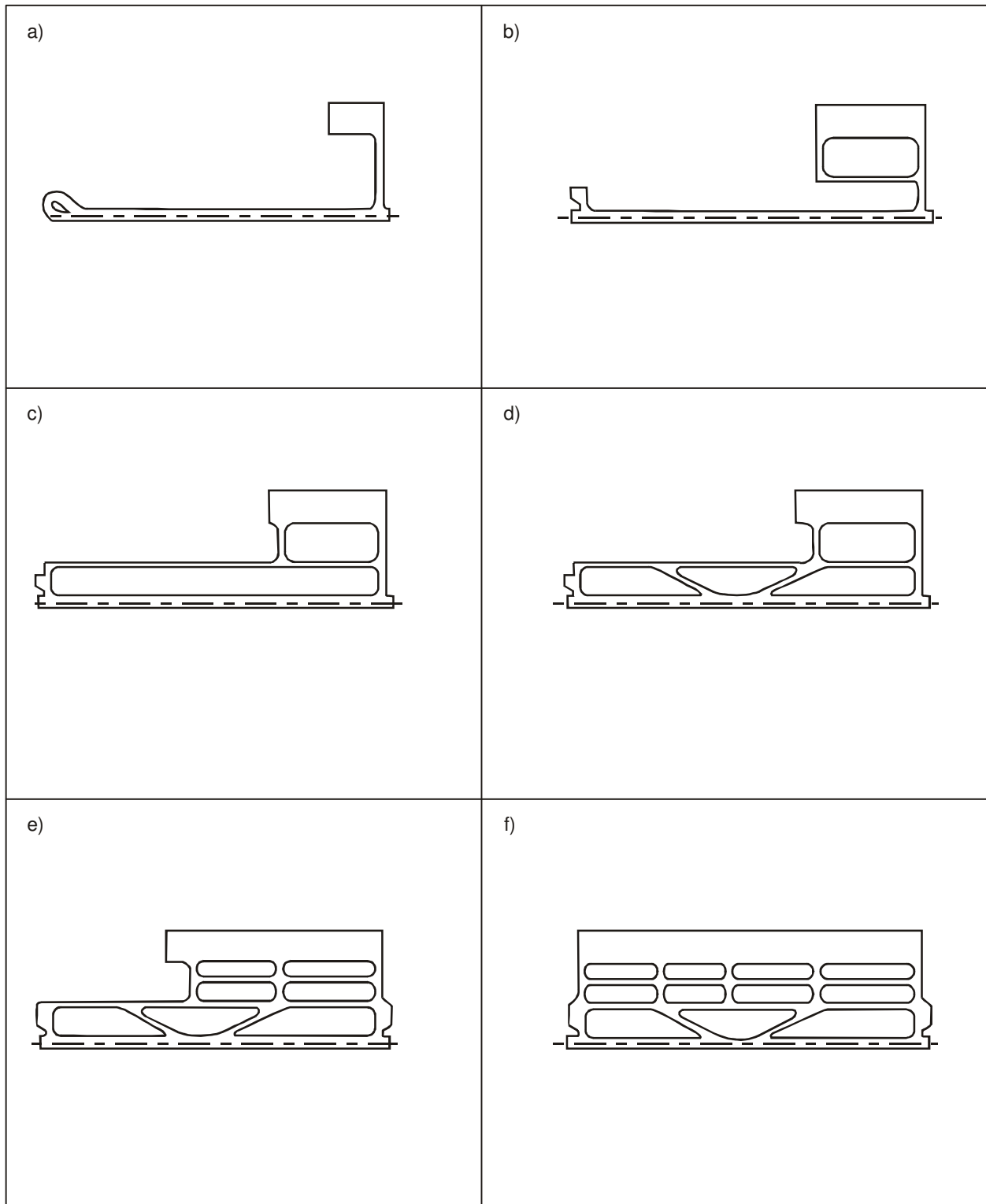

Figure 1-2. Stages in taxiway system development

Diagram a) illustrates a design to minimize the taxiway system. It does not consider the optimum location for the apron which will also need to be taken into account.

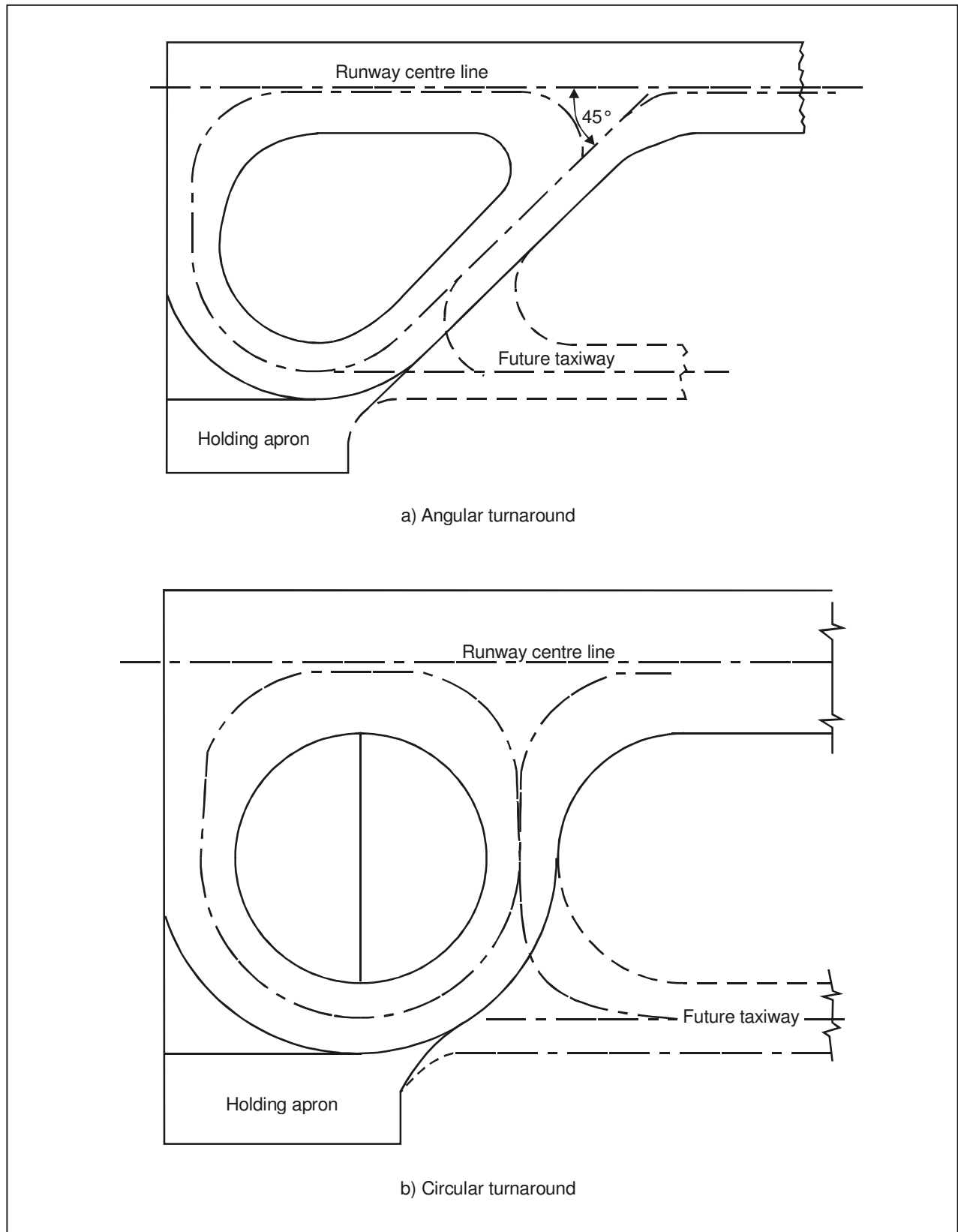

Figure 1-3. Turnarounds

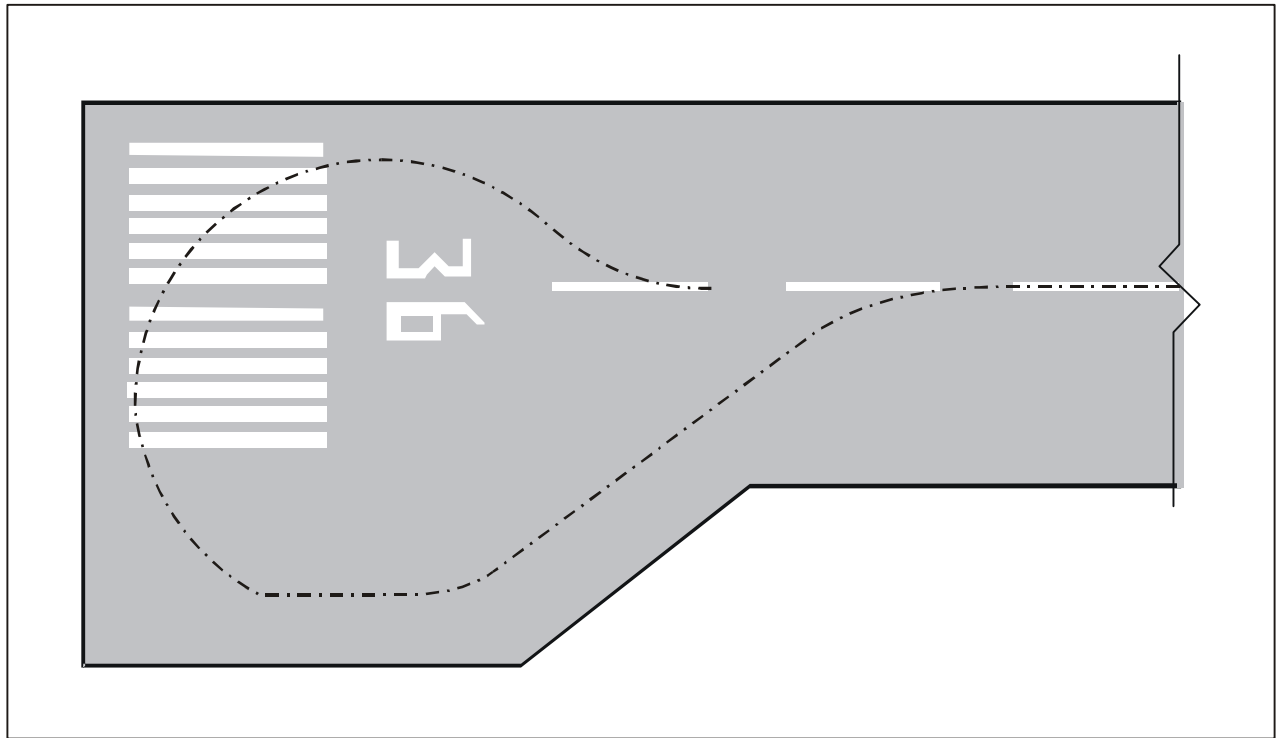

Figure 1-3. (cont.)

- f) a dual-parallel taxiway, located outboard of the first parallel taxiway, should be considered when movement in both directions along the taxiway is desirable. With this second taxiway, a one-way flow network can be established for each direction of runway use. The need for the dual-parallel system increases in proportion to the amount of development alongside the taxiway.

For additional information, see the *Airport Planning Manual* (Doc 9184), Part 1 — Master Planning.

Evaluating taxiway layout alternatives

1.1.12 An evaluation of alternative taxiway systems must take into account the operating efficiency of each system in combination with the runway and apron layouts it is designed to serve. The greater the complexity of the runway, taxiway and apron layouts, the greater the possibility for reducing operating costs through a comparison of alternative taxiway systems. Several computerized aircraft traffic flow simulation models have been developed for this purpose by consultants, aircraft operators and airport authorities.

1.1.13 For example, the United States Federal Aviation Administration has the Airfield Delay Model which simulates all significant aircraft movements performed on an aerodrome and its runway approach paths during an extended period of time. Such models are able to consider a variety of input variables such as:

- aircraft mix;
- traffic volume;
- traffic peaking;
- aerodrome layouts (taxiway and runway);
- terminal destinations of aircraft;
- runway configurations;
- taxiway configurations;
- rapid exit taxiways; and
- use of particular runways by categories of aircraft.

From these inputs, these models produce outputs for evaluation and comparison which include:

- taxiing fuel costs;
- taxiing distances;
- taxiing travel times;
- taxiing delays; and
- runway arrival and departure delays.

Aircraft taxi distances

1.1.14 The main reason to minimize aircraft taxi distances is to reduce taxi time and thus save fuel and enhance aircraft utilization and safety. Of particular importance are the taxi distances for the heavily loaded aircraft taxiing for take-off. Even small airports should have layouts which recognize this need.

1.1.15 At larger airports the issue of aircraft safety has greater significance. Detailed investigations have shown that when a fully laden aircraft is taxied over a distance varying from 3 to 7 km (depending upon the aircraft type, its tire size and type, and the ambient temperature), the tire carcass temperature during take-off can exceed a critical value of 120°C (250°F). Exceeding this critical temperature affects the nylon cord strength and rubber adhesion of the tire and significantly increases the risk of tire failure. The 120°C limit used in the industry applies to taxiing for take-off as well as the take-off run. At 120°C the nylon tensile strength is reduced by 30 per cent. Higher temperatures cause permanent deterioration of rubber adhesive properties. Tire failures during take-off are serious because they can result in an aborted take-off with braking being ineffective on those wheels having blown tires.

1.1.16 Taxi distances should therefore be kept to the minimum practicable. In the case of large wide-bodied aircraft, a distance of 5 km is considered to be the acceptable upper limit, and where unfavourable factors exist, such as those which require frequent use of brakes, this limit may have to be reduced.

1.1.17 Every airport master plan, irrespective of the size of the airport development, should recognize the need to minimize taxi distances, especially for departing aircraft, for both economy and safety. The suitable location of rapid exit taxiways can do much to reduce taxi distances for

landing aircraft. Further, take-offs from taxiway intersections and the use of rapid exit taxiways not only reduce taxi distances and runway occupancy time but also increase runway capacity.

1.2 PHYSICAL CHARACTERISTICS DESIGN CRITERIA

General

1.2.1 Design criteria for taxiways are less stringent than those for runways since aircraft speeds on taxiways are much slower than those on runways. Table 1-1 shows the main physical characteristics design criteria recommended for a taxiway in accordance with the specifications in Annex 14, Volume I. It should be emphasized that with respect to the clearance distance between the outer main wheel of the aircraft and the edge of the taxiway, it is assumed that the cockpit of the aircraft remains over the taxiway centre line markings.

Aerodrome reference code

1.2.2 The reference code is intended to provide a simple method for interrelating the numerous specifications concerning the characteristics of aerodromes to ensure that the aerodrome facilities are suitable for the aeroplanes that are intended to operate at the aerodrome. The code is composed of two elements which are related to the aeroplane performance characteristics and dimensions. Element 1 is a number based on the aeroplane reference field length, and Element 2 is a letter based on the aeroplane wing span and outer main gear wheel span.

1.2.3 A particular specification is related to the more appropriate of the two elements of the code or to an appropriate combination of the two code elements. The code letter or number within an element selected for design purposes is related to the critical aeroplane characteristics for which the facility is provided. When applying the relevant specifications in Annex 14, Volume I the aeroplanes which the aerodrome is intended to serve are identified first followed by the two elements of the code.

1.2.4 An aerodrome reference code — a code number and a letter — selected for aerodrome planning purposes shall be determined in accordance with the characteristics of the aeroplane for which an aerodrome facility is intended. Further, the aerodrome reference code numbers

and letters shall have the meanings assigned to them in Table 1-2. A classification of representative aeroplanes by code number and code letter is included in Appendix 3.

1.2.5 The code number for Element 1 shall be determined from Table 1-2, selecting the code number corresponding to the highest value of the aeroplane reference field lengths of the aeroplanes for which the runway is intended. The aeroplane reference field length is defined as the minimum field length required for take-off at maximum certificated take-off mass, sea level, standard atmospheric conditions, still air and zero runway slope, as shown in the appropriate aeroplane flight manual prescribed by the certificating authority or equivalent data from the aeroplane manufacturer. Accordingly, if 1 650 m corresponds to the highest value of the aeroplane reference field lengths, the code number selected would be “3”.

1.2.6 The code letter for Element 2 shall be determined from Table 1-2, selecting the code letter which corresponds to the greatest wing span, or the greatest outer main gear wheel span, whichever gives the more demanding code letter, of the aeroplanes for which the facility is intended. For instance, if code letter C corresponds to the aeroplane with the greatest wing span and code letter D corresponds to the aeroplane with the greatest outer main gear wheel span, the code letter selected would be “D”.

Taxiway width

1.2.7 Minimum taxiway widths are shown in Table 1-1. The values selected for the minimum taxiway widths are based on adding clearance distance from wheel to pavement edge to the maximum outer main gear wheel span for the selected code letter.

Taxiway curves

1.2.8 Changes in direction of taxiways should be as few and small as possible. The design of the curve should be such that when the cockpit of the aeroplane remains over the taxiway centre line markings, the clearance distance between the outer main wheels of the aeroplane and the edge of the taxiway should not be less than those specified in Table 1-1.

1.2.9 If curves are unavoidable, the radii should be compatible with the manoeuvring capability and normal taxiing speeds of the aircraft for which the taxiway is intended. Table 1-3 shows values of allowable aircraft speeds for given radii of curvature based on a lateral load factor of 0.133 g (see 1.2.22). Where sharp curves are planned and their radii will not suffice to prevent wheels of taxiing aircraft from leaving the pavement, it may be

Table 1-2. Aerodrome reference code

Code element 1		Code element 2		
Code number	Aeroplane reference field length	Code letter	Wing span	Outer main gear wheel span ^a
1	Less than 800 m	A	Up to but not including 15 m	Up to but not including 4.5 m
2	800 m up to but not including 1 200 m	B	15 m up to but not including 24 m	4.5 m up to but not including 6 m
3	1 200 m up to but not including 1 800 m	C	24 m up to but not including 36 m	6 m up to but not including 9 m
4	1 800 m and over	D	36 m up to but not including 52 m	9 m up to but not including 14 m
		E	52 m up to but not including 65 m	9 m up to but not including 14 m
		F	65 m up to but not including 80 m	14 m up to but not including 16 m

a. Distance between the outside edges of the main gear wheels.

Table 1-3. Aircraft speeds versus radius of curve

Speed (km/h)	Radius of curve (m)
16	15
32	60
48	135
64	240
80	375
96	540

necessary to widen the taxiway so as to achieve the wheel clearance specified in Table 1-1. It is to be noted that compound curves may reduce or eliminate the need for extra taxiway width.

Junctions and intersections

1.2.10 To ensure that the minimum wheel clearance distances specified in Table 1-1 are maintained, fillets should be provided at junctions and intersections of taxiways with runways, aprons and other taxiways. Information on the design of fillets is given in 1.5.

Taxiway minimum separation distances

General

1.2.11 The separation distance between the centre line of a taxiway and the centre line of a runway, another taxiway or an object should not be less than the appropriate dimension specified in Table 1-1. It may, however, be permissible to operate with lower separation distances at an existing aerodrome if an aeronautical study indicates that such lower separation distances would not adversely affect the safety or significantly affect the regularity of operations of aeroplanes. Guidance on factors which may be considered in the aeronautical study is given in 1.2.28 through 1.2.66.

1.2.12 The distances are based on the maximum wing span of a group and on the deviation of one aircraft from the taxiway centre line a distance equal to the wheel-to-edge clearance for that group. It should be noted that, even in instances where a particular aircraft design (as a result of an unusual combination of large wing span and narrow gear span) might result in the wing tip extending farther from the centre line distance, the resulting clearance distance would still be considerably more than that required for aircraft to pass.

Separation distances between taxiways, and between taxiways and objects

1.2.13 Formulae and separation distances are shown in Table 1-4 and illustrated in Figure 1-4. The separation distances related to taxiways and apron taxiways are based on the aircraft wing span (Y) and the maximum lateral deviation (X) (the wheel-to-edge clearance specified in Table 1-1).

1.2.14 Lesser distances on aircraft stand taxilanes are considered appropriate because taxiing speeds are normally lower when taxiing on these taxiways, and the increased attention of pilots results in less deviation from the centre line. Accordingly, instead of assuming an aircraft is off the centre line as far as the maximum lateral deviation (X) would allow, a lesser distance is assumed which is referred to as "gear deviation".

1.2.15 It may be noted that two factors have been used in the development of the formulae: the maximum lateral deviation/gear deviation and the wing tip clearance increment. These factors have different functions. The deviation factor represents a distance that aircraft might travel in normal operation. On the other hand, the increment (Z in Figure 1-4) is a safety buffer intended to avoid accidents when aircraft go beyond the taxiway, to facilitate taxiing by providing extra space, and to account for other factors influencing taxiing speeds.

1.2.16 A graduated increment scale rather than a constant increment for all code letters has been selected because:

- a) pilot judgement of clearance distance is more difficult in aircraft with larger wing spans, particularly when the aircraft has swept wings; and
- b) the momentum of larger aircraft may be higher and could result in such aircraft running farther off the edge of a taxiway.

Table 1-4. Minimum separation distances between taxiways and between taxiways and objects (dimensions in metres)

Separation distances	Code letter					
	A	B	C	D	E	F
Between apron taxiway/taxiway centre line and taxiway centre line:						
wing span (Y)	15.00	24.00	36	52.0	65.0	80.0
+ maximum lateral deviation (X)	1.50	2.25	3	4.5	4.5	4.5
+ increment (Z)	7.25	7.25	5	10.0	10.5	13.0
Total separation distance (V)	23.75	33.50	44	66.5	80.0	97.5
Between taxiway centre line and object:						
½ wing span (Y)	7.50	12.00	18	26.0	32.5	40.0
+ maximum lateral deviation (X)	1.50	2.25	3	4.5	4.5	4.5
+ increment (Z)	7.25	7.25	5	10.0	10.5	13.0
Total separation distance (V)	16.25	21.50	26	40.5	47.5	57.5
Between apron taxiway centre line and object:						
½ wing span (Y)	7.50	12.00	18	26.0	32.5	40.0
+ maximum lateral deviation (X)	1.50	2.25	3	4.5	4.5	4.5
+ increment (Z)	7.25	7.25	5	10.0	10.5	13.0
Total separation distance (V)	16.25	21.50	26	40.5	47.5	57.5
Between aircraft stand taxilane centre line and object:						
½ wing span (Y)	7.5	12.00	18.0	26.0	32.5	40.0
+ gear deviation	1.5	1.50	2.0	2.5	2.5	3.0
+ increment (Z)	3.0	3.00	4.5	7.5	7.5	7.5
Total separation distance (V)	12.0	16.50	24.5	36.0	42.5	50.5

1.2.17 The increments for the determination of the separation distances between an apron taxiway and an object are the same as those proposed between a taxiway and an object, the reason being that although apron taxiways are associated with aprons, it is thought that their location should not imply a reduction in taxiing speed. Aircraft will normally be moving at slow speeds on an aircraft stand taxilane and can therefore be expected to remain close to the centre line. Deviations of 1.5, 1.5, 2, 2.5 and 2.5 m have been selected for code letters A to E. A deviation of 2.5 m has also been adopted for code letter F. The use of a graduated scale for lateral deviation in a stand taxilane is considered appropriate since the ability of a pilot to follow the centre line is decreased in larger aircraft because of the cockpit height.

1.2.18 Larger increments have been selected for the separation distances between taxiway/object and apron taxiway/object than for other separation distances. These

larger increments are considered necessary because normally objects along such taxiways are fixed objects, thus making the probability of a collision with one of them greater than that of one aircraft running off the taxiway just as another aircraft is passing that point on the parallel taxiway. Also, the fixed object may be a fence or wall which runs parallel to the taxiway for some distance. Even in the case of a road running parallel to a taxiway, vehicles may unknowingly reduce the clearance distance by parking off the road.

Separation distances between taxiways and runways

1.2.19 The separation distances are based on the concept of the wing of an aircraft centred on a parallel taxiway remaining clear of the associated runway strip. The formulae and separation distances are shown in Table 1-5. The separation distance between the centre lines of a

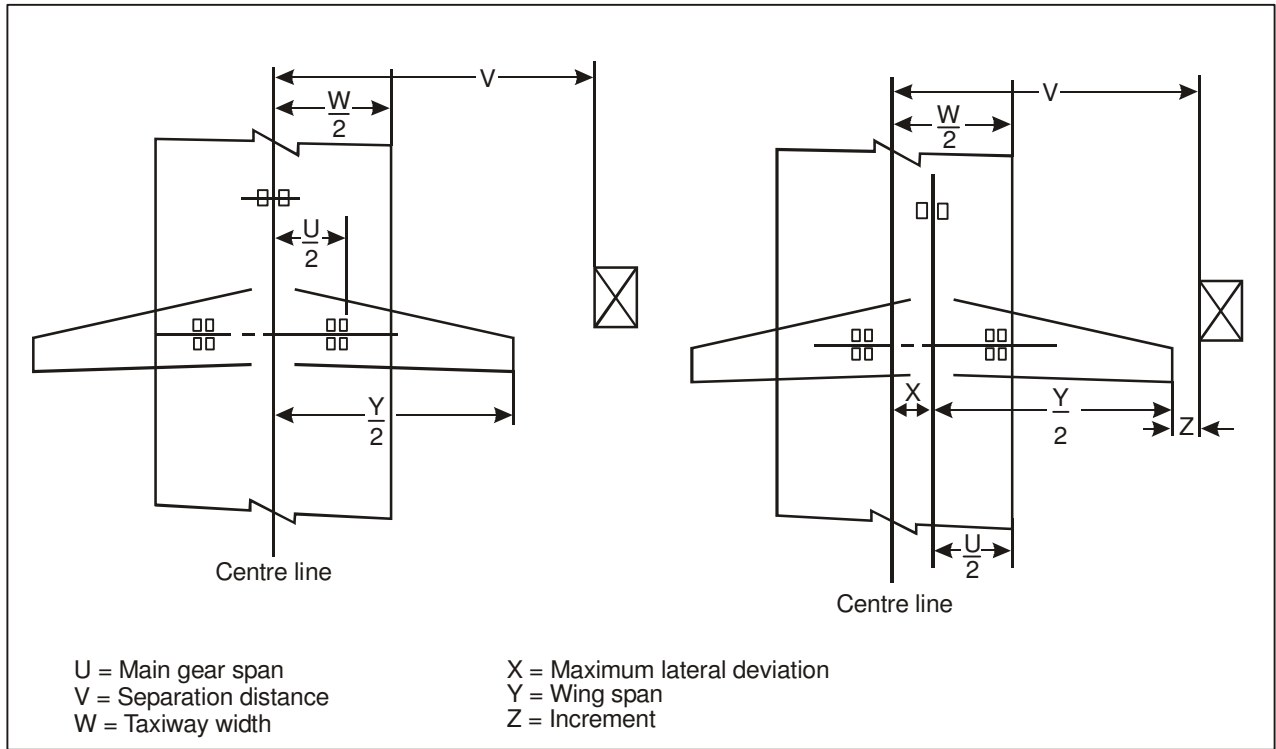

Figure 1-4. Separation distance to an object

Table 1-5. Minimum separation distances between taxiway/apron taxiway centre line and runway centre line (dimensions in metres)

Code number	1		2		3			4				
	A	B	A	B	A	B	C	D	C	D	E	F
½ wing span (Y) + ½ strip width (non-instrument approach runway)	7.5	12	7.5	12	7.5	12	18	26	18	26	32.5	40
Total	37.5	42	47.5	52	82.5	87	93	101	93	101	107.5	115
or												
½ wing span (Y) + ½ strip width (instrument approach runway)	7.5	12	7.5	12	7.5	12	18	26	18	26	32.5	40
Total	82.5	87	82.5	87	157.5	162	168	176	168	176	182.5	190

runway and a parallel taxiway is based on the accepted principle that the wing tip of an aeroplane taxiing on the parallel taxiway should not penetrate the associated runway strip. However this minimum separation distance may not provide adequate length for the link taxiway connecting the parallel taxiway and the runway to permit safe taxiing of another aircraft behind an aircraft holding short of the runway at the holding position. To permit such operations, the parallel taxiway should be so located as to comply with the requirements of Annex 14, Volume I, Tables 3-1 and 3-2, considering the dimensions of the most demanding aeroplane in a given aerodrome code. For example, at a code E aerodrome, this separation would be equal to the sum of the distance of the runway holding position from the taxiway centreline, the overall length of the most demanding aeroplane, the taxiway-to-object distance specified in column E of Table 1-1.

Parallel taxiway geometry

1.2.20 The separation distances between parallel taxiways shown in Table 1-1 have been selected on the basis of desired wing tip clearances. There are other factors which should also be taken into account when evaluating the capability of making a normal 180° turn from one taxiway to another parallel taxiway. These include:

- a) maintaining a reasonable taxi speed to achieve high taxiway system utilization;
- b) maintaining specified clearance distances between the outer main wheel and the taxiway edge when the cockpit remains over the taxiway centre marking; and
- c) manoeuvring at a steering angle that is within the capability of the aircraft and which will not subject the tires to unacceptable wear.

1.2.21 To evaluate the taxi speed when making the 180° turn, it is assumed that the radii of curvature are equal to one-half of the separation distance indicated in Table 1-1, and as shown below:

Code letter	Radius (m)
A	11.875
B	16.75
C	22.0
D	33.25
E	40.0
F	48.75

1.2.22 The velocity in the turn is a function of the radius of the curve (R) and the lateral load factor (f). Thus, if it is assumed that the lateral load factor is limited to 0.133 g:

$$\begin{aligned} V &= (127.133 \times (f) \times R)^{1/2} \\ &= (127.133 \times 0.133 R)^{1/2} \\ &= 4.1120(R^{1/2}), \end{aligned}$$

where R is in metres.

The resulting allowable velocities are shown in Table 1-6.

1.2.23 Examination of Table 1-6 shows that a velocity of 26 km/h is achieved for code letter E. In the case of code letter F, the velocity would be 28.71 km/h. To achieve the same speed on taxiways associated with the other code letters, a separation distance of 80 m would be required. The separation distances for code letters A and B, however, may be unreasonably large when compared with those required by the desired wing tip clearance. In this connection, experience shows that small aircraft require a slower speed than larger aircraft because of their sensitivity to nose gear swivelling.

1.2.24 To evaluate the factors mentioned in 1.2.20 b) and c), a computer programme was developed by an aircraft manufacturer to show the motion of an aircraft during a 180° turn. A representative aircraft from each code letter was used (see Table 1-7). These aircraft were chosen for illustrative purposes because they have the greatest distance between the main gear and the cockpit of the aircraft within each code. The radius of the curve for each case is based on one-half of the minimum separation distance. The outer main gear wheel span is assumed to be the maximum allowed for the code letter, while the table shows the actual aircraft dimension for the distance between the main gear and the cockpit.

1.2.25 The ability to make a smooth turn depends, in part, on the allowable steering angle. Table 1-8 provides data for the representative aircraft. (The data shown in the last column are based on the data of Table 1-7 and assume 3° nose tire slip for Lear 55, F28-2000 and MD80, and 5° nose tire slip for MD11 and B747.) The study revealed that the maximum angle required during the turn is within the limits given in Table 1-8 for all aircraft.

1.2.26 The solution for a 180° turn, which was arrived at by use of a computer programme, can also be determined by graphical means. The procedure requires a step-by-step movement of the cockpit along the centre line of the curve. The main gear is assumed to travel along a

Table 1-6. Allowable velocities in a 180° turn

Code letter	Radius (m)	Velocity $V = 4.1120 (R^{1/2})$ (km/h)
A	11.875	14.17
B	16.75	16.83
C	22.0	19.29
D	33.25	23.71
E	40.0	26.01
F	48.75	28.71

Table 1-7. Assumed data for calculation of 180° turn

Code letter	Aircraft model	Outer main gear wheel span (m)	Main gear to cockpit (m)	Radius of curvature (m)
A	Lear 55	4.5	5.7	11.875
B	F28-2000	6.0	11.9	16.75
C	MD80	9.0	20.3	22.0
D	MD11	14.0	31.0	33.25
E	A340-600	12.0	37.1	
E	B747	14.0	28.0	40.0
E	B777-300	12.9		
F	A380	16.0		48.75

Table 1-8. Aircraft steering angles

Aircraft model	Maximum steering angle	Approx. maximum steering angle during 180° turn
Lear 55	55°	40°
F28-2000	76°	45°
MD80	82°	65°
MD11	70°	60°
B747	70°	50°

line that is formed by the original position of the mid-point between the main gear and the new position of the cockpit. This is illustrated in Figure 1-5.

1.2.27 It is significant to note that the computer programme results were based on increments of movement of 0.5° . This is much too tedious for a graphical solution, and a comparison was made of the computer programme solution with a graphical solution in which the increments were 10° . It was concluded that an error of approximately 2.4 m is introduced by the coarser increments of the graphical method. Increments of 5° will reduce the error to approximately 1.5 m.

Aeronautical study relating to minimum separation distances

Introduction

1.2.28 The aim of the specifications in Annex 14, Volume I is to give aerodrome planners a tool to design efficient aerodromes for safe aircraft operations. It is not intended, however, that the Annex be used to regulate aircraft operations. It may be permissible to operate at

existing aerodromes with lower taxiway separation distances than those specified in the Annex if an aeronautical study indicates that such lower separation distances would not adversely affect the safety or significantly affect the regularity of operations of aircraft. The purpose of this material is to assist States in undertaking an aeronautical study by defining the criteria considered pertinent for the assessment of whether lesser dimensions than those specified in Annex 14, Volume I, Table 3-1 (reproduced in Table 1-1) are adequate for the operation of new larger aeroplanes in the specific operational environment at an existing aerodrome. This may also result in operational restrictions or limitations. Notwithstanding the above, every effort must be made to conform with Annex 14, Volume I specifications at the earliest opportunity.

Objectives and scope

1.2.29 The prime objective of an aeronautical study is to assess the adequacy of the protection provided by the existing layout for the operation of the critical aircraft with respect to:

- a) collision with another aircraft, vehicle or object;

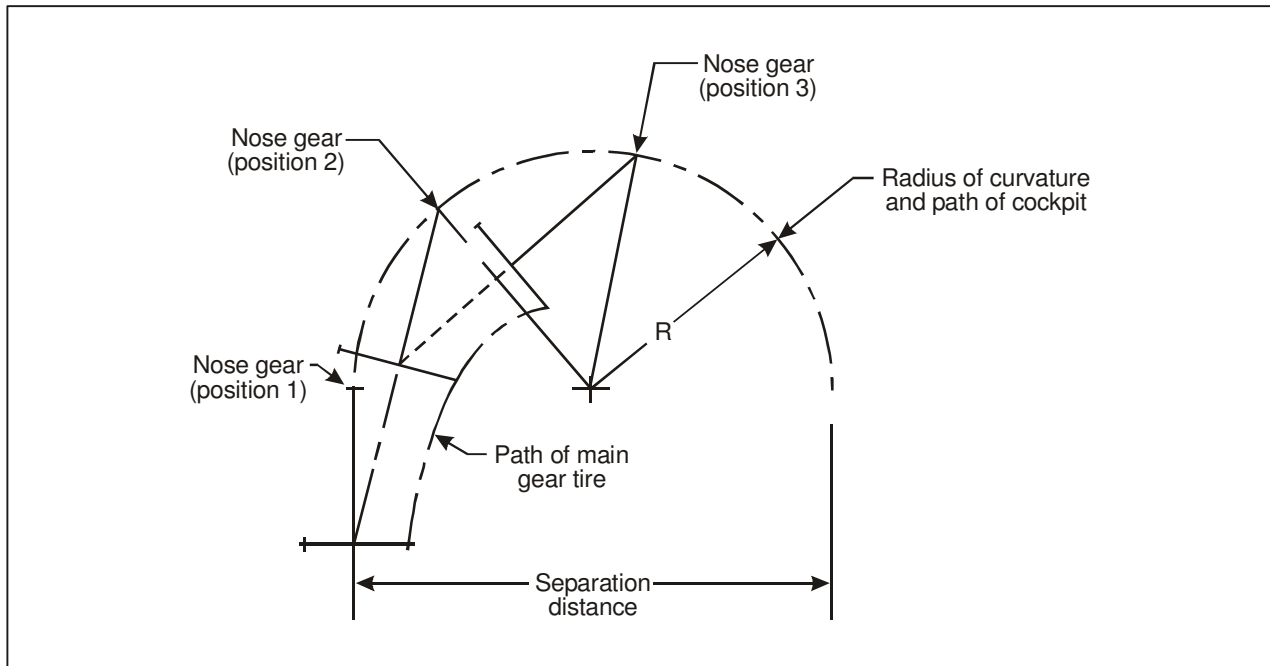

Figure 1-5. Graphical solution of a 180° turn

- b) run-off from paved surfaces; and
- c) engine damage from ingestion.

1.2.30 The areas of concern which this assessment will address relate to specific functional requirements in terms of:

- a) distance between centre line of runway and centre line of taxiway;
- b) distance between centre line of taxiway and centre line of parallel taxiway;
- c) distance between centre line of taxiway and object;
- d) distance between centre line of aircraft stand taxilane and object;
- e) runway and taxiway dimensions, surface and shoulders; and
- f) protection of engines against damage from foreign objects.

It should be noted that every operational factor listed above need not be considered in all instances. Therefore, the appropriate authority should determine which factors are relevant to a risk analysis for a specific site. Additionally, the appropriate authority should define the parameters for each of the operational factors selected and assign a hierarchy of values to each of them, based upon subjective operational and engineering judgements.

Basic considerations

1.2.31 Operational experience with large aircraft at aerodromes not designed to the specifications dictated by that aircraft type has shown that a safe and regular operation is feasible, though subject to specific measures being implemented (e.g. the use of selected taxi routings, designated aircraft stand taxilanes, etc.). This may be due to the fact that a variety of adverse factors do not necessarily affect the operational environment at a certain aerodrome. Furthermore, analyses of accidents and incidents do not indicate that they are caused by inadequate margins that do not meet the specifications in Annex 14, Volume I. It may thus be assumed that the above considerations similarly apply to the operation of new larger aeroplanes, subject to the conditions resulting from the aeronautical study.

Assessment aspects

1.2.32 An aeronautical study will consist essentially of a risk analysis based on pertinent criteria to assess:

- a) probability of collision;
- b) probability of run-off; and
- c) risk of engine ingestion.

The majority of criteria being qualitative in nature, the assessment of risk levels cannot be expressed in absolute or quantitative terms. For the outcome of the study to be meaningful, it should be complemented by operational and engineering judgements. This suggests that the appropriate authority should consult with the aircraft operator when carrying out the assessment.

1.2.33 Referring to collision risk assessment, which addresses the separation/clearance distances provided, the relative risk level on the movement area (expressed in terms of probability of a collision to occur) is generally considered to increase in the following order of priority:

runway → taxiway → apron taxiway →
aircraft stand taxilane

The increase in risk is attributed to:

- a) decreasing accounting for aircraft deviations from the centre line/guideline and associated incremental margins;
- b) increasing density of vehicles and objects; and
- c) increasing complexity of layouts giving rise to pilot distraction, confusion, misinterpretation, etc.

1.2.34 A crucial criterion for assessing the adequacy of existing separation/clearance distances for safe and regular operation of new larger aeroplanes is the accuracy with which aircraft taxi relative to the centre line/guideline on runways and taxiways:

- a) on straight portions; and
- b) on taxiway curves.

1.2.35 The following factors can impact on the accuracy or safety achieved in day-to-day operational environments and require, therefore, a detailed examination as applicable:

- a) quality of aircraft nose wheel guidelines (marking and lighting);
- b) quality of signs;
- c) visibility conditions;
- d) day or night;
- e) surface state (dry, wet, contaminated by snow/ice);
- f) taxi speed;
- g) pilots' attention;
- h) pilots' technique of negotiating turns;
- i) wind effects (cross-wind); and
- j) aircraft handling characteristics.

1.2.36 The provision of taxiing guidance, i.e. marking, lighting and signs which are adequately conspicuous in all operational conditions, together with good surface friction conditions, is considered paramount for achieving a high degree of taxiing accuracy. This is substantiated by the fact that the pilot of a large aeroplane, being unable to see the wing tips, will have to rely primarily on taxiing guidance, the accurate tracking of which will guarantee proper wing tip clearance.

1.2.37 Good surface friction characteristics are required because nose wheel steering effectiveness can become significantly degraded with large aeroplanes whenever the surface is other than dry, thereby challenging the execution of controlled turns. This is particularly true in the presence of a strong cross-wind.

1.2.38 The rationale used for determining separation distances for code letters E and F assumes a lateral deviation value of 4.5 m from the centre line for taxiways/apron taxiways on either straight or curved portions. For aircraft stand taxilanes the respective value is 2.5 m and is referred to as gear deviation.

1.2.39 Taxiway deviation studies, using a representative mix of aircraft types including large aeroplanes, were conducted at London/Heathrow and Amsterdam/Schiphol airports. (See Appendix 4.) Results suggest that in favourable operating conditions (i.e. positive guidance provided by centre line lighting and marking and good surface friction characteristics), the mean deviation of main gears of aircraft from the centre line on straight taxiway portions is less than 4.5 m. It should be noted here, however, that the

value of maximum deviation of main gears of most aircraft reached the 8 to 10 m range depending on aircraft type. With these provisions, a reduction of the deviation value accounted for in an aeronautical study may be acceptable relative to straight portions of taxiways, whereas the specified value should be retained if the above conditions are not met.

1.2.40 For taxiway curves, however, the situation is somewhat different. A fixed deviation of 4.5 m seen as adequate for defining separation/clearance distances does not account for the natural main gear track-in which results from the cockpit following the centre line. For new larger aeroplanes, the track-in allowance may be inadequate for the smaller turn radii of taxiways. Therefore, a detailed evaluation will be required to determine the path followed by the wing tip on the inside of the turn. The paths of the (inner) wing tips of B747-400 and MD11 aircraft are given in Tables 1-9 and 1-10, respectively, and illustrated in Figure 1-6. The maximum wing tip track-in for the newer aircraft, such as the B777-300, MD11, B747-400, B747-200 and A330-300/A340-300 are shown in Figures 1-7 through 1-11, respectively. For a study involving other new larger aeroplanes, it may be necessary to consult the aircraft manufacturers.

1.2.41 Design specifications are based on the assumption that, in taxiway curves, the cockpit is following the centre line of the taxiway. In day-to-day operations, however, pilots frequently use the straight-through or oversteering technique. This alternative practice may be taken into account when contemplating operations with reduced separation/clearance distances. This may apply, for example, in the case of curved parallel taxiways with the aircraft on the outer taxiway using the cockpit over the centre line technique while the aircraft on the inner taxiway applies the oversteering technique (e.g. main gear centre over centre line). Other measures of importance are taxiway turn fillet size and wing tip clearance in the terminal areas.

1.2.42 Apart from assessing the adequacy of separation/clearance distances given the relatively small deviations anticipated in normal operation, the aeronautical study may further require an assessment of the probability of collision due to large inadvertent excursions including run-offs from the paved surface.

1.2.43 Inadvertent excursions are guarded against by using an appropriate safety buffer (increment Z) which, however, does not make a differentiation with regard to the degree of risk involved. Accordingly, it may be assumed that the specified margins will provide adequate protection against a large variety of unfavourable operational factors.

Table 1-9. B747-400 inner wing tip plots (metres)

30 m radius				50 m radius				70 m radius			
Cockpit		Wing tip		Cockpit		Wing tip		Cockpit		Wing tip	
X	Y	X	Y	X	Y	X	Y	X	Y	X	Y
-30.0	0.0	2.5	-45.2	-50.0	0.0	-17.5	-45.2	-70.0	0.0	-37.5	-45.2
-29.5	5.2	2.2	-40.5	-49.2	8.7	-17.9	-37.3	-68.9	12.2	-38.0	-34.1
-28.2	10.3	1.5	-36.8	-47.0	17.1	-18.8	-30.9	-65.8	23.9	-39.0	-24.8
-26.0	15.0	0.5	-34.0	-43.3	25.0	-19.9	-25.5	-60.6	35.0	-39.7	-16.6
-23.0	19.3	-0.7	-31.7	-38.3	32.1	-21.0	-20.8	-53.6	45.0	-40.1	-9.0
-19.3	23.0	-2.2	-30.0	-32.1	38.3	-22.0	-16.4	-45.0	53.6	-39.7	-1.8
-15.0	26.0	-3.9	-28.6	-25.0	43.3	-22.8	-12.3	-35.0	60.6	-38.6	5.1
-10.3	28.2	-5.8	-27.3	-17.1	47.0	-23.3	-8.3	-23.9	65.8	-36.6	11.6
-5.2	29.5	-7.8	-26.1	-8.7	49.2	-23.4	-4.4	-12.2	68.9	-33.7	17.6
0.0	30.0	-10.1	-24.8	0.0	50.0	-23.2	-0.6	0.0	70.0	-29.9	23.1
5.2	30.0	-11.7	-23.0	8.7	50.0	-21.4	3.2	6.1	70.0	-27.3	25.5
10.5	30.0	-12.1	-20.9	17.5	50.0	-17.4	6.6	12.2	70.0	-23.9	27.6
15.7	30.0	-11.5	-18.6	26.2	50.0	-11.8	9.3	18.3	70.0	-19.9	29.5
20.9	30.0	-9.9	-16.4	34.9	50.0	-5.3	11.5	24.4	70.0	-15.3	31.0
26.2	30.0	-7.5	-14.3	43.6	50.0	2.0	13.1	30.5	70.0	-10.4	32.3
31.4	30.0	-4.6	-12.5	54.2	50.0	9.7	14.3	36.7	70.0	-5.2	33.3
36.7	30.0	-1.2	-10.9	61.1	50.0	17.7	15.2	42.8	70.0	0.2	34.1
41.9	30.0	2.6	-9.5	69.8	50.0	25.9	15.8	48.9	70.0	5.7	34.8
47.1	30.0	6.7	-8.3	78.5	50.0	34.2	16.3	55.0	70.0	11.4	35.4
52.4	30.0	11.0	-7.3					61.1	70.0	17.2	35.8
57.6	30.0	15.5	-6.5					67.2	70.0	23.0	36.1
62.8	30.0	20.2	-5.8					73.3	70.0	28.9	36.4
68.1	30.0	24.9	-5.2					79.4	70.0	34.8	36.6
73.3	30.0	29.8	-4.7								
78.5	30.0	34.7	-4.3								

-90 degree turns

-Zero reference point (X = 0, Y = 0) is at turn centre

1.2.44 When contemplating lesser margins, the study will have to determine the relative probability of collision for the particular operational environment at the aerodrome concerned. This entails an assessment of the total risk, composed of:

- a) the risk of run-offs; and
- b) exposure to collision risks;

and for which separate criteria will apply:

for a):

- surface friction conditions
- taxi speed
- straight or curved taxiway
- taxi-in or taxi-out;

for b):

- type of object (fixed/mobile)
- extent or density of objects
- affected part of the movement area.

1.2.45 Expressed in practical terms, the run-off risk is considered to increase with poor surface friction characteristics (snow/ice) where taxi speeds are relatively high, especially in taxiway curves. The exposure to collision risks increases with the aircraft moving from the runway to the apron due to the increase in object density (fixed and mobile) and the smaller margins provided. In a favourable operational environment, however, it may be determined that the probability of collision is extremely remote or improbable and therefore lesser separation/clearance distances are acceptable. This may apply for an isolated object located along a straight taxiway, low taxi speeds and good surface friction characteristics being prevalent.

Table 1-10. MD11 inner wing tip plots (metres)

30 m radius				50 m radius				70 m radius			
Cockpit		Wing tip		Cockpit		Wing tip		Cockpit		Wing tip	
X	Y	X	Y	X	Y	X	Y	X	Y	X	Y
-30.0	0.0	-4.0	-43.0	-50.0	0.0	-24.0	-43.0	-70.0	0.0	-44.0	-43.0
-29.5	5.2	-4.1	-38.1	-49.2	8.7	-24.2	-34.9	-68.9	12.2	-44.2	-31.6
-28.2	10.3	-4.5	-34.0	-47.0	17.1	-24.6	-27.9	-65.8	23.9	-44.5	-21.6
-26.0	15.0	-4.9	-30.6	-43.3	25.0	-24.9	-21.7	-60.6	35.0	-44.4	-12.6
-23.0	19.3	-5.4	-27.8	-38.3	32.1	-25.0	-16.3	-53.6	45.0	-43.6	-4.2
-19.3	23.0	-6.0	-25.5	-32.1	38.3	-24.8	-11.4	-45.0	53.6	-42.1	3.5
-15.0	26.0	-6.6	-23.6	-25.0	43.3	-24.4	6.9	-35.0	60.6	-39.8	10.6
-10.3	28.2	-7.3	-22.0	-17.1	47.0	-23.6	2.8	-23.9	65.8	-36.6	17.1
-5.2	29.5	-8.1	-20.6	-8.7	49.2	-22.6	0.9	-12.2	68.9	-32.5	23.0
0.0	30.0	-9.1	-19.4	0.0	50.0	-21.2	4.4	0.0	70.0	-27.7	28.1
5.2	30.0	-9.7	-18.0	8.7	50.0	-18.6	7.8	6.1	70.0	-24.8	30.4
10.5	30.0	-9.4	-16.2	17.5	50.0	-14.2	11.0	12.2	70.0	-21.1	32.4
15.7	30.0	-8.3	-14.2	26.2	50.0	-8.7	13.8	18.3	70.0	-17.0	34.2
20.9	30.0	-6.5	-12.1	34.9	50.0	-2.2	16.1	24.4	70.0	-12.4	35.8
26.2	30.0	-4.0	-10.2	43.6	50.0	5.0	17.9	30.5	70.0	-7.5	37.2
31.4	30.0	-1.1	-8.3	54.2	50.0	12.6	19.3	36.7	70.0	-2.4	38.3
36.7	30.0	2.3	-6.7	61.1	50.0	20.5	20.4	42.8	70.0	3.0	39.3
41.9	30.0	6.0	-5.2	69.8	50.0	28.6	21.3	48.9	70.0	8.5	40.1
47.1	30.0	10.0	-3.9	78.5	50.0	36.9	21.9	55.0	70.0	14.1	40.8
52.4	30.0	14.2	-2.7	87.3	50.0	45.2	22.4	61.1	70.0	19.8	41.4
57.6	30.0	18.7	-1.8	96.0	50.0	53.7	22.8	67.2	70.0	25.6	41.8
62.8	30.0	23.2	-0.9					73.3	70.0	31.4	42.2
68.1	30.0	27.9	-0.2					79.4	70.0	37.3	42.5
73.3	30.0	32.7	0.5					85.5	70.0	43.3	42.8
78.5	30.0	37.5	1.0					91.6	70.0	49.3	43.0
83.8	30.0	42.4	1.5					97.7	70.0	55.3	43.2
89.0	30.0	47.4	1.8								
94.2	30.0	52.4	2.2								

-90 degree turns

-Zero reference point (X = 0, Y = 0) is at turn centre

Considerations related to specific functional requirements

Runway/taxiway separation distances

1.2.46 The main principle governing runway/taxiway separation distances is that the wing tip of a taxiing aeroplane should not penetrate the strip of the associated runway. Other major aspects requiring consideration concern the protection of an aircraft that has inadvertently run off a runway against collision with another aircraft taxiing on a parallel taxiway and the protection of the ILS critical and sensitive areas against interference from radio nav aids. The risk of a collision occurring is essentially governed by:

- a) the probability of a run-off, and

- b) the exposure to collision risks,

and would have to be assessed in a study for the particular operational environment existing at the aerodrome concerned.

1.2.47 There is statistical evidence that run-offs occur for a variety of causal factors and with different degrees of lateral deviation from the runway centre line. The risk of runway run-offs is significantly due to:

- a) environmental factors:
 - poor runway surface characteristics
 - strong cross-wind/gusts/wind shear;

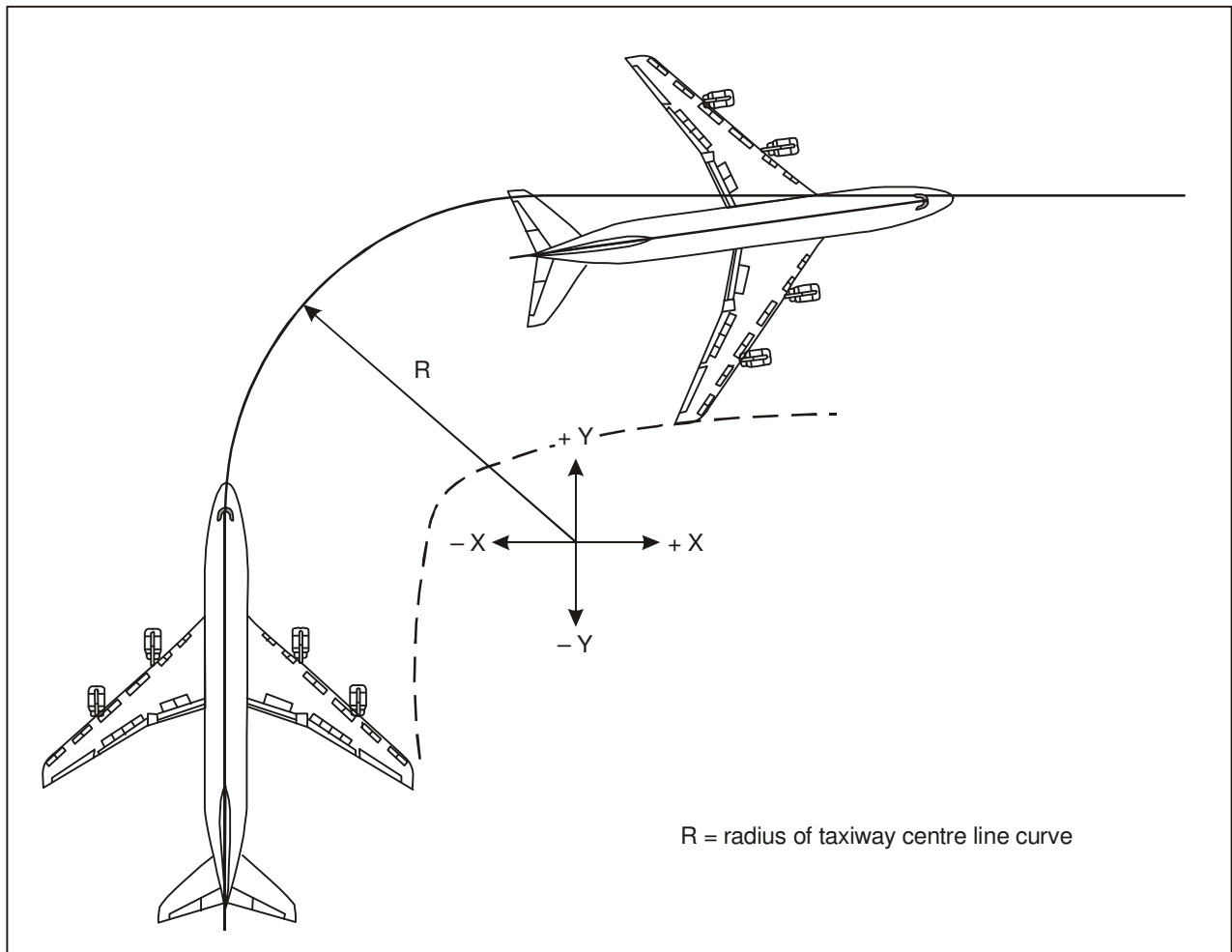

**Figure 1-6. Inner wing tip travel path
(Cockpit over taxiway centre line)**

b) aircraft operation factors:

- human
- technical failures/malfunctions (steering/tire/brake/reverse thrust failures).

1.2.48 While factors related to aircraft operation are in general unpredictable, the environmental factors are subject to control or monitoring by the appropriate authority so that overall risks can be minimized. Furthermore, the exposure to collision risks is largely affected by the magnitude of lateral deviation from the runway centre line and the traffic density.

1.2.49 Guidance on grading of strips for precision approach runways, taking into account lateral deviations, is provided in Annex 14, Volume I, Attachment A, 8.3 and Figure A-3. Relating the lateral dimensions to the existing separation distance may assist in assessing the relative exposure to collision risks. For lesser separation distances than those specified in Annex 14, Volume I, however, it would appear advisable to make efforts to minimize run-off risks through effective control and reporting of runway surface friction characteristics and reliable reporting of wind conditions. Accordingly, aircraft operators can contribute to minimizing run-off risks by applying operational restrictions commensurate with reported conditions.

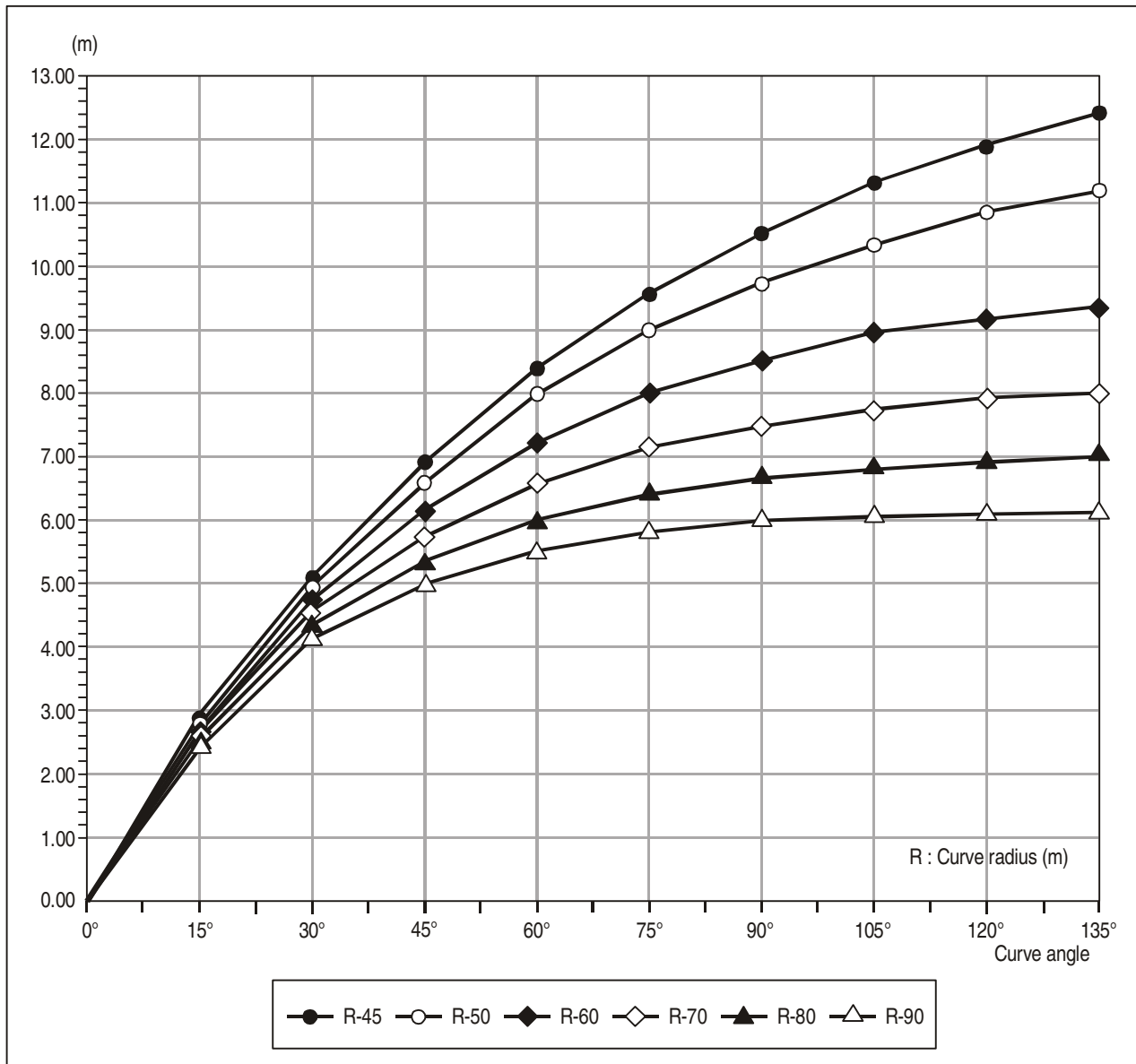

Figure 1-7. Maximum wing tip track-in as a function of curve radius 'R' and curve angle for B777-300

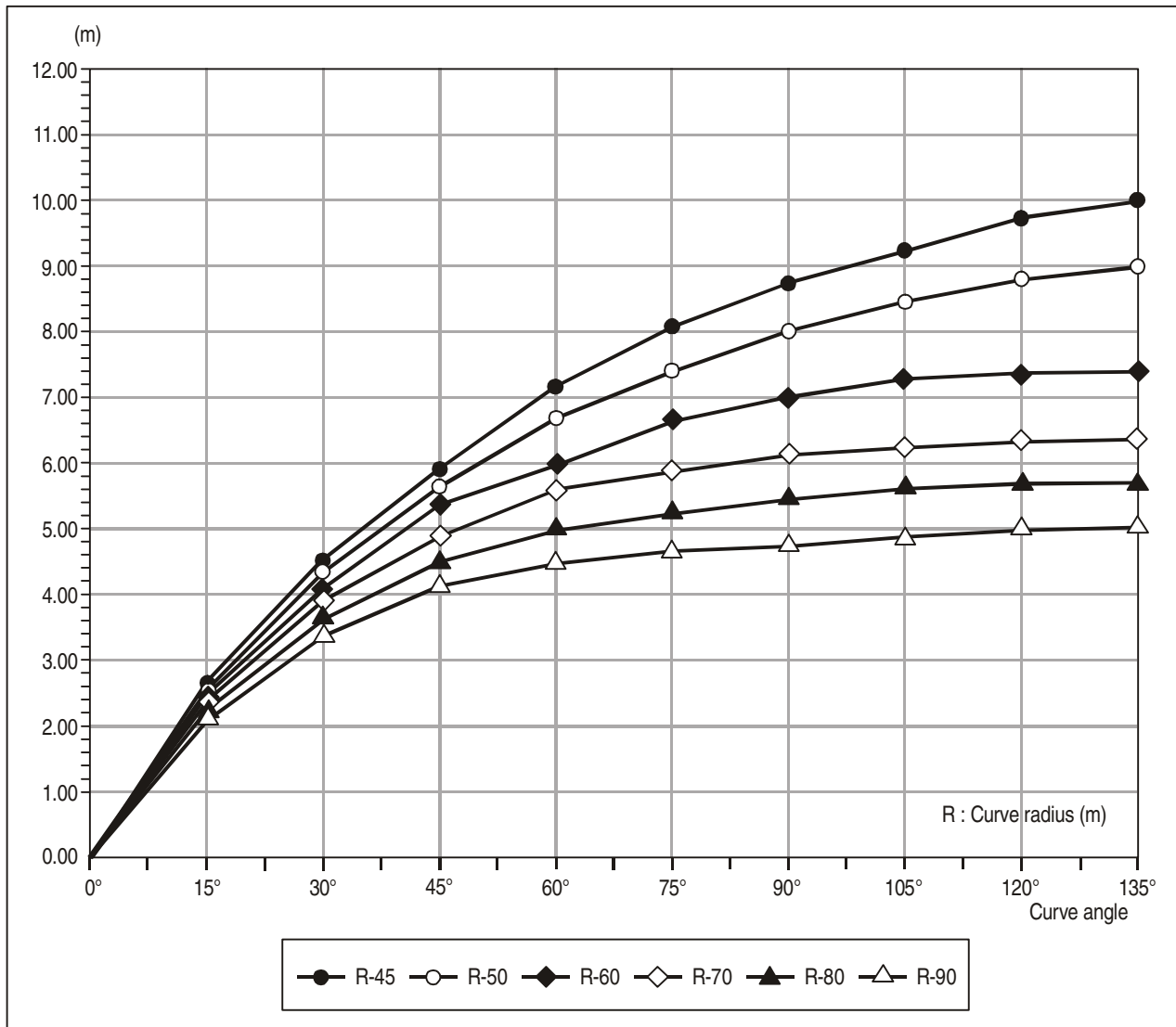

Figure 1-8. Maximum wing tip track-in as a function of curve radius ‘R’ and curve angle for MD11

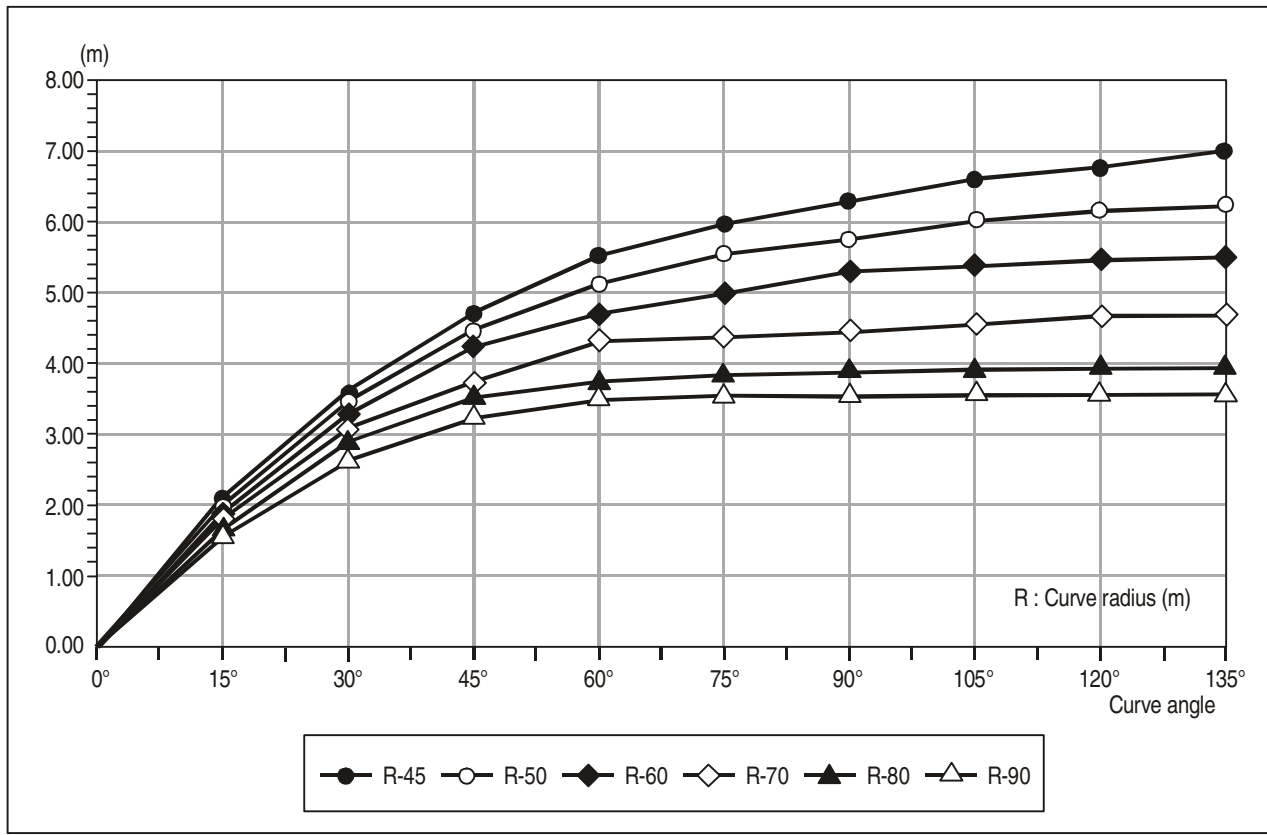

Figure 1-9. Maximum wing tip track-in as a function of curve radius 'R' and curve angle for B747-400

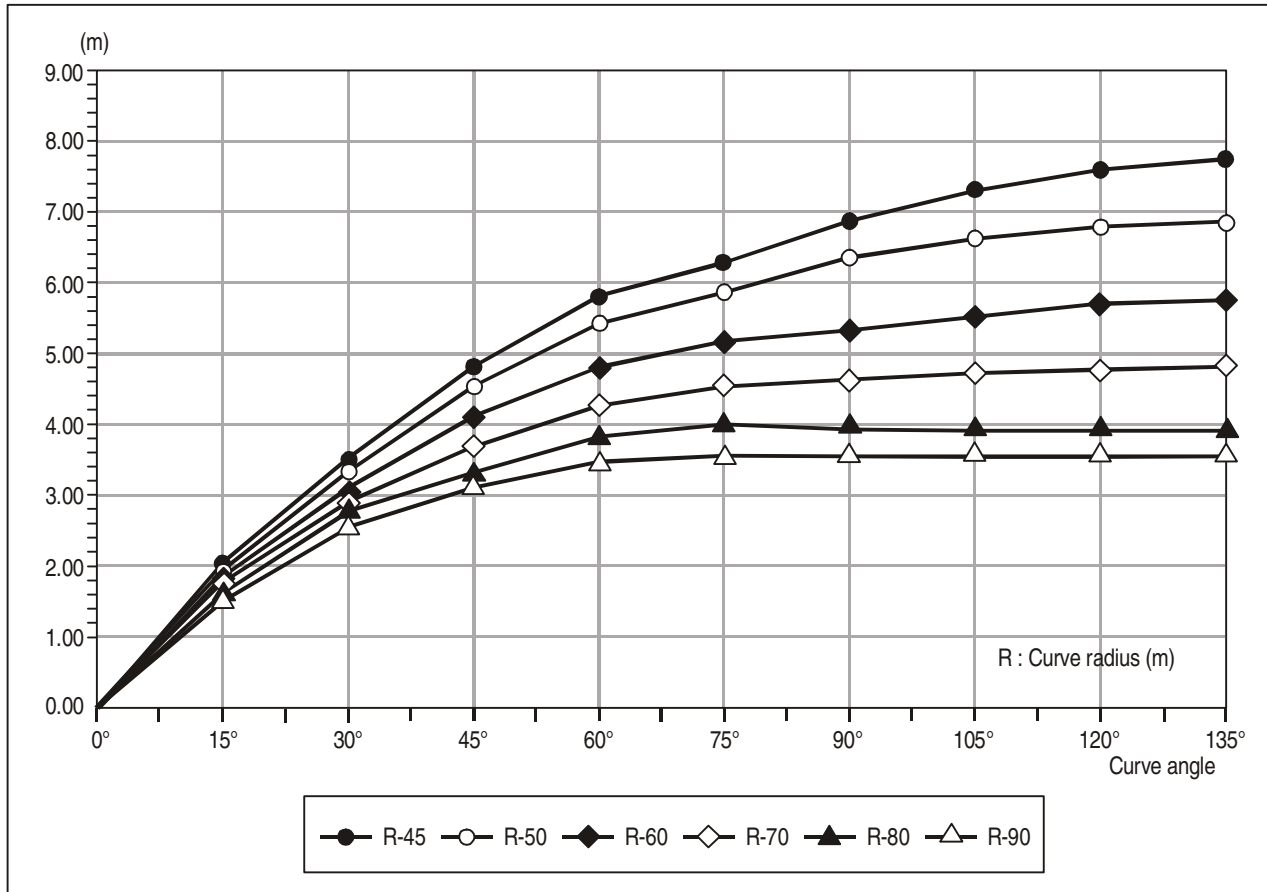

Figure 1-10. Maximum wing tip track-in as a function of curve radius 'R' and curve angle for B747-200

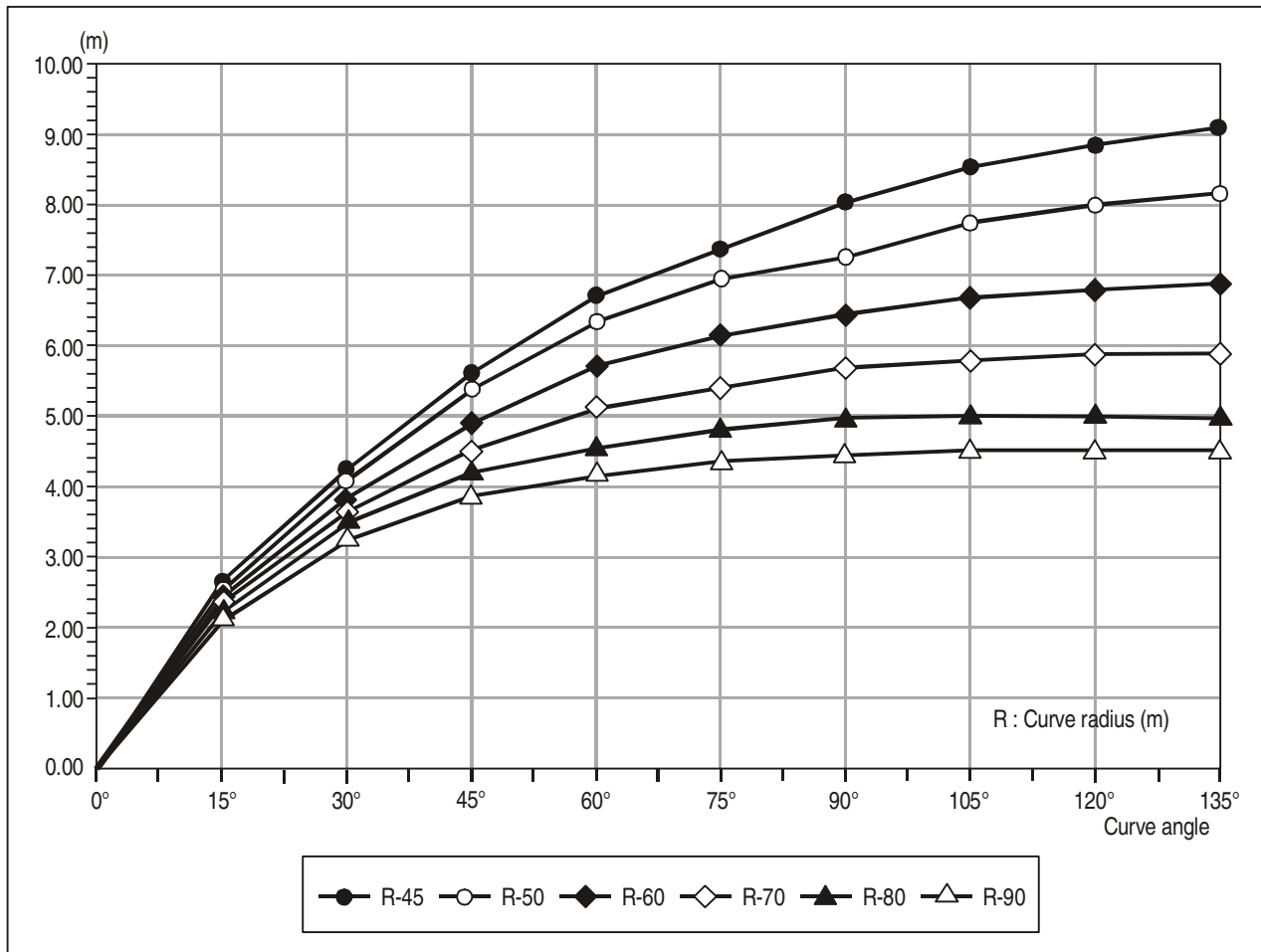

Figure 1-11. Maximum wing tip track-in as a function of curve radius 'R' and curve angle for A330-300 / A340-300

Taxiway/taxiway separation distances

1.2.50 The separation distances specified for parallel taxiways are intended to provide a safe wing tip clearance by accounting for the anticipated deviation of a manoeuvring aircraft from the taxiway centre line, in terms of:

- a) taxiing accuracy achieved in day-to-day operation; and
- b) inadvertent excursions/run-offs.

A study on whether lesser distances provide adequate safety margins in the operational environment of an existing aerodrome layout will require an assessment of the risk of collision which, owing to different levels involved, should be related to:

- a) straight parallel taxiways; and
- b) taxiway curves.

In either case, the risk of collision between two aircraft on parallel taxiways is determined primarily by the probability of an inadvertent major excursion by an aircraft from the taxiway centre line.

1.2.51 In contrast, taxiing accuracy per se is not considered to affect the collision risk to a critical extent in the case of straight parallel taxiways.

1.2.52 On taxiway curves, however, taxiing accuracy becomes a critical element in terms of collision risks for the various reasons outlined in 1.2.32 through 1.2.45. Accordingly, the trajectories of the wing tips of two large aircraft must be established.

1.2.53 When contemplating lesser separation distances, careful consideration must be given to the various factors affecting taxiing accuracy (1.2.32 through 1.2.45), in particular taxiway curves. In this regard, the maintenance of good surface friction characteristics under all environmental circumstances is considered a dominant prerequisite for minimizing:

- a) lateral deviations through proper nose-wheel steering and wheel-braking effectiveness; and
- b) risks of run-off.

Accordingly, the overall risk would be reduced essentially to the possibility of inadvertent major excursions resulting from unpredictable technical failures affecting the steering

capability of an aircraft (e.g. nose-wheel steering). The assessment of the overall risk would thus consist of:

- a) the probability of occurrence of a technical failure leading to a major excursion; and
- b) the exposure to collision risks subject to traffic density.

In the case of a) above, however, there is no indication that the probability rate of mechanical failures would be significant.

Taxiway/object separation distances

1.2.54 The risk considerations and the prerequisites related to reduced separation distances as outlined in 1.2.50 through 1.2.53 will similarly apply when assessing the adequacy of actual separation distances between the taxiway centre line and objects at an existing aerodrome. As far as the exposure to risks of collision is concerned, particular attention appears warranted with respect to:

- a) the nature of objects (fixed or mobile);
- b) their size (isolated or extended); and
- c) their location relative to straight portions of taxiways or taxiway curves.

1.2.55 It is reiterated that obstacles situated close to taxiway curves and adjacent areas will require particular examination. This includes not only consideration of wing tip clearances but also the possibility of impingement of jet wake on the object as a result of aircraft changing direction at an intersection.

Apron taxiway/object separation distances

1.2.56 In general, the apron is considered an area of high activity involving a changing pattern of obstacles of fixed/mobile and permanent or temporary nature in a variable operating environment. Accordingly, aircraft operating along an apron taxiway may be exposed to incomparably higher risks of collision as compared to aircraft taxiing on a standard taxiway, margins accounted for by the formula in terms of deviation and increment being the same. This is actually evidenced by the comparatively high rate of reported incidents occurring on aprons, which is a matter of continuing concern. There is, however, no indication of the incidents being related to basic inadequacies of the specified minimum separation distances.

1.2.57 Nevertheless, it may be reasonably assumed that at an aerodrome where lesser separation is provided, there is increased potential for incidents to occur unless a set of specific requirements relating to all critical elements involved in apron activities is fulfilled.

1.2.58 Risks of collision relate predominantly to mobile objects which may infringe upon clearance distances relative to taxiing aircraft. Accordingly, a basic requirement would be to segregate the operating area of an aircraft from the respective area intended to be used by mobile objects (e.g. servicing vehicles and equipment facilities). Specifically this would include:

- a) for the aircraft:
 - taxi guidelines (marking and lighting);
- b) for mobile objects:
 - apron safety lines (see Annex 14, Volume I, Chapter 5)
 - service road boundary lines
 - procedures and regulations to ensure discipline.

1.2.59 Concerning taxi guidance on aprons, it is of paramount importance, in order to minimize the risk of major excursions, that the pilot be provided with a conspicuous and unambiguous guideline which is visible continuously in all prevailing operating conditions. This guideline is crucial for pilots of large aircraft who, being unable to routinely observe the wing tip and having difficulty judging small clearances, must follow the designated guidelines as closely as practicable. While doing so, pilots will have to rely on safe taxiing at normal taxi speed.

1.2.60 To ensure accurate manoeuvring and prevent large deviations, when nose-wheel steering or braking effectiveness is marginal, the provision of good surface friction characteristics is important, especially when high cross-winds are encountered.

Aircraft stand taxi/line/object separation distances

1.2.61 The preceding apron-oriented risk aspects and functional requirements are equally valid for separation distances between aircraft stand taxi/line centre lines and

1.2.62 From an operational point of view, the separation distance as specified by the formula in terms of a reduced gear deviation allowance and safety buffer is rated as rather marginal relative to an operating environment where the exposure to collision risks is normally greatest and the accuracy of aircraft manoeuvring is most demanding. Reducing the specified values, therefore, should be considered as a last resort only, conditional to a study scrutinizing all risk aspects discussed in this section as applicable to the most unfavourable operating conditions representative of the aerodrome concerned. In conducting the study, consultation with the aircraft operator is essential to ascertain whether the operational aircraft parameters assumed in the study are realistic.

Taxiway dimensions, surface and shoulders

1.2.63 An aeronautical study should further examine the level of protection provided by existing physical layouts against run-offs from taxiway pavements. This relates primarily to the width of taxiways and associated wheel-to-edge clearances.

Width of taxiways. The specified wheel-to-edge clearance of 4.5 m for code letters E and F is considered a minimum. Accordingly, the width of taxiways should provide this clearance, in particular on curves and at intersections. As a minimum, the width of taxiways should be equal to the sum of the wheel-to-pavement edge clearance on both sides plus the maximum outer main gear span for the code letter.

Protection of engines against foreign object damage

1.2.64 The degree of damage caused to engines from ingesting foreign objects is substantial and, therefore, a matter of continuing concern. As new larger aeroplanes are equipped with more powerful engines, the problem is likely to be aggravated. Protection of the taxiway shoulders extending laterally at least to the outer engine is therefore needed. Similarly, it should be ascertained whether the type of surface of the shoulder is adequate to resist erosion from engine blast.

1.2.65 At airports subjected to snow and ice conditions, the problem caused by foreign object damage is particularly critical on the entire movement area. The extent to which snow/ice clearance is carried out will determine the risk level not only for foreign object damage but likewise for run-offs.

Notification

1.2.66 When recommended clearance distances are not provided at certain locations of the movement area at a particular airport, this should be appropriately identified in the Aerodrome Chart — ICAO (Annex 4, Chapter 13 refers) for operational evaluation by aircraft operators and pilots.

The effect of new larger aeroplanes on existing airports

1.2.67 To meet the needs of an ever changing aviation industry, succeeding generations of larger aeroplanes have been introduced. Experience gained through the introduction of these aeroplanes has taught airport planners that adequate planning in the initial design of an airport is vital. However, in spite of the best efforts of airport planners, a facility developed for the current generation of aeroplanes may not be adequate for succeeding generations. In order to minimize any impact on capacity, airports would need to be expanded and developed to accommodate such new larger aeroplanes.

1.2.68 With a view to complying with applicable specifications, airport planners and engineers have to explore all avenues while undertaking the rehabilitation of existing facilities. Often, after due consideration of all options, the physical limitations of the existing facilities may leave the airport operator with no choice but to implement operational restrictions.

Taxiway minimum separation distances

1.2.69 As stated in 1.2.46, the main principle governing runway/taxiway separation distances is that the wing tip of a taxiing aeroplane should not penetrate the strip of the associated runway. This principle is especially relevant when it is planned to operate new aircraft with greatly increased wingspans at existing airports which were not designed to accommodate such aircraft. Care must be taken to ensure that the increased wingspan of a new larger aircraft does not increase the risk of collision with another aircraft taxiing on a parallel taxiway if the larger aircraft inadvertently runs off a runway, and that ILS critical and sensitive areas are protected. Where the wingspan of an aeroplane on a taxiway penetrates the associated runway strip or the safety zone of a parallel runway, appropriate

operational restrictions, such as the taxiway not being used by an aeroplane of such large wingspan, will have to be considered. In most cases, to maintain aerodrome capacity, simultaneous operations of smaller aeroplanes that would not infringe upon the safety zones of the more demanding aeroplanes may be considered, after due study. For instance, at existing aerodromes with runway and taxiway separation distances complying with code letter E specifications, it may be permissible to operate a code letter E or smaller aeroplane on the existing parallel taxiway while a code letter F aeroplane is using the runway.

1.2.70 However, the minimum separation distance between a code letter E runway and parallel taxiway may not provide adequate length for a link taxiway, connecting the parallel taxiway and the runway, to permit safe taxiing of a code letter F aircraft behind an aircraft holding short of the runway at the holding position. To permit such operations, the parallel taxiway should be so located as to comply with the requirements of Annex 14, Volume I, Tables 3-1 and 3-2, considering the dimensions of the most demanding aeroplane in a given aerodrome code. For example, at a code E aerodrome, this separation would be equal to the sum of the distance of the runway holding position from the runway centre line, plus the overall length of the most demanding aeroplane, and the taxiway-to-object distance specified in column E of Table 1-1.

1.2.71 At issue is the need to provide adequate clearances on an existing airport in order to operate a new larger aircraft with the minimum risk possible. If the clearance distances given Annex 14, Volume I cannot be met, then an aeronautical study should be conducted to ensure operational safety and to ascertain what, if any, operational restrictions must be implemented to maintain safety (see Figure 1-12).

1.2.72 In order to minimize such restrictions, when a new facility is planned for addition to the existing airport infrastructure, it would be prudent to apply the basic clearance distance concept adopted in the development of the specifications found in Annex 14, Volume I. An example of the application of this concept would be:

An airport with an aerodrome reference code E is planning to develop a new link taxiway for code F operations, adjacent to an existing code E taxiway. What should be the separation between them?

If both taxiways are to be used for simultaneous code F aeroplane operations (provided all other relevant

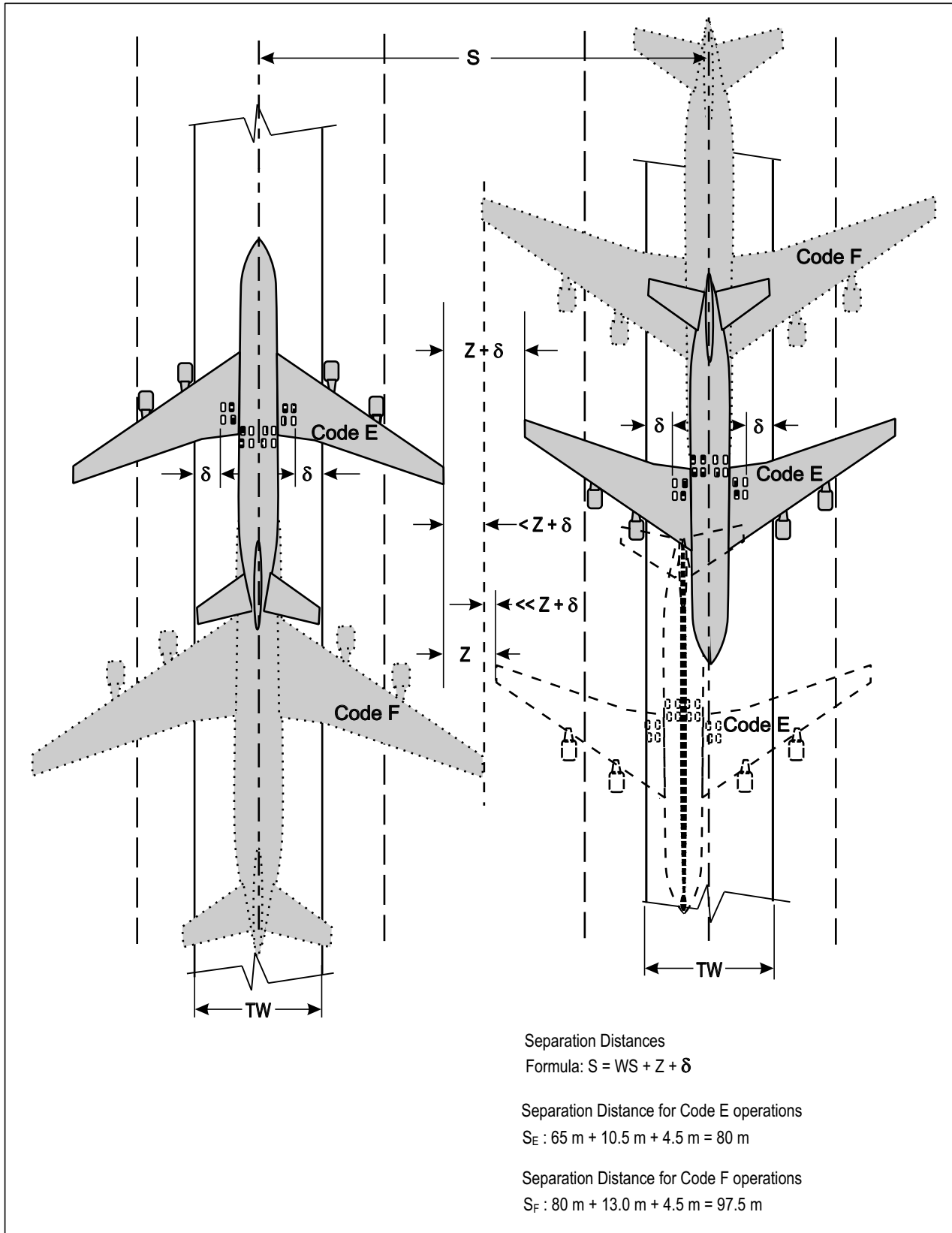

Figure 1-12. Taxiway to taxiway separation distances

requirements are satisfactorily met) then the minimum separation distance should be that specified for code F in Annex 14, Volume I, Table 3-1, column 10.

If the existing taxiway is to be used by code E aircraft only, then the new code F taxiway may be located as follows:

Minimum separation distance: $(\frac{1}{2} WS_E + \frac{1}{2} WS_F) + C + Z_F$ where WS is the wing span, C is the applicable wheel-to-pavement edge clearance (4.5 m in this case) and Z_F is the safety margin (13 m) for Code F – the most demanding code.

In this case, airport capacity may be slightly reduced should there be a need for two code F aeroplanes to use these taxiways simultaneously since the existing taxiway is not in accordance with code F specifications. Where such a philosophy is implemented with respect to other facilities, a similar approach may be adopted, provided the values of the wheel-to-taxiway edge clearance and wing tip clearance used are those for the higher code letter.

Apron size and capacity, stand clearances and taxiing on aprons

1.2.73 The existing aprons on most of today's airports were not designed with Code F aeroplanes in mind. The 80 m wingspan and the potential for greater fuselage length of Code F aeroplanes will have a direct bearing on how many of these aeroplanes can be accommodated on existing aprons and where they can be accommodated. For Code F aeroplanes, existing stands should provide clearances of 7.5 m as specified in Annex 14, Volume I. Existing stands that are unable to provide such clearances will need to be modified. Again, operational restrictions may have to be developed to ensure safe operations.

1.2.74 Adequate clearances behind parked or holding aeroplanes should also be provided. This issue is impacted not only by the wingspan of the taxiing aeroplanes but also the fuselage length of the parked aeroplanes. While the 80 m wingspan limit of Code F is a defining criterion, the fuselage length of these aeroplanes will also have a direct bearing on their effect on other taxiing aeroplanes. Therefore, while aeroplanes with a wingspan of almost 80 m may be faced with operational restrictions due to their wingspans, it may be also necessary to implement operational restrictions in those cases where the increased fuselage length of code F aircraft may cause reduced clearances with other taxiing aircraft.

1.3 RAPID EXIT TAXIWAYS (RETS)

General

1.3.1 A rapid exit taxiway is a taxiway connected to a runway at an acute angle and designed to allow landing aeroplanes to turn off at higher speeds than those achieved on other exit taxiways, thereby minimizing runway occupancy time.

1.3.2 A decision to design and construct a rapid exit taxiway is based upon analyses of existing and contemplated traffic. The main purpose of these taxiways is to minimize aircraft runway occupancy and thus increase aerodrome capacity. When the design peak hour traffic density is approximately less than 25 operations (landings and take-offs), the right angle exit taxiway may suffice. The construction of this right angle exit taxiway is less expensive, and when properly located along the runway, achieves an efficient flow of traffic.

1.3.3 The establishment of a single worldwide standard for the design of rapid exit taxiways has many obvious advantages. Pilots become familiar with the configuration and can expect the same results when landing at any aerodrome with these facilities. Accordingly, design parameters have been established in Annex 14, Volume I for a grouping of exit taxiways associated with a runway whose code number is 1 or 2 and another grouping for code number 3 or 4. Since the introduction of rapid exit taxiways, additional field tests and studies have been conducted to determine taxiway utilization, exit taxiway location and design, and runway occupancy time. Evaluation of such material has led to the development of exit taxiway location and design criteria based on specified aircraft populations moving at relatively high speeds.

1.3.4 There is some difference of opinion with respect to the speed at which pilots negotiate rapid exit taxiways. While it has been inferred from some studies that these taxiways are normally used at a speed not higher than 46 km/h (25 kt) and even in some cases at lower speeds when poor braking action or strong cross-winds are encountered, measurements at other aerodromes have shown that they are being used at speeds of over 92 km/h (49 kt) under dry conditions. For safety reasons 93 km/h (50 kt) has been taken as the reference for determining curve radii and adjacent straight portions for rapid exit taxiways where the code number is 3 or 4. For computing the optimum exit locations along the runway, however, the planner will choose a lower speed. In any case, the optimum utilization of rapid exits requires pilot cooperation.

Instruction on the design of, and benefits to be obtained from use of, these taxiways may increase their use.

Location and number of exit taxiways

Planning criteria

1.3.5 The following basic planning criteria should be considered when planning rapid exit taxiways to ensure that, wherever possible, standard design methods and configurations are used:

- a) For runways exclusively intended for landings, a rapid exit taxiway should be provided only if dictated by the need for reduced runway occupancy times consistent with minimum inter-arrival spacings;
- b) For runways where alternating landings and departures are conducted, time separation between the landing aircraft and the following departing aircraft is the main factor limiting runway capacity;
- c) As different types of aircraft require different locations for rapid exit taxiways, the expected aircraft fleet mix will be an essential criterion;
- d) The threshold speed, braking ability and operational turn-off speed (V_{ex}) of the aircraft will determine the location of the exits.

1.3.6 The location of exit taxiways in relation to aircraft operational characteristics is determined by the deceleration rate of the aircraft after crossing the threshold. To determine the distance from the threshold, the following basic conditions should be taken into account:

- a) threshold speed; and
- b) initial exit speed or turn-off speed at the point of tangency of the central (exit) curve (point A, Figures 1-13 and 1-14).

Design, location and number of rapid exit taxiways

1.3.7 Determining the optimum location and required number of rapid exit taxiways to suit a particular group of aeroplanes is recognized as a comparatively complex task owing to the many criteria involved. Although most of the operational parameters are specific to the type of aircraft

with respect to the landing manoeuvre and subsequent braked deceleration, there are some criteria which are reasonably independent of the type of aircraft.

1.3.8 Accordingly, a methodology, known as the Three Segment Method, was developed which permits the determination of the typical segmental distance requirements from the landing threshold to the turn-off point based on the operating practices of individual aircraft and the effect of the specific parameters involved. The methodology is based on analytical considerations supplemented by empirical assumptions, as described below.

1.3.9 For the purpose of exit taxiway design, the aircraft are assumed to cross the threshold at an average of 1.3 times the stall speed in the landing configuration at maximum certificated landing mass with an average gross landing mass of about 85 per cent of the maximum. Further, aircraft can be grouped on the basis of their threshold speed at sea level as follows:

Group A — less than 169 km/h (91 kt)

Group B — between 169 km/h (91 kt) and 222 km/h (120 kt)

Group C — between 224 km/h (121 kt) and 259 km/h (140 kt)

Group D — between 261 km/h (141 kt) and 306 km/h (165 kt), although the maximum threshold crossing speed of aircraft currently in production is 282 km/h (152 kt).

1.3.10 An analysis of some aircraft indicates that they may be placed in the groups as follows:

Group A

DC3
DHC6
DHC7

Group B

Avro RJ 100
DC6
DC7
Fokker F27
Fokker F28
HS146
HS748
IL76

Group C

- A300, A310, A320, A330
- B707-320
- B727
- B737
- B747-SP
- B757
- B767
- DC8 (all versions except 61 and 63)
- DC9
- MD80
- MD90
- DC10-10
- L1011-200

- MD-11
- IL62
- IL86
- IL96
- L1011-500
- TU154

1.3.11 The number of exit taxiways will depend on the types of aircraft and number of each type that operate during the peak period. For example, at a very large aerodrome, most aircraft will likely be in groups C or D. If so, only two exits may be required. On the other hand, an aerodrome having a balanced mixture of all four groups of aircraft may require four exits.

Group D

- A340
- B747
- B777
- DC8 (61 and 63)
- DC10-30/40

1.3.12 Using the Three Segment Method, the total distance required from the landing threshold to the point of turn-off from the runway centre line can be determined according to the method illustrated in Figure 1-15.

The total distance S is the sum of three distinct segments which are computed separately.

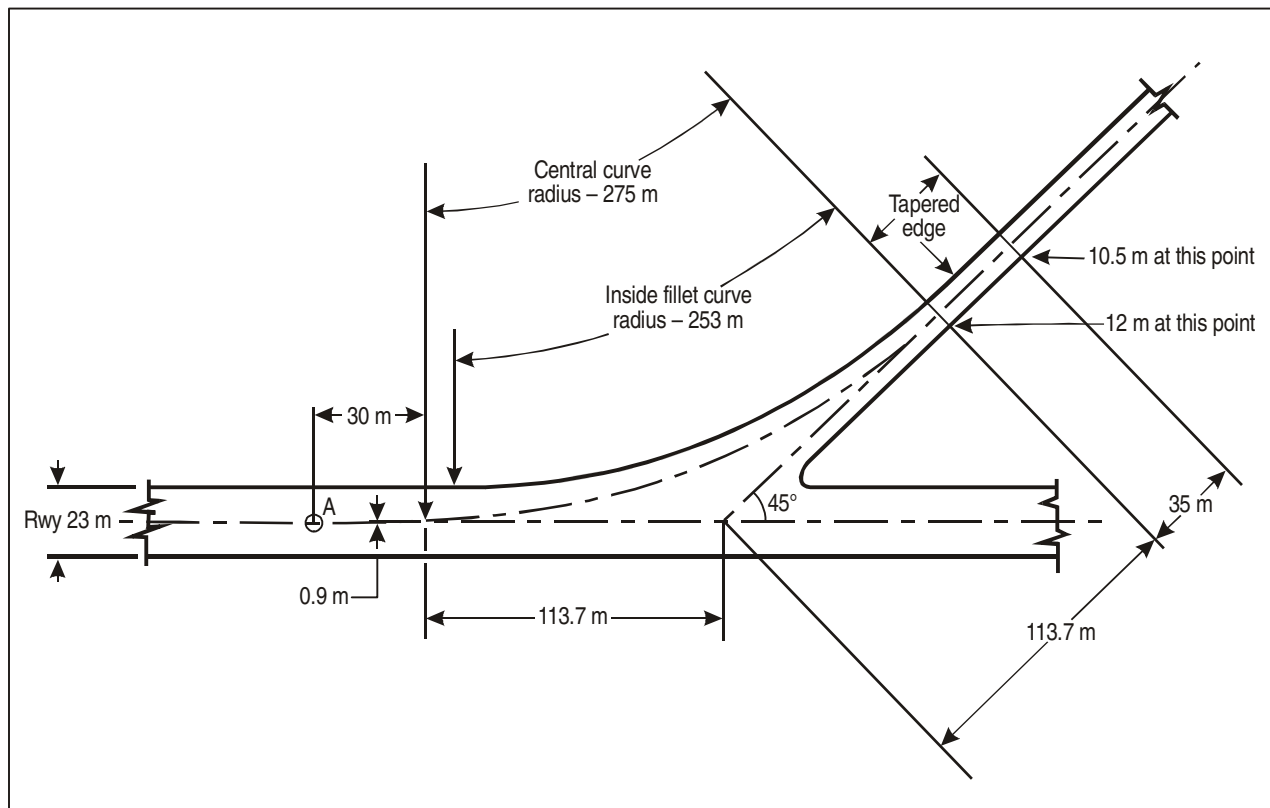

Figure 1-13. Design for rapid exit taxiways (code number 1 or 2)

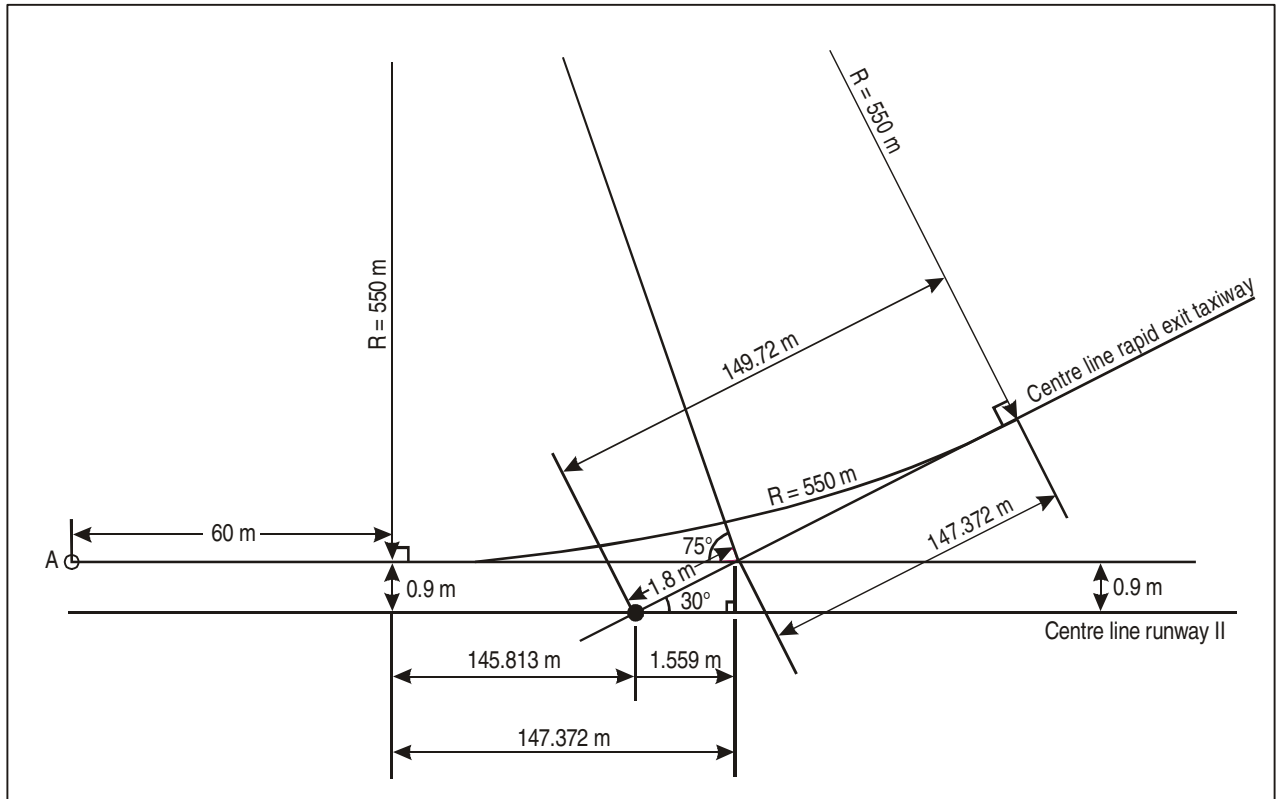

Figure 1-14. Design for rapid exit taxiways (code number 3 or 4)

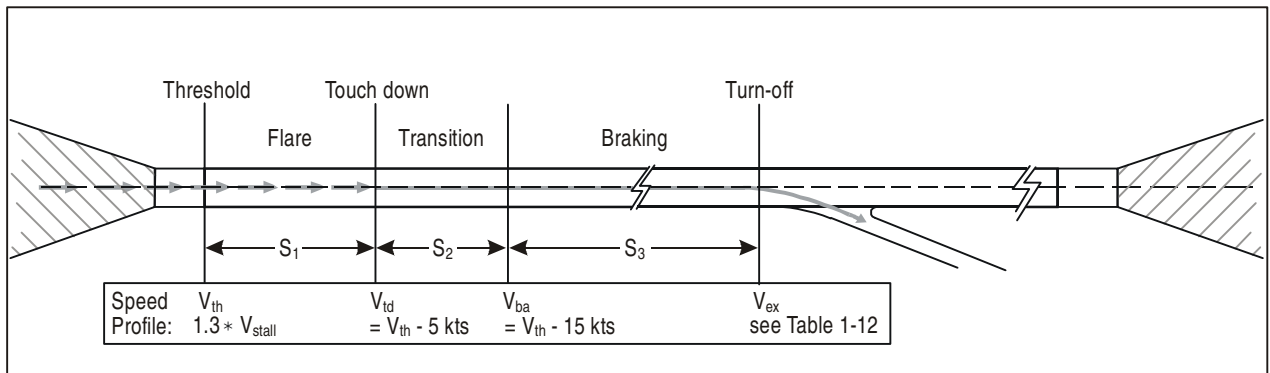

Figure 1-15. Three segment method

Segment 1: Distance required from landing threshold to main gear touchdown (S_1).

Segment 2: Distance required for transition from main gear touchdown to establish stabilized braking configuration (S_2).

Segment 3: Distance required for deceleration in a normal braking mode to a nominal turnoff speed (S_3).

Speed profile:

V_{th} Threshold speed based on 1.3 times the stall speed of assumed landing mass equal to 85 per cent of maximum landing mass. Speed is corrected for elevation and airport reference temperature.

V_{td} Assumed as $V_{th} - 5$ kts (conservative). Speed decay considered representative for most types of aircraft.

V_{ba} Assumed brake application speed.

$V_{th} - 15$ kts (wheel brakes and/or reverse thrust application).

V_{ex} Nominal turn-off speed:
Code number 3 or 4: 30 kts
Code number 1 or 2: 15 kts

for standard rapid exit taxiways according to Figures 1-13 and 1-14.

For other types of exit taxiways see Table 1-11 and Figure 1-16 for turn-off speed.

Distances [in m]:

S_1 Empirically derived firm distance to mean touchdown point, corrected for downhill slope and tailwind component where applicable.

Aircraft category C and D: $S_1 = 450$ m
Correction for slope: + 50 m / - 0.25%
Correction for tailwind: + 50 m / + 5 kts

Aircraft category A and B: $S_1 = 250$ m
Correction for slope: + 30 m / - 0.25%
Correction for tailwind: + 30 m / + 5 kts

S_2 The transition distance is calculated for an assumed transition time (empirical) $\Delta t = 10$ seconds at an average ground speed of:

$$S_2 = 10 \times V_{av} \quad [V_{av} \text{ in m/s}], \text{ or}$$

$$S_2 = 5 \times (V_{th} - 10) \quad [V_{th} \text{ in kts}]$$

S_3 The braking distance is determined based on an assumed deceleration rate 'a' according to the following equation:

$$S_3 = \frac{V_{ba}^2 - V_{ex}^2}{2a} \quad [V \text{ in m/s}, a \text{ in m/s}^2], \text{ or}$$

$$S_3 = \frac{(V_{th} - 15)^2 - V_{ex}^2}{8a} \quad [V \text{ in kts}, a \text{ in m/s}^2]$$

A deceleration rate of $a = 1.5 \text{ m/s}^2$ is considered a realistic operational value for braking on wet runway surfaces.

1.3.13 The final selection of the most practical rapid exit taxiway location(s) must be considered in the overall planning requirements, taking into account other factors such as:

- location of the terminal/apron area
- location of other runways and their exits
- optimization of traffic flow within the taxiway system with respect to traffic control procedures
- avoidance of unnecessary taxi detours, etc.

Furthermore, there may be a need to provide additional exit taxiways — especially at long runways — after the main rapid exit(s) depending upon local conditions and requirements. These additional taxiways may or may not be rapid exit taxiways. Intervals of approximately 450 m are recommended up to within 600 m of the end of the runway.

1.3.14 Some aerodromes have heavy activity of aircraft in code number 1 or 2. When possible, it may be desirable to accommodate these aircraft on an exclusive runway with a rapid exit taxiway. At those aerodromes where these aircraft use the same runway as commercial air transport operations, it may be advisable to include a rapid exit taxiway to expedite ground movement of the small aircraft. In either case, it is recommended that this exit taxiway be located at 450 m to 600 m from the threshold.

1.3.15 As a result of Recommendation 3/5 framed by the Aerodromes, Air Routes and Ground Aids Divisional Meeting (1981), ICAO in 1982 compiled data on actual rapid exit taxiway usage. The data, which were collected from 72 airports and represented operations on 229 runway

Table 1-11. Aircraft speed versus the radius of a rapid exit taxiway

Radii R [m]:	V_{des} [kts]:	V_{op} [kts]:
40	14	13
60	17	16
120	24	22
160	28	24
240	34	27
375	43	30
550	52	33

Based on the design exit speed V_{des} complying with a lateral acceleration of 0.133 g, the operational turn-off speed V_{op} is determined empirically to serve as the criterion for the optimal location of the exit.

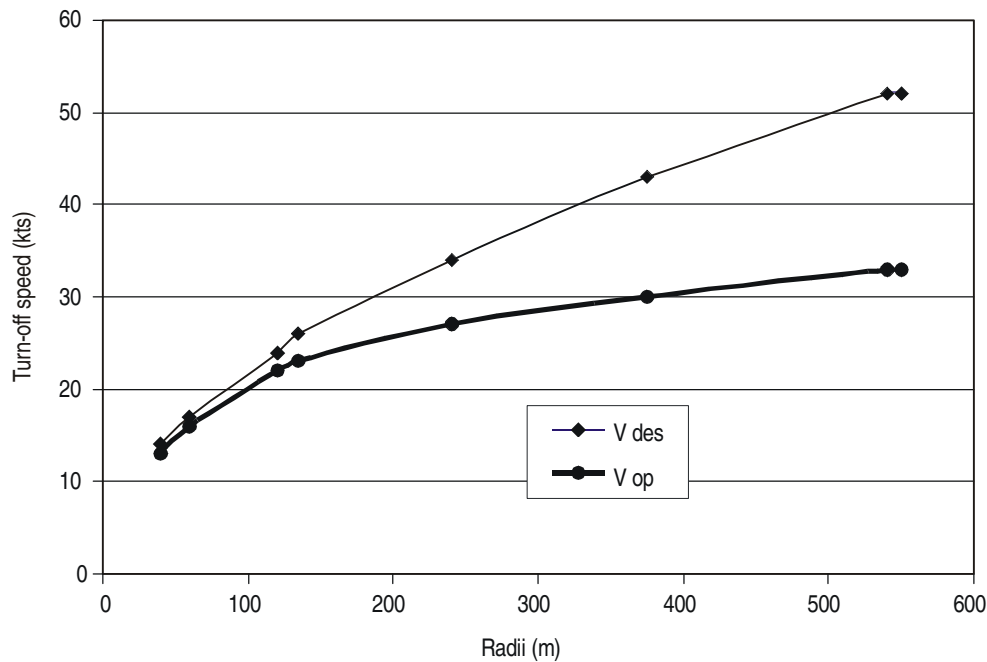

Figure 1-16. Aircraft speed versus the radius of a rapid exit taxiway

headings, provided information on the type of exit taxiway, distances from threshold to exits, exit angle and taxiway usage for each runway heading. During the analysis it was assumed that the sample size of the surveyed data was equal for each runway heading. Another assumption was that whenever an aircraft exited through an exit taxiway located at an angle larger than 45°, the aircraft could have exited through a rapid exit taxiway, had there been a rapid

exit taxiway on that location (except the runway end). The accumulated rapid exit usage versus distance from thresholds is tabulated in Table 1-12. This means that had there been a rapid exit taxiway located at a distance of 2 200 m from thresholds, 95 per cent of aircraft in group A could have exited through that exit taxiway. Similarly, rapid exit taxiways located at 2 300 m, 2 670 m and 2 950 m from thresholds could have been utilized by 95 per cent of

Table 1-12. Accumulated rapid exit usage by distance from threshold (metres)

Aircraft category	50%	60%	70%	80%	90%	95%	100%
A	1 170	1 320	1 440	1 600	1 950	2 200	2 900
B	1 370	1 480	1 590	1 770	2 070	2 300	3 000
C	1 740	1 850	1 970	2 150	2 340	2 670	3 100
D	2 040	2 190	2 290	2 480	2 750	2 950	4 000

aircraft in groups B, C and D, respectively. The table shows the distances as corrected by using the correction factors suggested in the study carried out by the Secretariat and presented to the AGA/81 Meeting, namely, 3 per cent were 300 m of altitude and 1 per cent per 5.6°C above 15°C. Current data on actual rapid exit taxiway usage at airports are yet to be compiled.

Geometric design

1.3.16 Figures 1-13 and 1-14 present some typical designs for rapid exit taxiways in accordance with the specifications given in Annex 14, Volume I. For runways of code number 3 or 4, the taxiway centre line marking begins at least 60 m from the point of tangency of the central (exit) curve and is offset 0.9 m to facilitate pilot recognition of the beginning of the curve. For runways of code number 1 or 2, the taxiway centre line marking begins at least 30 m from the point of tangency of the central (exit) curve.

1.3.17 A rapid exit taxiway should be designed with a radius of turn-off curve of at least:

550 m where the code number is 3 or 4, and
275 m where the code number is 1 or 2;

to enable exit speeds under wet conditions of:

93 km/h (50 kt) where the code number is 3 or 4, and
65 km/h (35 kt) where the code number is 1 or 2.

1.3.18 The radius of the fillet on the inside of the curve at a rapid exit taxiway should be sufficient to provide a widened taxiway throat in order to facilitate recognition of the entrance and turn-off onto the taxiway.

1.3.19 A rapid exit taxiway should include a straight distance after the turn-off curve sufficient for an exiting

aircraft to come to a full stop clear of any intersecting taxiway and should not be less than the following when the intersection angle is 30°:

Code number	Code number
1 or 2	3 or 4
35 m	75 m

The above distances are based on deceleration rates of 0.76 m/sec² along the turn-off curve and 1.52 m/sec² along the straight section.

1.3.20 The intersection angle of a rapid exit taxiway with the runway should not be greater than 45° nor less than 25° and preferably should be 30°.

1.4 TAXIWAYS ON BRIDGES

General

1.4.1 The layout of an aerodrome, its dimensions and/or the extension of its runway/taxiway system may require taxiways to bridge over surface transport modes (roads, railways, canals) or open water (rivers, sea bays). Taxiway bridges should be designed so as not to impose any difficulties for taxiing aircraft and to permit easy access to emergency vehicles responding to an emergency involving an aircraft on the bridge. Strength, dimensions, grades and clearances should allow unconstrained aircraft operations day and night as well as under varying seasonal conditions, i.e. heavy rain, periods of snow and ice coverage, low visibility or gusty winds. The requirements of taxiway maintenance, cleaning and snow removal, as well as emergency evacuation of the aircraft occupants, should be taken into account when bridges are being designed.

Siting

1.4.2 For operational and economic reasons the number of bridging structures required and problems related therewith can be minimized by applying the following guidelines:

- a) if possible, the surface modes should be routed so that the least number of runways or taxiways will be affected;
- b) the surface modes should be concentrated so that preferably all can be bridged with a single structure;
- c) a bridge should be located on a straight portion of a taxiway with a straight portion provided on both ends of the bridge to facilitate the alignment of the aeroplanes approaching the bridge;
- d) rapid exit taxiways should not be located on a bridge; and
- e) bridge locations that could have an adverse effect upon the instrument landing system, the approach lighting or runway/taxiway lighting systems should be avoided.

Dimensions

1.4.3 The design of the bridge structure is determined by its purpose and the specifications relevant to the transport mode that it will serve. Aeronautical requirements should be met with respect to width and gradings, etc., of the taxiway.

1.4.4 The bridge width measured perpendicularly to the taxiway centre line shall not be less than the width of the graded portion of the strip provided for that taxiway, unless a proven method of lateral restraint is provided which shall not be hazardous for aeroplanes for which the taxiway is intended. Therefore, minimum width requirements will normally be:

- | | |
|------|---------------------------------|
| 22 m | where the code letter is A |
| 25 m | where the code letter is B or C |
| 38 m | where the code letter is D |
| 44 m | where the code letter is E |
| 60 m | where the code letter is F |

with the taxiway in the centre of the strip. In the exceptional cases when a curved taxiway has to be located on the

bridge, extra width should be provided to compensate for the unsymmetrical movement of the aircraft by track-in of the main gear.

1.4.5 If the type of aircraft using the aerodrome is not clearly defined or if the aerodrome is limited by other physical characteristics, the width of the bridge to be designed should be related to a higher code letter from the very beginning. This will prevent the aerodrome operator from taking very costly corrective action once a larger aircraft starts to operate on that aerodrome and has to use the taxiway bridge.

1.4.6 The taxiway width on the bridge should be at least as wide as off the bridge. Unlike the construction of other parts of the taxiway system, the strip on the bridge will normally have a paved surface and serve as a fully bearing shoulder. Additionally, the paved strip on the bridge facilitates maintenance and, where necessary, snow clearing work. Furthermore, the paved surface strip provides access to the bridge for rescue and fire fighting vehicles as well as other emergency vehicles.

1.4.7 The efficiency of ground movement operations will be enhanced if aircraft are able to approach and depart from bridges on straight portions of the taxiway. These will enable aircraft to align themselves with the main undercarriage astride the taxiway centre line before crossing the taxiway bridge. The length of the straight section should be at least twice the wheel base (distance from the nose gear to the geometric centre of the main gear) of the most demanding aircraft and not less than

- | | |
|------|---------------------------|
| 15 m | for code letter A |
| 20 m | for code letter B |
| 50 m | for code letter C, D or E |
| 70 m | for code letter F. |

It should be noted that possible future aircraft may have a wheel base of 35 m or more indicating a requirement for a straight distance of at least 70 m.

Gradients

1.4.8 For drainage purposes, taxiway bridges are generally designed with normal taxiway transverse slopes. If, for other reasons, a slope less than 1.5 per cent has been selected, consideration should be given to the provision of sufficient drainage capability on the taxiway bridge.

1.4.9 Ideally, the bridge should be level with the adjacent aerodrome terrain. If, for other technical reasons, the

top of the bridge must be higher than the surrounding aerodrome terrain, the adjoining taxiway sections should be designed with slopes which do not exceed the longitudinal gradients specified in Table 1-1.

Bearing strength

1.4.10 A taxiway bridge should be designed to support the static and dynamic loads imposed by the most demanding aircraft expected to use the aerodrome. Future trends of aircraft mass development should be taken into account in specifying the “most demanding aircraft”. Information on future trends is regularly issued by the manufacturers’ associations. Incorporation of future requirements may help to avoid costly redesign of bridges due to progress in technology and/or increasing transport demand.

1.4.11 The strength of the bridge should normally be sufficient over the entire width of the graded area of taxiway strip to withstand the traffic of the aeroplanes the taxiway is intended to serve. Minimum width requirements are specified in 1.4.4. Parts of the same bridge that have been added to serve vehicular traffic only may have lesser strength than those intended for aircraft traffic.

Lateral restraint

1.4.12 When the full load-bearing width provided is less than that of the graded area of the taxiway strip, a proven method of lateral restraint should be provided that shall not be hazardous to aeroplanes for which the taxiway is intended. The lateral restraint system should be provided at the edges of the full load-bearing portion of the strip to prevent the aircraft from falling off the bridge or entering areas of reduced bearing strength. Lateral restraint devices should generally be considered as additional safety measures rather than a means of reducing the full load-bearing width of the taxiway bridge.

1.4.13 Information collected from States indicates that lateral restraint devices are normally provided on a taxiway bridge, irrespective of the width of the full load-bearing area. The lateral restraint device generally consists of a concrete curb which may serve as a barrier. Two examples of concrete curbs commonly used are shown in Figure 1-17. The recommended minimum distance for the location of the lateral restraint device varies among States, but a range between 9 and 27 m from the taxiway centre line was reported. However, factors mentioned in 1.4.6 should be kept in view when considering the location of lateral restraints. The curb is generally from 20 to 60 cm

high, the lowest type of curb being used when the width of the graded area is significantly greater than the width of the taxiway strip. Taxiway bridges have been in service for varying periods of time, some of them for over twenty years, and no occurrences of aircraft running off taxiway bridges have been reported.

1.4.14 It may be desirable to provide a second lateral restraint device. This device may consist of a concrete curb or a safety guard rail which is not designed to prevent aircraft running off the taxiway but rather as a safety measure for maintenance personnel and vehicles using the bridge.

Blast protection

1.4.15 Where the taxiway passes over another transport mode, some kind of protection against aircraft engine blast may need to be provided. This can be accomplished by light cover construction of perforated material (bars or grid-type elements) capable of braking the initial jet blast to uncritical velocities of the order of 56 km/h. Contrary to closed covers, an open construction does not cause any drainage and loading capacity problems.

1.4.16 The overall width of the bridge and protected area should be equal to or exceed the blast pattern of the aircraft using the taxiway. This may be determined by reference to the manufacturers’ literature on the aircraft concerned.

1.5 FILLETS

General

1.5.1 Annex 14, Volume I, recommends minimum clearance distances between the outer main wheels of the aircraft which the taxiway is intended to serve and the edge of the taxiway when the cockpit of the aircraft remains over the taxiway centre line markings. These clearance distances are shown in Table 1-1. To meet these requirements when an aircraft is negotiating a turn, it may be necessary to provide additional pavement on taxiway curves and at taxiway junctions and intersections. It is to be noted that in the case of a taxiway curve the extra taxiway area provided to meet the recommended clearance distance requirement is part of the taxiway and therefore the term “extra taxiway width” is used rather than “fillet”. In the case of a junction or intersection of a taxiway with a runway, apron or another taxiway, however, the term “fillet” is considered to be the

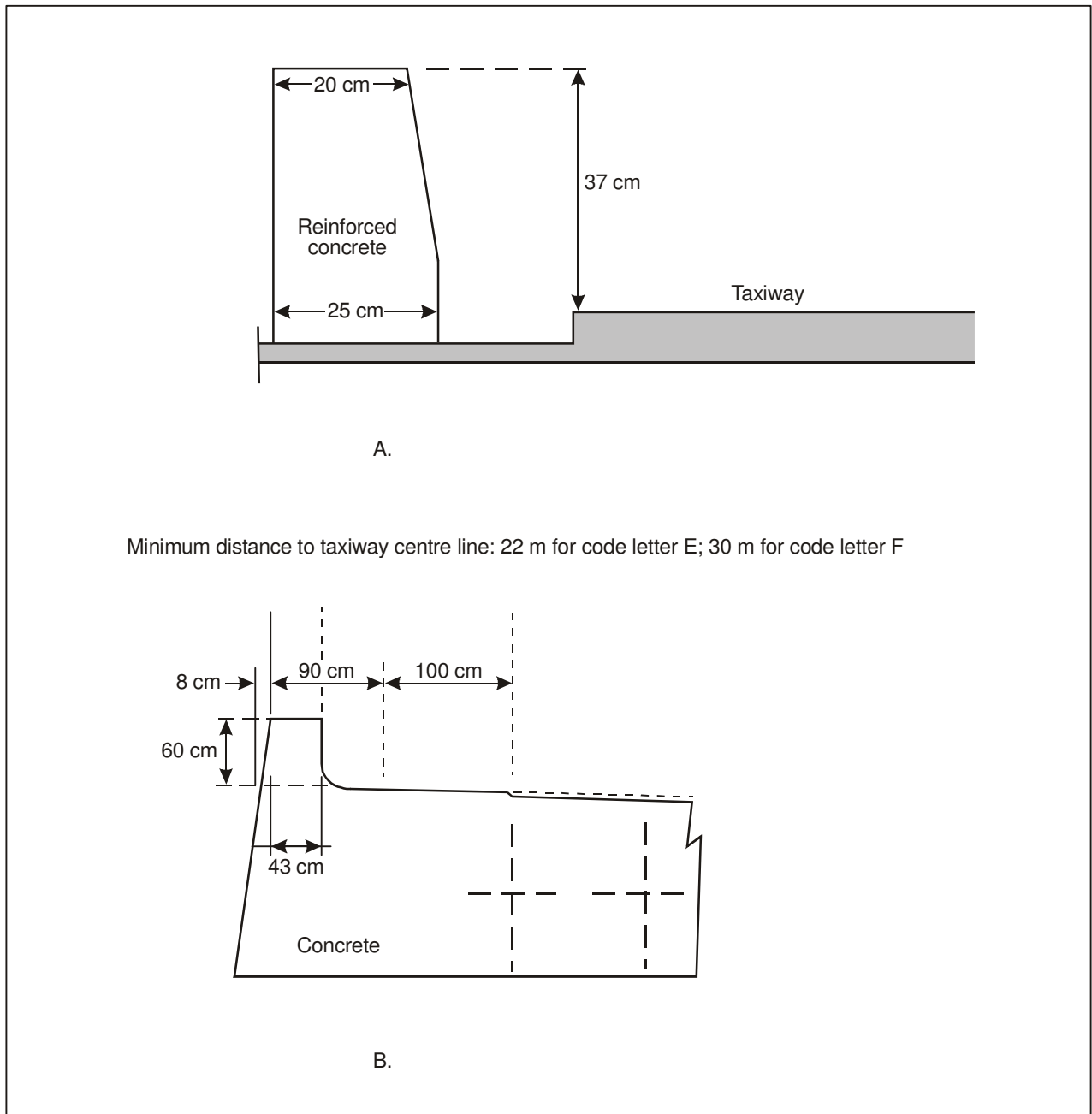

Figure 1-17. Examples of concrete curbs

appropriate term. In both cases (the extra taxiway width as well as the fillet), the strength of the extra paved surface to be provided should be the same as that of the taxiway. The following material presents concise information on fillet design.

Methods for manoeuvring aircraft on taxiway intersections

1.5.2 Specifications in Annex 14, Volume I concerning taxiway design as well as relevant visual aids specifications are based upon the concept that the cockpit of the aircraft remains over the taxiway centre line. Another method for manoeuvring aircraft on taxiway intersections is based upon offsetting the guideline. Three different ways to ensure compliance with the required clearance distances in Table 1-1 are:

- a) by using the taxiway centre line as the aircraft guidelines and providing a fillet;
- b) by offsetting the guidelines outwards;
- c) by a combination of offset guideline and fillet.

1.5.3 Methods b) and c) would appear to be the more economical solutions but the advantages are not as great as they seem. To obtain the maximum advantage there would have to be a separate guideline for each aircraft type and for use in both directions. Such a multiplicity of lines is impractical particularly when the taxiway is intended to be used at night or during poor visibility conditions, and it would thus be necessary to provide a compromise offset guideline that could be used by all aircraft.

1.6 TAXIWAY SHOULDERS AND STRIPS

General

1.6.1 A shoulder is an area adjacent to the edge of a full strength paved surface so prepared as to provide a transition between the full strength pavement and the adjacent surface. The main purpose of the provision of a taxiway shoulder is: to prevent jet engines that overhang the edge of a taxiway from ingesting stones or other objects that might damage the engine; to prevent erosion of the area adjacent to the taxiway; and to provide a surface for the occasional

passage of aircraft wheels. A shoulder should be capable of withstanding the wheel loading of the heaviest airport emergency vehicle. A taxiway strip is an area, including a taxiway, intended to protect an aircraft operating on the taxiway and to reduce the risk of damage to an aircraft accidentally running off the taxiway.

1.6.2 The widths to be provided for taxiway shoulders and strips are given in Table 1-1. It may be noted that shoulders 10.5 m wide for code letter E and 17.5 m wide for code letter F on both sides of the taxiway are considered to be suitable. These taxiway shoulder width requirements are based on the most critical aircraft operating in these categories, at this time. On existing airports, it is desirable to protect a wider area should operations by new larger aircraft, such as the Airbus A380 be planned, as the possibility of potential foreign object damage and the effect of exhaust blast on the taxiway shoulder during break away will be higher than those resulting from Boeing 747-400 operations. With respect to a taxiway where the code letter is E, a shoulder 10.5 m wide on both sides is considered to be suitable, assuming that the distance between the outboard engines of the critical aircraft normally using that taxiway will not exceed the outboard engine span of the B747-400.

1.6.3 The surface of the shoulder that abuts the taxiway should be flush with the surface of the taxiway while the surface of the strip should be flush with the edge of the taxiway or shoulder, if provided. For code letter C, D, E or F, the graded portion of the taxiway strip should not rise more than 2.5 per cent or slope down at a gradient exceeding 5 per cent. The respective slopes for code letter A or B are 3 per cent and 5 per cent. The upward slope is measured with reference to the transverse slope of the adjacent taxiway surface and the downward slope is measured with reference to the horizontal. There should, furthermore, be no holes or ditches tolerated within the graded portion of the taxiway strip. The taxiway strip should provide an area clear of objects which may endanger taxiing aeroplanes. Consideration will have to be given to the location and design of drains on a taxiway strip to prevent damage to an aircraft accidentally running off a taxiway. Suitably designed drain covers may be required.

1.6.4 No obstacles should be allowed on either side of a taxiway within the distance shown in Table 1-1. However, signs and any other objects which, because of their functions, must be maintained within the taxiway strip in order to meet air navigation requirements may remain but they should be frangible and sited in such a manner as to reduce to a minimum the hazard to an aircraft striking them. Such objects should be sited so that they cannot be struck by propellers, engine pods and wings of aircraft using the taxiway.

As a guide they should be so sited that there is nothing higher than 0.30 m above taxiway edge level within the taxiway strip.

Treatment

1.6.5 Taxiway shoulders and graded portions of strips provide an obstacle-free area intended to minimize the probability of damage to an aircraft using these areas accidentally or in an emergency. These areas should thus be prepared or constructed so as to reduce the risk of damage to an aircraft running off the taxiway and be capable of supporting access by rescue and fire fighting vehicles and other ground vehicles, as appropriate, over its entire area. When a taxiway is intended to be used by turbine-engined aircraft, the jet engines may overhang the edge of the taxiway while the aircraft is taxiing and may then ingest stones or foreign objects from the shoulders. Further, blast from the engines may impinge on the surface adjacent to the taxiway and may dislodge material with consequent hazard to personnel, aircraft and facilities. Certain precautions must therefore be taken to reduce these possibilities. The type of surface of the taxiway shoulder will depend on local conditions and contemplated methods and cost of maintenance. While a natural surface (e.g. turf) may suffice in certain cases, in others, an artificial surface may be required. In any event, the type of surface selected should be such as to avoid the blowing up of debris as well as dust while also meeting the minimum load bearing capability mentioned above.

1.6.6 Under most taxiing conditions, blast velocities are not critical except at intersections where thrusts approach those on breakaway. With the present criteria of up to 25 m wide taxiways, the outboard engines of the larger jets extend beyond the edge of the pavement. For this reason, treatment of taxiway shoulders is recommended to prevent their erosion and to prevent the ingestion of foreign material into jet engines or the blowing of such material into the engines of following aircraft. The material below presents concise information on methods of protection of marginal areas subject to blast erosion and of those areas which must be kept free from debris to prevent ingestion by overhanging turbine engines. Additional information can be found in Appendix 2, 18 to 21.

1.6.7 Studies of engine blast and blast effects have included profile development and velocity contour as related to engine type, aircraft mass and configuration; variation in thrust; and effect of cross-wind. It has been found that the effects of heat associated with the jet wake are negligible. Heat dissipates more rapidly with distance than blast force. Furthermore, personnel, equipment and

structures normally do not occupy the upper limits of those areas where heat is generated during jet operations. Studies indicate that objects in the path of a jet blast are acted upon by several forces including the dynamic pressure associated with the impact of gases as they strike the surface, drag forces set up when viscous gases move past an object, and uplift forces caused by either differential pressures or turbulence.

1.6.8 Cohesive soils, when loosened, are susceptible to erosion by jet blast. For these soils, protection that is adequate against the natural erosive forces of wind and rain will normally be satisfactory. The protection must be a kind that adheres to the clay surfacing so that the jet blast does not strip it off. Oiling or chemical treatment of a cohesive soil surface are possible solutions. The cohesion required to protect a surface from blast erosion is small; normally, a plasticity index (PI) of two or greater will suffice. However, if the area is periodically used by ground vehicles with their equipment, a PI of six or more will be necessary. There should be good surface drainage for these areas if equipment moves over them since this type of surface will be softened by ponding. Special consideration must be given to highly plastic cohesive soils subject to more than about a 5 per cent shrinkage. For these soils, good drainage is very important since they become extremely soft when wet. When dry, these soils crack and become subject to greater lift forces. Fine, cohesionless soils, which are the most susceptible to erosion by blast, are considered to be those which do not have the cohesive properties defined above.

Shoulder and blast pad design thickness

1.6.9 The thickness of taxiway shoulders and blast pads should be able to accommodate an occasional passage of the critical aircraft considered in pavement design and the critical axle load of emergency or maintenance vehicles which may pass over the area. In addition, the following factors should be taken into account:

- a) the minimum design thickness required for shoulder and blast pads to accommodate the critical aircraft can be taken as one half of the total thickness required for the adjacent paved area;
- b) the critical axle load of the heaviest emergency or maintenance vehicle likely to traverse the area should be considered in the determination of the pavement thickness. If this thickness is greater than that based on a) above, then this design thickness should be used for shoulder and blast pads;

- c) for wide body aircraft such as the A330, A340, B767, B777, MD11, L1011 or smaller, the recommended minimum surface thickness, if bituminous concrete on an aggregate base is used, is 5 cm on shoulders and 7.5 cm on blast pads. For aircraft such as the B747 or larger, an increase of 2.5 cm in this thickness is recommended;
- d) the use of a stabilized base for shoulders and blast pads is also recommended. A 5 cm bituminous concrete surface is the recommended minimum on a stabilized base;
- e) the use of Portland cement concrete and a granular sub-base for shoulder and blast pads (or cement-stabilized sand) is advantageous. A minimum thickness of 15 cm of cement concrete is recommended; and
- f) the same compaction and construction criteria for sub-grade and pavement courses in shoulder and blast areas should be used as for full strength pavement areas. It is recommended that a drop-off of approximately 2.5 cm be used at the edge of the full strength pavement, shoulders and blast pads to provide a definite line of demarcation.

1.7 FUTURE AIRCRAFT DEVELOPMENTS

General

1.7.1 Annex 14, Volume I sets forth the minimum aerodrome specifications for aircraft that have the characteristics of those which are currently operating or for similar aircraft that are planned for introduction in the immediate future. The current specifications are therefore intended to accommodate aeroplanes with wing spans of up to 80 m, e.g. Airbus A380-800. Accordingly, any additional safeguards that might be considered appropriate to provide for more demanding aircraft are not taken into account in the Annex. Such matters are left to appropriate authorities to evaluate and take into account as necessary for each particular aerodrome.

1.7.2 The following information may assist these authorities and airport planners to be aware of the way in which the introduction of larger aircraft may alter some of the specifications. In this respect, it is worth noting that it is probable that some increase in current maximum aircraft size may be acceptable without major modifications to

existing aerodromes. However, the upper limit of aircraft size which is examined below is, in all probability, beyond this consideration unless aerodrome procedures are altered, with resulting reduction in aerodrome capacity.

Future aircraft trends

1.7.3 The trends for future aircraft designs may be obtained from various sources, including the aircraft manufacturers and the International Coordinating Council of Aerospace Industries Associations. For the purpose of planning future airport development, the following aircraft dimensions may be used:

wing span	up to 84 m
outer main gear wheel span	up to 20 m
overall length	80 m or more
tail height	up to 24 m
maximum gross mass	583 000 kg or more

Aerodrome data

1.7.4 Using the rationale developed for implementation of certain specifications related to the aerodrome reference code, it is possible that aircraft with the dimensions shown in the previous paragraph could have the effects on the taxiway system described below.

Taxiway width

1.7.5 It is expected that taxiing characteristics of future large aircraft will be similar to those of the largest current aircraft when considering the straight portion of the taxiway. The taxiway width, W_T , for these aircraft is represented by the relationship:

$$W_T = T_M + 2C$$

where:

T_M	=	maximum outer main gear wheel span
C	=	clearance between the outer main gear wheel and the taxiway edge (maximum allowable lateral deviation).

This geometry is shown in Figure 1-18.

1.7.6 Assuming the expected growth of outer main gear wheel span to 20 m and a wheel-to-edge clearance of 4.5 m, the taxiway width for planning purposes comes to 29 m.

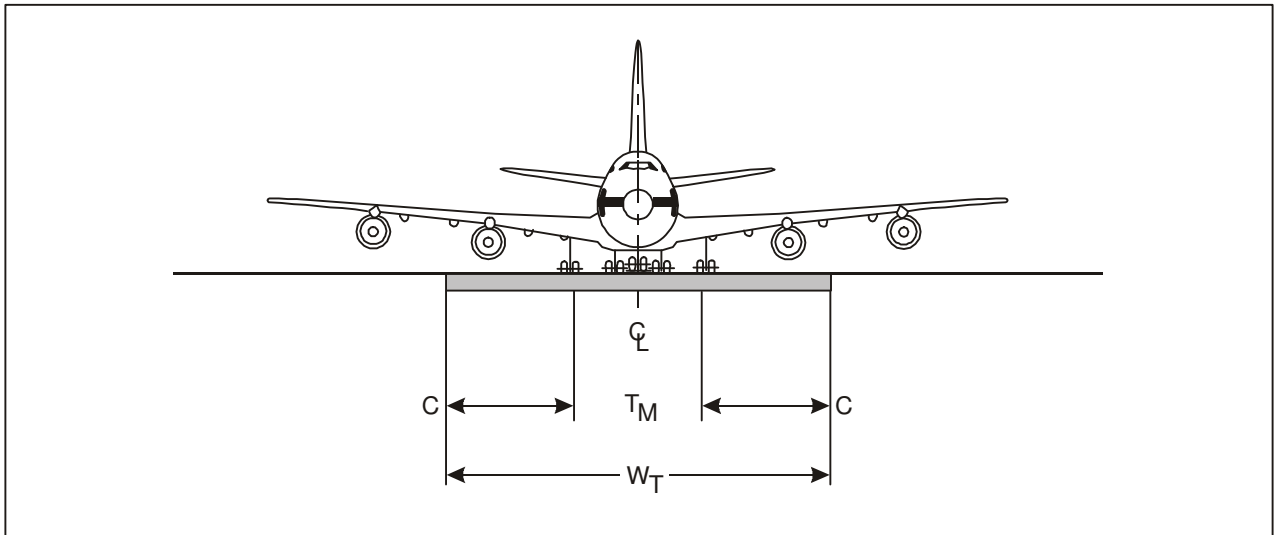

Figure 1-18. Taxiway width geometry

Runway-parallel taxiway separation distance

1.7.7 The separation distance between a runway and a parallel taxiway is currently based on the premise that any part of the aircraft on the taxiway centre line must not protrude into the associated runway strip area. This distance, *S*, is represented by the relationship:

$$S = \frac{1}{2} (SW + WS)$$

where:

SW = strip width

WS = wing span

This geometry is illustrated in Figure 1-19.

1.7.8 The separation distance for planning purposes for the largest aircraft predicted by future trends data is 192 m. This value is based on the assumption that this aircraft, having a wing span of 84 m, can safely operate in the current 300 m runway strip width required for a non-precision or precision approach runway.

Separation between parallel taxiways

1.7.9 The rationale for determining the separation distance between parallel taxiways, one of which may be an apron taxiway, is based on providing a suitable wing tip

clearance when an aircraft has deviated from the taxiway centre line. Primary factors influencing this issue are: wing span (*WS*), main gear wheel clearance (*C*) and wing tip clearance (*Z*). This results in an expression for the separation distance, *S*, of:

$$S = WS + C + Z$$

where:

WS = wing span

C = clearance between the outer main gear wheel and the taxiway edge (maximum allowable lateral deviation)

Z = wing tip clearance (increment) that accounts for aircraft steering performance, pavement surface conditions, and an assured safety buffer to account for unforeseen problems, and to minimize potential adverse impacts on airport capacity.

The geometry of this relationship is shown in Figure 1-20.

1.7.10 The separation distances between parallel taxiways and between parallel taxiways and apron taxiways are considered to be the same since it is assumed that the speed that the aircraft will taxi in both systems is the same. The separation distance, for planning purposes, for a future aircraft span of 84 m, a lateral deviation, *C*, of 4.5 m and a current code F wing tip clearance (increment) of 13 m, is 101.5 m.

Separation distance between taxiway and object

1.7.11 Taxiing speeds on a taxiway and on an apron taxiway are assumed to be the same. Therefore, the separation distances to an object are assumed to be the same in both cases. A rationale has been developed which bases the taxiway-to-object separation distance on a clearance between the wing tip of the aircraft and the object when the aircraft has deviated from the taxiway centre line. This taxiway-to-object separation distance, S , is:

$$S = \frac{WS}{2} + C + Z$$

where:

WS = wing span

C = clearance between the outer main gear wheel and the taxiway edge (maximum allowable lateral deviation)

Z = wing tip clearance to an object (increment); (see explanation above in 1.7.9)

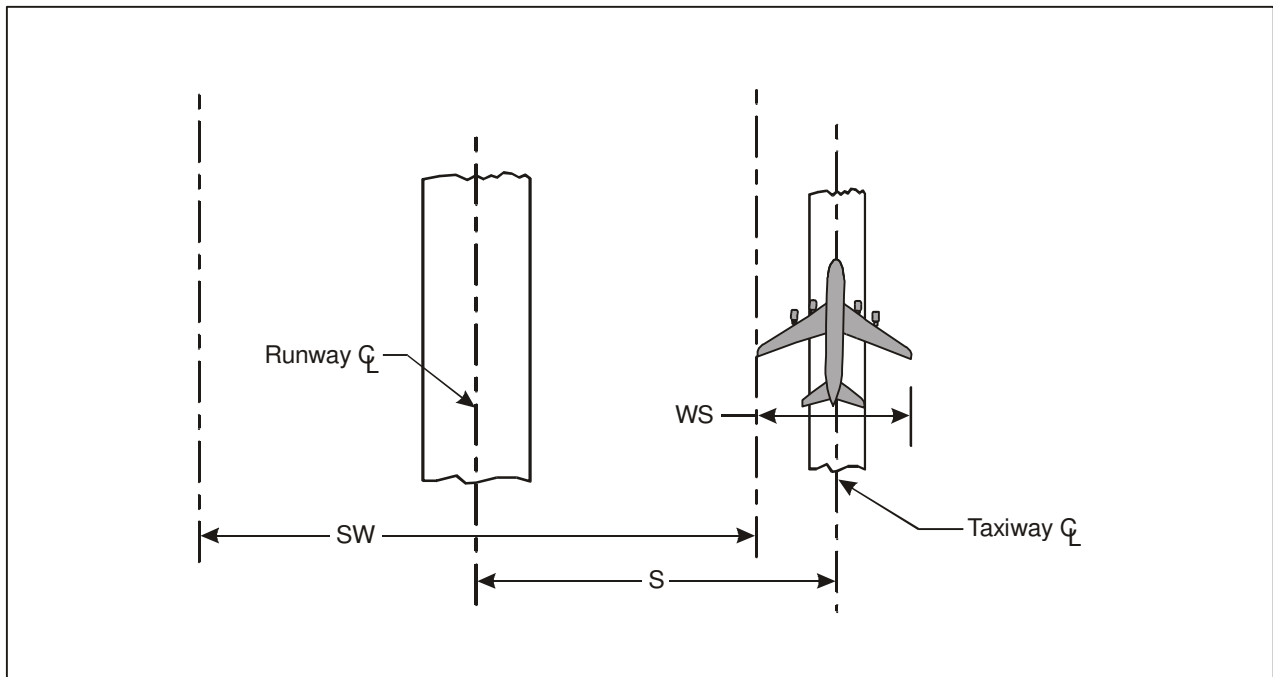

Figure 1-19. Parallel runway-taxiway separation geometry

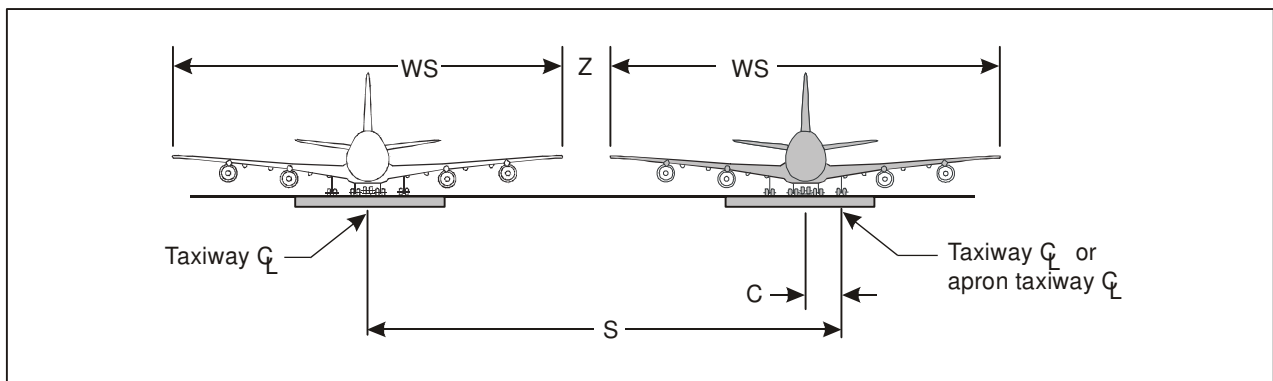

Figure 1-20. Parallel taxiway separation geometry

Figure 1-21 illustrates this geometry.

1.7.12 Application of the above relationship results in a taxiway centre line or apron taxiway centre line-to-object distance of 57 m when using a 4.5 m deviation and a current code F wing tip clearance (increment) of 13 m. The assumed wing span is 86.5 m.

Aircraft stand taxilane-to-object

1.7.13 The lower taxiing speed of an aircraft in a stand taxilane permits a smaller lateral deviation to be considered than with other taxiways. The geometry of Figure 1-22

illustrates the relationship of aircraft clearance to an object in a stand taxilane. Thus the separation distance, S , is found using the following formula:

$$S = \frac{WS}{2} + d + Z$$

where:

WS = wing span

d = lateral deviation

Z = wing tip clearance to an object (increment);
 (see explanation in 1.7.9 above).

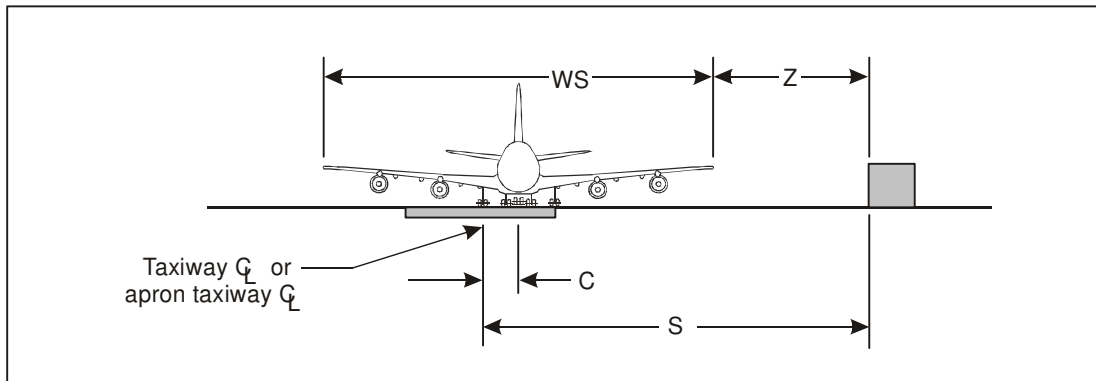

Figure 1-21. Taxiway/apron taxiway-to-object geometry

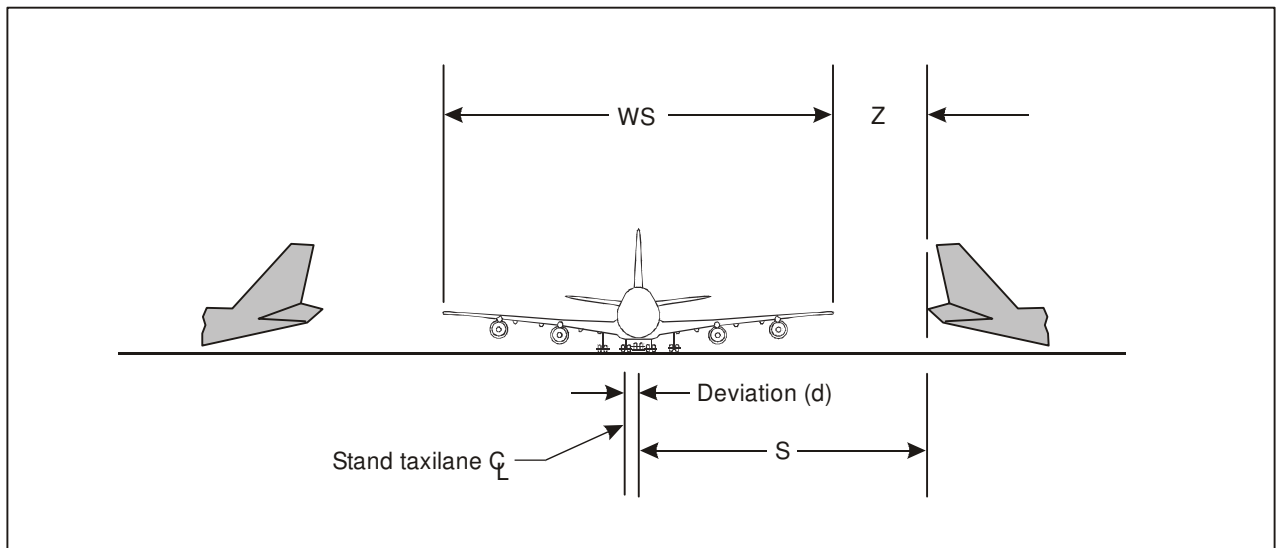

Figure 1-22. Aircraft stand taxilane-to-object geometry

1.7.14 Application of the above rationale results in an object separation distance, for planning purposes, for future large aircraft in a stand taxilane of 54 m. This value is based on a wing span of 84 m, a gear deviation of 3.5 m and a wing tip clearance (increment) of 8.5 m.

Other considerations

1.7.15 In addition to the guidance in the preceding paragraphs, preliminary criteria to accommodate future aircraft development are described below:

Runway width: 60 m

Runway sight distance: Same as current requirement for code letter F

Runway transverse slope: Same as current requirement for code letter F

Runway shoulders: Overall width of runway and shoulder — 75 m. A widened area may need to be prepared to prevent erosion of the adjacent area and foreign object damage

Slope and strength of runway shoulders: Same as current requirement for code letter F

Minimum separation distances between taxiway centre line and runway centre line:

½ wing span (Y)	42 m
+	
½ strip width (non-instrument approach runway)	75 m
Total	117 m

or

½ wing span (Y)	42 m
+	
½ strip width (instrument approach runway)	150 m
Total	192 m

Taxiway pavement and shoulder (overall width): Adequate space should be prepared to prevent erosion of the adjacent area and foreign object damage. The width of that portion of a taxiway bridge capable of supporting aeroplanes shall not be less than the width of the graded area of the strip provided for that taxiway.

Graded portion of taxiway strip (overall width): Adequate space should be prepared to prevent erosion of the adjacent area and foreign object damage. The width of that portion of a taxiway bridge capable of supporting aeroplanes shall not be less than the width of the graded area of the strip provided for that taxiway.

Chapter 2

HOLDING BAYS AND OTHER BYPASSES

2.1 NEED FOR HOLDING BAYS AND OTHER BYPASSES

2.1.1 *Procedures for Air Navigation Services — Air Traffic Management* (Doc 4444), Chapter 7, 7.8.1 — Departure Sequence, states that “departures shall normally be cleared in the order in which they are ready for take-off, except that deviations may be made from this order of priority to facilitate the maximum number of departures with the least average delay”. At low levels of aerodrome activity (less than approximately 50 000 annual operations), there is normally little need to make deviations in the departure sequence. However, for higher activity levels, aerodromes with single taxiways and no holding bays or other bypasses provide aerodrome control units with no opportunity to change the sequence of departures once the aircraft have left the apron. In particular, at aerodromes with large apron areas, it is often difficult to arrange for aircraft to leave the apron in such a way that they will arrive at the end of the runway in the sequence required by air traffic services units.

2.1.2 The provision of an adequate number of holding bay spaces or other bypasses, based upon an analysis of the current and near-term hourly aircraft departure demand, will allow a large degree of flexibility in generating the departure sequence. This provides air traffic services units with greater flexibility in adjusting the take-off sequence to overcome undue delays, thus increasing the capacity of an aerodrome. In addition, holding bays or other bypasses allow:

- a) departure of certain aircraft to be delayed owing to unforeseen circumstances without delaying the following aircraft (for instance, a last minute addition to the payload or a replacement of defective equipment);
- b) aircraft to carry out pre-flight altimeter checks and alignment and programming of airborne inertial navigation systems when this is not possible on the apron;

- c) engine runups for piston aircraft; and
- d) establishment of a VOR aerodrome check-point.

2.2 TYPES OF BYPASSES

2.2.1 In general, taxiway features that allow an aircraft to bypass a preceding aircraft can be divided into three types:

- a) *Holding bays*. A defined area where aircraft can be held or bypassed. Figure 2-1 shows some examples of holding bay configurations and Figure 2-2 gives a detailed example of a holding bay, located at the taxi-holding position.
- b) *Dual taxiways*. A second taxiway or a taxiway bypass to the normal parallel taxiway. Figure 2-3 shows some examples.
- c) *Dual runway entrances*. A duplication of the taxiway entrance to the runway. Some examples are shown in Figure 2-4.

2.2.2 If a holding bay is used, aircraft can, on the basis of their priority, take off in the order as cleared by ATC. The availability of a holding bay allows aircraft to leave and independently re-enter the departure stream. A detailed example of the pavement area for a holding bay located at the taxi-holding position is shown in Figure 2-2. This design is for a non-precision or a precision approach runway where the code number is 3 or 4 and incorporates an aircraft wing-tip-to-wing-tip clearance of 15 m when both aircraft are centred on the centre line. Holding bay design for other runway types or locations along the taxiway will have proportional dimensional requirements.

2.2.3 Dual taxiways or taxiway bypasses can only achieve relative departure priority by separating the

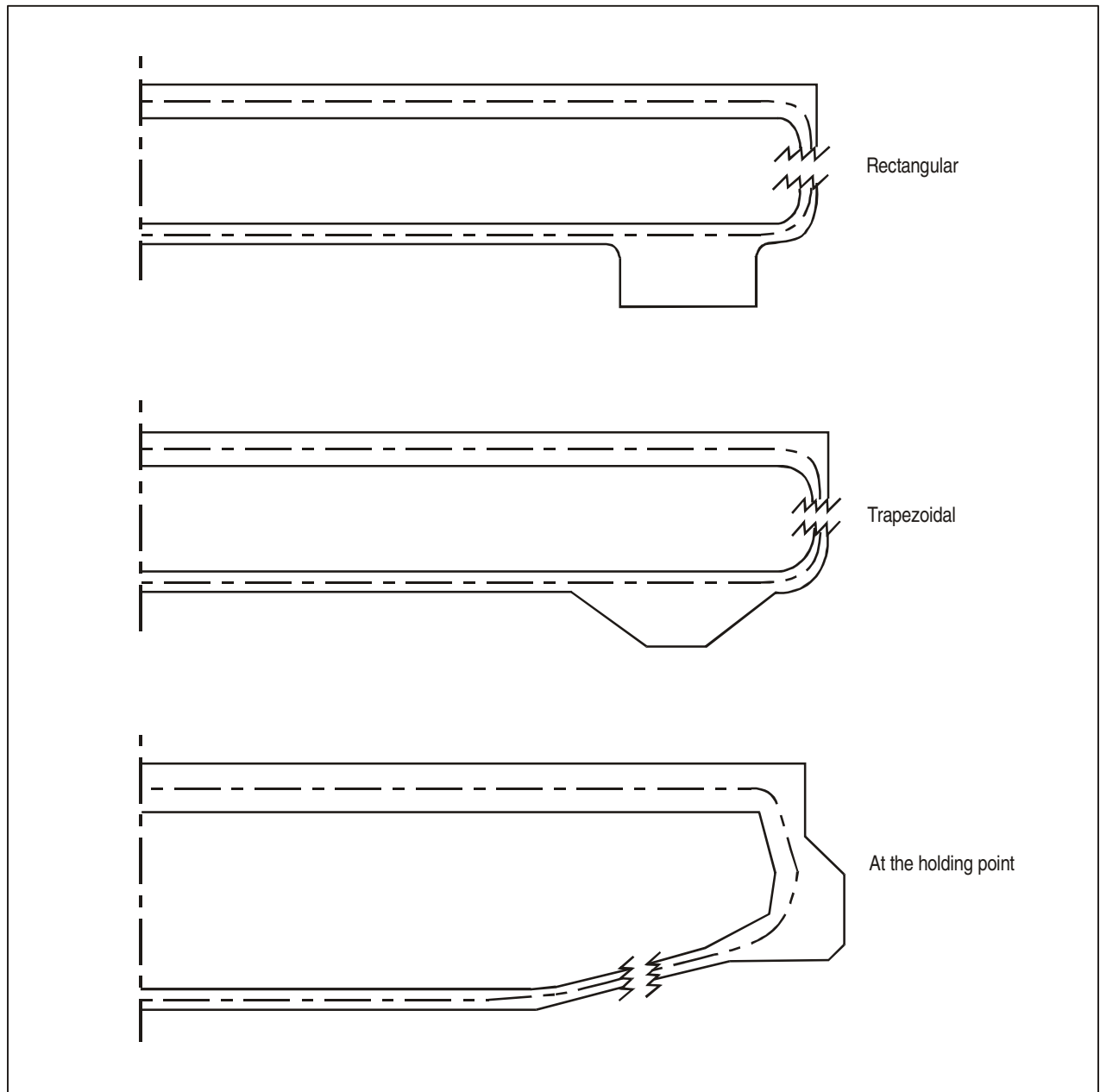

Figure 2-1. Examples of holding bay configurations

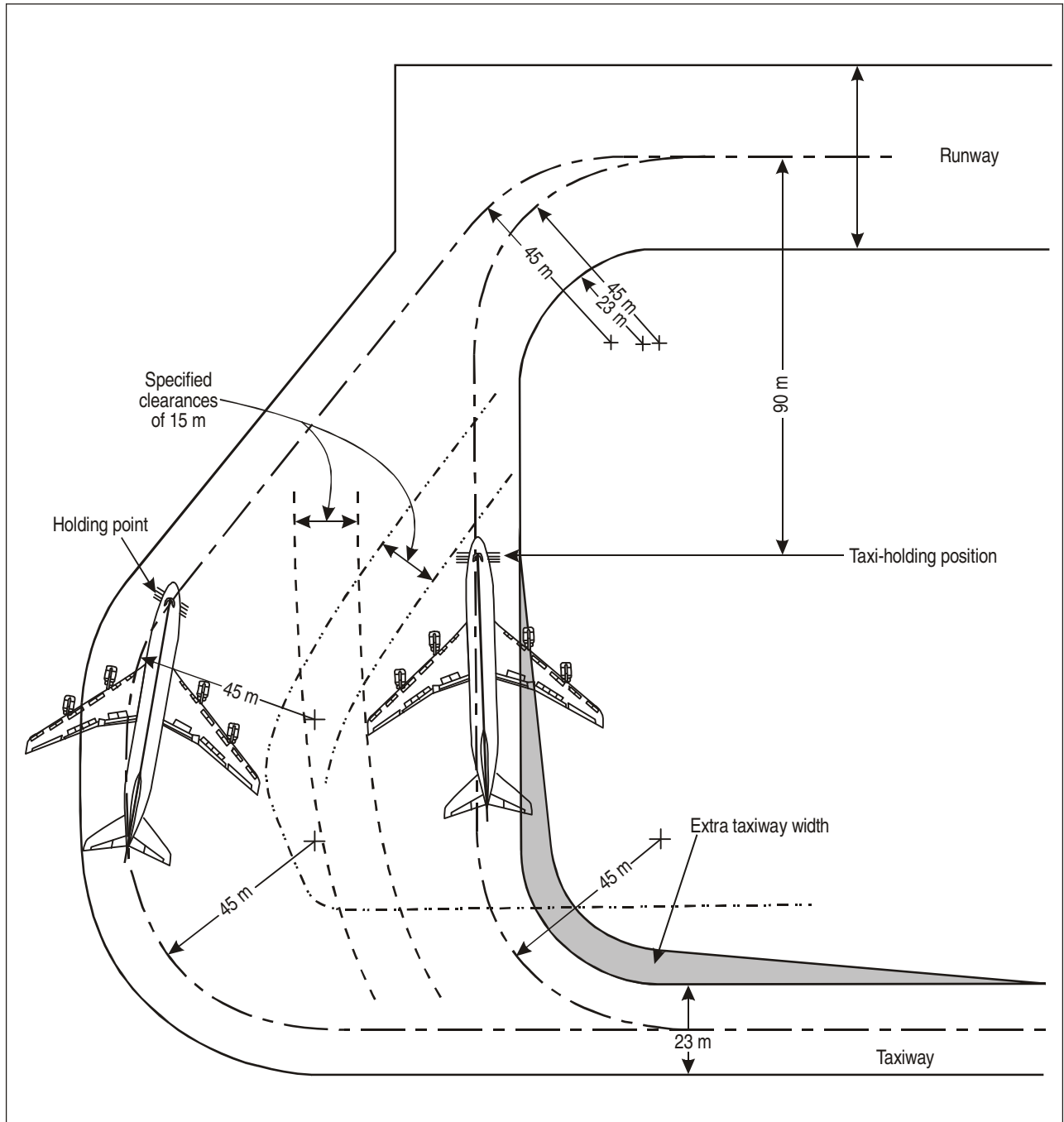

Figure 2-2. Detailed example of holding bay

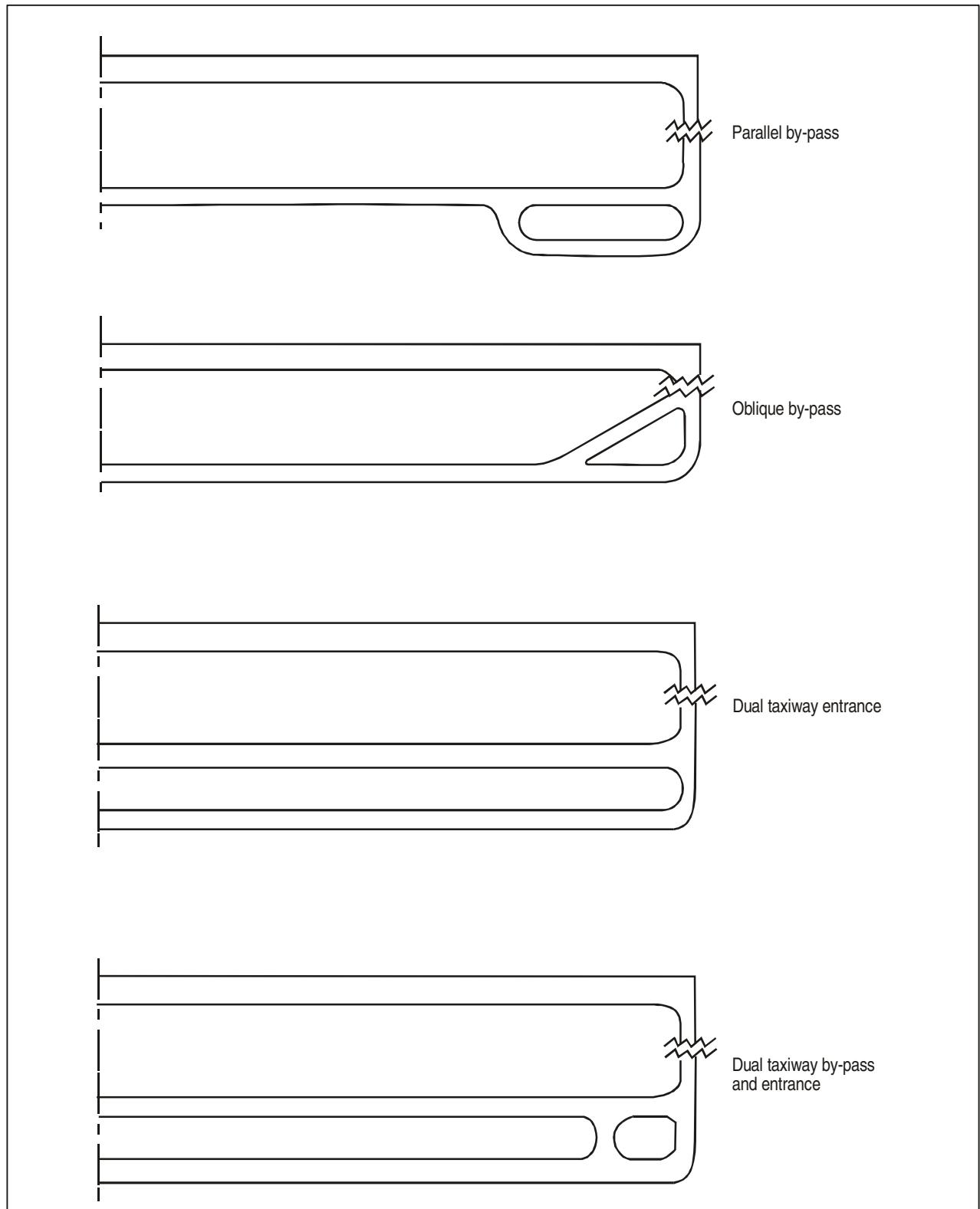

Figure 2-3. Examples of dual taxiways

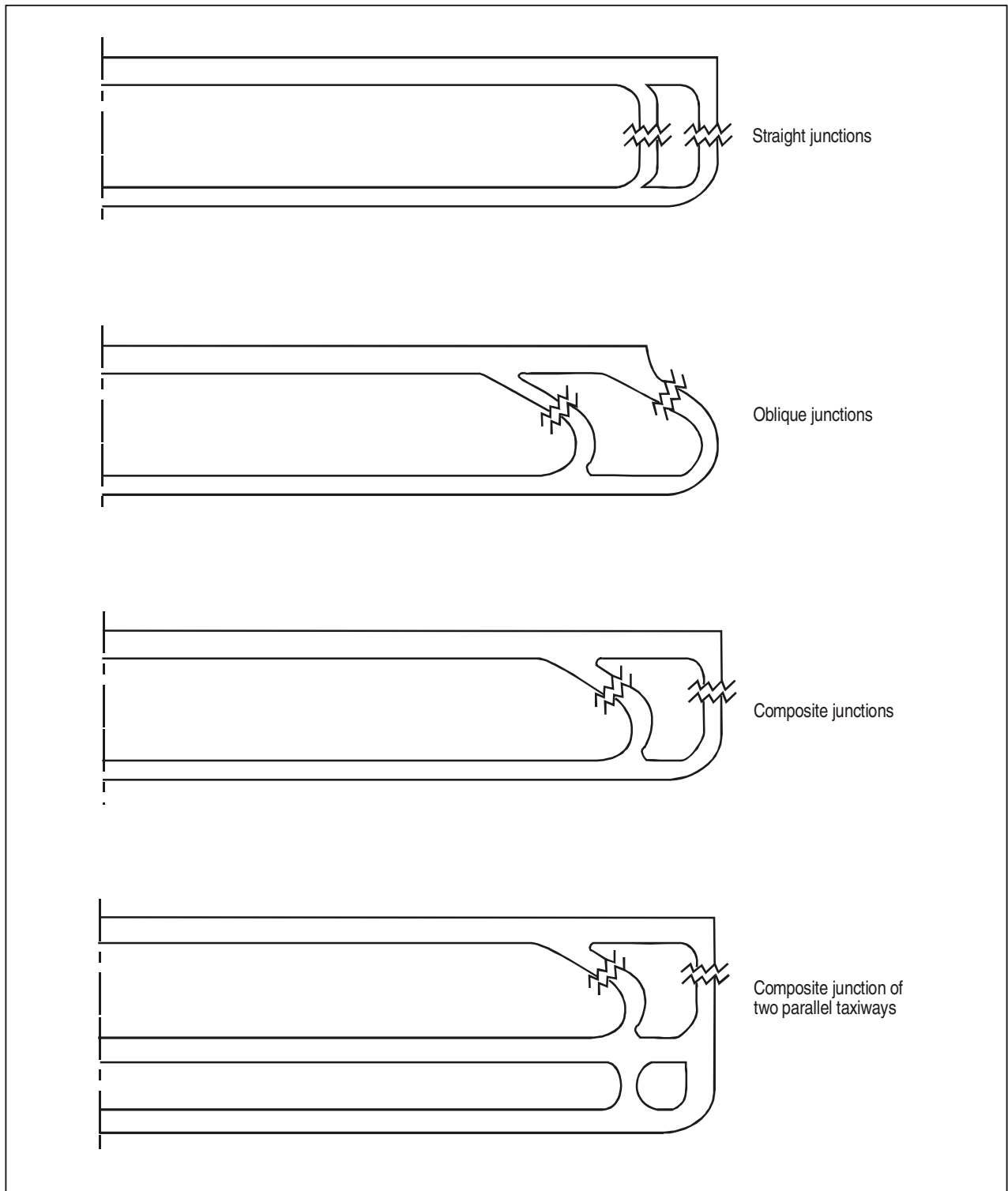

Figure 2-4. Examples of dual runway entrances

departure stream into two parts. Taxi bypasses can be constructed at a relatively low cost, but provide only a small amount of flexibility to alter the departure sequence. A full length dual taxiway is the most expensive alternative and can only be justified at very high activity aerodromes where there is a clear need for two-directional movement parallel to the runway. This need arises when passenger terminal aprons or other facilities are located in such a manner that they generate aircraft movements opposite to the departure flow.

2.2.4 The dual runway entrance reduces the take-off run available for aircraft using the entrance not located at the extremity of the runway. This is not a serious disadvantage if this entrance can be used by aircraft for which the remaining take-off run is adequate. A dual runway entrance also makes it possible to bypass an aircraft delayed on another entrance taxiway or even at the extremity of the runway. The use of dual entrances in combination with dual taxiways will give a degree of flexibility comparable to that obtained with a well-designed holding bay. Oblique entrances permit entry at some speed, but they make it more difficult for the crew to see aircraft approaching to land and, because of the larger paved area required, they are more expensive to provide. Though operational and traffic control groups have advocated designs for runway entry which would permit acceleration while turning onto the runway, further studies, simulations and experience will be necessary prior to establishing a recommended design of this type.

2.2.5 For a given aerodrome, the best choice between these methods depends upon the geometry of the existing runway/taxiway system and the volume of aircraft traffic. Experience shows that local technical and economic considerations will often be decisive when choosing between the three types (or combinations of types). These three types can also be used in various combinations to optimize surface movements of aircraft to the threshold.

2.3 COMMON DESIGN REQUIREMENTS AND CHARACTERISTICS

2.3.1 Regardless of the type of bypass used, minimum centre line to centre line separations between taxiways and runways must be maintained as required for the type of runway served (see Table 1-1).

2.3.2 The cost of constructing any bypass is directly related to the area of new pavement required. In addition, indirect costs may result from disruptions to air traffic during the construction period.

2.3.3 The design selected should always provide at least one entrance to the beginning of the runway usable for take-off so that aircraft requiring the entire take-off run may easily align themselves for take-off without significant loss of runway length.

2.3.4 Propeller wash and jet blast from holding aircraft should be directed away from other aircraft and away from the runway. The preparation and the maintenance of the shoulders should be as described for taxiway shoulders (see 1.6.5 to 1.6.9).

2.4 SIZE AND LOCATION OF HOLDING BAYS

2.4.1 The space required for a holding bay depends on the number of aircraft positions to be provided, the size of the aircraft to be accommodated and the frequency of their utilization. The dimensions must allow for sufficient space between aircraft to enable them to manoeuvre independently. The information given in Chapter 3 on size of aircraft stands also applies to holding bays. In general, the wing tip clearance (increment) between a parked aircraft and one moving along the taxiway or apron taxiway should not be less than that given by the following tabulation:

Code letter	Wing tip clearance (increment) (m)
A	7.25
B	7.25
C	5
D	10
E	10.5
F	13.0

2.4.2 When used to allow flexible departure sequencing, the most advantageous location for a holding bay is adjacent to the taxiway serving the runway end. Other locations along the taxiway are satisfactory for aircraft performing pre-flight checks or engine runups or as a holding point for aircraft awaiting departure clearance. Criteria for the location of holding bays with respect to the runway are given below.

2.4.3 The distance between a holding bay and the centre line of a runway should be in accordance with Table 2-1 and, in the case of a precision approach runway, should be such that a holding aircraft will not interfere with the operation of radio aids. Therefore, the aircraft should be

clear of the ILS sensitive and critical areas, and it should not penetrate the obstacle free zone.

2.4.4 At elevations greater than 700 m, the distance of 90 m specified in Table 2-1 for a precision approach runway code number 4 should be increased as follows:

- a) up to an elevation of 2 000 m — 1 m for every 100 m in excess of 700 m;
- b) elevation in excess of 2 000 m and up to 4 000 m — 13 m plus 1.5 m for every 100 m in excess of 2 000 m; and
- c) elevation in excess of 4 000 m and up to 5 000 m — 43 m plus 2 m for every 100 m in excess of 4 000 m.

2.4.5 If a holding bay for a precision approach runway code number 4 is at a higher elevation compared to the threshold, the distance of 90 m specified in Table 2-1 should be further increased 5 m for every metre the bay is higher than the threshold.

2.4.6 The distance of 107.5 m for code number 4 where the code letter is F is based on an aircraft with a tail height of 24 m, a distance from the nose to the highest part of the tail of 62.2 m, a nose height of 10 m, holding at an angle of 45 degrees or more with respect to the runway centre line and being clear of the obstacle free zone.

2.4.7 The distance of 90 m for code number 3 or 4 is based on an aircraft with a tail height of 20 m, a distance from the nose to the highest part of the tail of 52.7 m and a nose height of 10 m, holding at an angle of 45 degrees or more with respect to the runway centre line, being clear of the obstacle free zone and not accountable for the calculation of obstacle clearance altitude/height.

2.4.8 The distance of 60 m for code number 1 or 2 is based on an aircraft with a tail height of 8 m, a distance from the nose to the highest part of the tail of 24.6 m and a nose height of 5.2 m, holding at an angle of 45 degrees or more with respect to the runway centre line, being clear of the obstacle free zone.

2.5 HOLDING BAY MARKING AND LIGHTING

To facilitate accurate manoeuvring of aircraft on the holding bays, it is desirable to provide suitable marking and lighting. These will also prevent parked aircraft from interfering with the passage of other aircraft moving along the adjacent taxiway. A solid line to be followed by the pilot of the aircraft appears to be a suitable method. Taxiway edge lighting should be provided on a holding bay intended for night use. Location and characteristics of the lights should be in accordance with the specifications for taxiway lighting set out in Annex 14, Volume I, Chapter 5.

Table 2-1. Minimum distance from the runway centre line to a holding bay

Type of runway operation	Code number			
	1	2	3	4
Non-instrument and take-off	30 m	40 m	75 m	75 m
Non-precision approach	40 m	40 m	75 m	75 m
Precision approach Category I	60 m ^b	60 m ^b	90 m ^{a,b}	90 m ^{a,b}
Precision approach Category II or III	—	—	90 m ^{a,b}	90 m ^{a,b,c}

- a. If a holding bay is at a lower elevation compared to the threshold, the distance may be decreased 5 m for every metre the bay is lower than the threshold, contingent upon not infringing on the inner transitional surface.
- b. This distance may need to be increased to avoid interference with radio aids; for a precision approach runway category III the increase may be of the order of 50 m.
- c. Where the code letter is F, this distance should be 107.5 m.

Chapter 3

APRONS

An apron is a defined area intended to accommodate aircraft for purposes of loading and unloading passengers, mail or cargo, fuelling and parking or maintenance. The apron is generally paved but may occasionally be unpaved; for example, in some instances, a turf parking apron may be adequate for small aircraft.

layovers or for light periodic servicing and maintenance of temporarily grounded aircraft. While parking aprons are removed from the terminal aprons, they should be located as close to them as is practical to minimize the time for passenger loading/unloading as well as from a security point of view.

3.1 TYPES OF APRONS

Service and hangar aprons

Passenger terminal apron

3.1.1 The passenger terminal apron is an area designed for aircraft manoeuvring and parking that is adjacent or readily accessible to passenger terminal facilities. This area is where passengers board the aircraft from the passenger terminal. In addition to facilitating passenger movement, the passenger terminal apron is used for aircraft fuelling and maintenance as well as loading and unloading cargo, mail and baggage. Individual aircraft parking positions on the passenger terminal apron are referred to as aircraft stands.

3.1.4 A service apron is an uncovered area adjacent to an aircraft hangar on which aircraft maintenance can be performed, while a hangar apron is an area on which aircraft move into and out of a storage hangar.

General aviation aprons

3.1.5 General aviation aircraft, used for business or personal flying, require several categories of aprons to support different general aviation activities.

Cargo terminal apron

3.1.2 Aircraft that carry only freight and mail may be provided a separate cargo terminal apron adjacent to a cargo terminal building. The separation of cargo and passenger aircraft is desirable because of the different types of facilities each requires both on the apron and at the terminal.

Itinerant apron

3.1.5.1 Itinerant (transient) general aviation aircraft use the itinerant apron as temporary aircraft parking facilities and to access fuelling, servicing and ground transportation. At aerodromes servicing only general aviation aircraft, the itinerant apron is usually adjacent to, or an integral part of, a fixed-based operator's area. The terminal apron will generally also set aside some area for itinerant general aviation aircraft.

Remote parking apron

3.1.3 In addition to the terminal apron, airports may require a separate parking apron where aircraft can park for extended periods. These aprons can be used during crew

Base aircraft aprons or tiedowns

3.1.5.2 General aviation aircraft based at an aerodrome require either hangar storage or a tiedown space in the open. Hangared aircraft also need an apron in front of the building for manoeuvring. Open areas used for base

aircraft tiedown may be paved, unpaved or turf, depending on the size of aircraft and local weather and soil conditions. It is desirable that they be in a separate location from the itinerant aircraft aprons.

Other ground servicing aprons

3.1.5.3 Areas for servicing, fuelling or loading and unloading should also be provided as needed.

3.2 DESIGN REQUIREMENTS

3.2.1 The design of any of the various apron types requires the evaluation of many interrelated and often contradictory characteristics. Despite the distinct purposes of the different apron types, there are many general design characteristics relating to safety, efficiency, geometry, flexibility and engineering that are common to all types. The following paragraphs give a brief description of these general design requirements.

Safety

3.2.2 Apron design should take into account safety procedures for aircraft manoeuvring on the apron. Safety in this context implies that aircraft maintain specified clearances and follow the established procedures to enter, move within and depart from apron areas. Services provided to aircraft parked on the apron should incorporate safety procedures, especially regarding aircraft fuelling. Pavements should slope away from terminal buildings and other structures to prevent the spread of fuel fires on the apron. Water outlets should be located at each stand position for routine hosing of the apron surface. Aircraft security should also be considered in locating the apron area where the aircraft can be protected from unauthorized personnel. This is accomplished by physically separating public access areas from the apron areas.

Efficiency

3.2.3 Apron design should contribute to a high degree of efficiency for aircraft movements and dispensing apron services. Freedom of movement, minimum taxi distances and a minimum of delay for aircraft initiating movements on the apron are all measures of efficiency for any of the apron types. If the ultimate aircraft stand arrangement can

be determined during the initial planning phase of the aerodrome, utilities and services should be installed in fixed installations. Fuel lines and hydrants, compressed air hook-ups and electrical power systems must be carefully pre-planned because these systems are often placed under the apron pavement. The high initial cost of these systems will be offset by the increased efficiency of the stand, which allows greater utilization of the apron. Achieving these measures of efficiency will ensure the maximum economic value of the apron.

Geometry

3.2.4 The planning and design of any apron type are dependent upon a number of geometric considerations. For example, the length and width of a land parcel available for apron development may preclude the choice of certain apron layout concepts. For a new aerodrome it may be possible to develop the most efficient arrangement, based upon the nature of the demand, and then to set aside an area of land ideally suited to the plan. However, expansion or addition of aprons at existing aerodromes will usually be less than ideal due to the limitations imposed by the shape and size of available parcels. The overall area needed per aircraft stand includes the area required for aircraft stand taxilanes as well as apron taxiways used in common with other aircraft stands. Therefore, the overall area needed for apron development is a function not only of aircraft size, clearances and parking method, but also of the geometric arrangement of aircraft stand taxilanes, other taxiways, blast fences, areas used for the stationing of service vehicles and roads for the movement of ground vehicles.

Flexibility

3.2.5 Planning for aprons should include an evaluation of the following flexibility characteristics.

Range of aircraft sizes

3.2.5.1 The number and size of aircraft stands should be matched to the number and size of aircraft types expected to use the apron. A compromise must be developed between the extremes of:

- a) using one size of aircraft stand large enough for the largest aircraft type; and
- b) using as many different sized stands as there are aircraft types.

The first method is a highly inefficient use of area, while the second provides a low level of operating flexibility. For passenger terminal aprons, a compromise solution that achieves adequate flexibility is to group the aircraft into two to four size classes and provide stands for a mix of these general sizes in proportion to the demand forecast. A greater number of general aviation parking space sizes can be used because the space may be leased and occupied by a single aircraft of known dimensions.

Expansion capability

3.2.5.2 Another key element of a flexible apron system is allowance for expansion to meet future needs. To avoid undue restriction of the growth potential of a particular apron area, the apron should be designed in modular stages so that successive stages become integral additions to the existing apron with a minimum of disruption to ongoing activities.

Common design characteristics

3.2.6 Many technical design requirements for the construction of apron surfaces are common to all apron types. Several of these factors are described in the following paragraphs.

Pavement

3.2.6.1 The choice of pavement surface is determined by evaluating aircraft mass, load distribution, soil conditions and the relative cost of alternative materials. Reinforced concrete is routinely used at aerodromes serving the largest commercial aircraft where greater strength and durability are needed. As a minimum, most aerodromes require an asphalt (tarmac) surface to satisfy strength, drainage and stabilization criteria, though turf and cement-stabilized sand aprons have been satisfactorily used in some locations. Reinforced concrete is usually more expensive to install than asphalt but is less expensive to maintain and usually lasts longer. In addition, concrete is relatively unaffected by spilled jet fuel, whereas asphalt surfaces are damaged if fuel remains on the surface for even short periods of time. This problem can be partially overcome by coating the asphalt with special sealants and by frequently washing off the pavement.

Pavement slope

3.2.6.2 Slopes on an apron should be sufficient to prevent accumulation of water on the surface of the apron

but should be kept as level as drainage requirements permit. Efficient storm drainage of large, paved apron areas is normally achieved by providing a steep pavement slope and numerous area drains. On aprons, however, too great a slope will create manoeuvrability problems for aircraft and service vehicles operating on the apron. Additionally, fuelling of aircraft requires nearly a level surface to achieve the proper fuel mass balance in the assorted aircraft storage tanks. The design of slopes and drains should direct spilled fuel away from building and apron service areas. In order to accommodate the needs for drainage, manoeuvrability and fuelling, apron slopes should be 0.5 to 1.0 per cent in the aircraft stand areas and no more than 1.5 per cent in the other apron areas.

Jet blast and propeller wash

3.2.6.3 The effects of extreme heat and air velocities from jet and propeller engines must be considered when planning apron areas and adjacent service roads and buildings. For some aerodromes, it may be necessary to provide greater aircraft-to-aircraft separations or erect blast fences between parking spaces to counteract these effects. Appendix 2 gives greater detail on this design consideration.

3.3 BASIC TERMINAL APRON LAYOUTS

General considerations

3.3.1 The type of terminal apron parking layout best suited to a particular aerodrome is a function of many inter-related criteria. Design of the terminal apron must, of course, be completely consistent with the choice of terminal design and vice versa. An iterative procedure for selecting the best combination of apron and terminal design should be used to compare the advantages and disadvantages of each system analysed separately. The volume of aircraft traffic using the terminal is an important factor in determining the apron layout that is most efficient in serving a particular terminal design. In addition, an aerodrome with a disproportionate percentage of international transfer (direct connection with another flight) or locally originating passengers may need a specialized terminal and apron system design to accommodate the skewed characteristic of the passenger traffic.

Passenger loading

3.3.2 The passenger loading method to be used must be taken into account when planning the apron layout. Some methods can be used with only one or two of the basic parking layouts.

3.3.2.1 Direct upper level loading is made possible by the development of the loading bridge, permitting the passenger to board the aircraft from the upper level of the terminal building. Two types of aircraft loading bridges are illustrated in Figure 3-1:

- a) *The stationary loading bridge.* A short loading bridge which extends from a projection in the building. The aircraft parks nose-in alongside the projection and stops with the aircraft front door opposite the bridge. The bridge extends a very short distance to the aircraft, allowing very little variation between the height of the aircraft main deck and the terminal floor.
- b) *The apron drive loading bridge.* A bridge which has one end of a telescoping gangway hinged to the terminal building and the other end supported by a steerable, powered dual-wheel. The bridge pivots towards the aircraft and lengthens until it reaches the aircraft door. The end mating with the aircraft can be raised or lowered significantly, permitting aircraft of varying deck heights to be served from the loading bridge.

3.3.2.2 There are other basic passenger loading methods used in addition to aircraft loading bridges:

- a) *Movable steps.* Movable steps are pushed or driven to the aircraft and set at door level. Passengers walk in the open on the apron or are driven by bus between the terminal and the aircraft and use the steps to board the aircraft.
- b) *Passenger transporters.* Passengers board a bus or specially designed passenger transporter at the terminal building and are driven to a remote aircraft stand. Passengers then may use steps to board the aircraft or board the aircraft from the same level as the aircraft floor, i.e. by elevation of the vehicle.
- c) *Aircraft-contained steps.* This procedure is similar to the movable steps and can be used with any aircraft equipped with self-contained steps. After stopping, the crew releases the self-contained steps

and passengers walk on the apron or are driven by bus between the aircraft and the terminal building.

Passenger terminal apron concepts

3.3.3 The design of passenger terminal aprons is directly interrelated with the passenger terminal concept. Determination of passenger terminal concepts is described in the *Airport Planning Manual* (Doc 9184), Part 1 — Master Planning. Various apron/terminal concepts are illustrated in Figure 3-2, and the characteristics of each concept from the viewpoint of the apron are briefly described below.

Simple concept

3.3.4 This concept is to be applied at low traffic volume airports. Aircraft are normally parked angled either nose-in or nose-out for self-taxi in and taxi out. Consideration should be given to providing adequate clearance between apron edge and air-side terminal frontage to reduce the adverse effects of jet engine blast. Where this is not done, jet engine blast fences should be provided. Apron expansion can be done incrementally in accordance with demands, causing little disruption to airport operation.

Linear concept

3.3.5 The linear concept may be regarded as an advanced stage of the simple concept. Aircraft can be parked in an angled or parallel parking configuration. However, the nose-in/push-out parking configuration with minimum clearance between apron edge and terminal is more common in this concept because of more efficient utilization of apron space and handling of aircraft and passengers. Nose-in parking affords relatively easy and simple manoeuvring for aircraft taxiing into gate position. Push-out operations cause little disruption of apron activities in neighbouring gate positions. However, towing tractors and skilled operators are required. At busy traffic airports, it may become necessary to provide double apron taxiways to lessen the blocking of the taxiway by push-out operations. The corridor between the apron edge and terminal frontage can be used for circulation of apron traffic, and the area around the nose of the parked aircraft can be used for ground service equipment parking slots. When apron depth is planned from the outset to cater to the longest fuselage length, the linear concept has as much flexibility and expansibility as the simple concept and almost as much as the open apron concept.

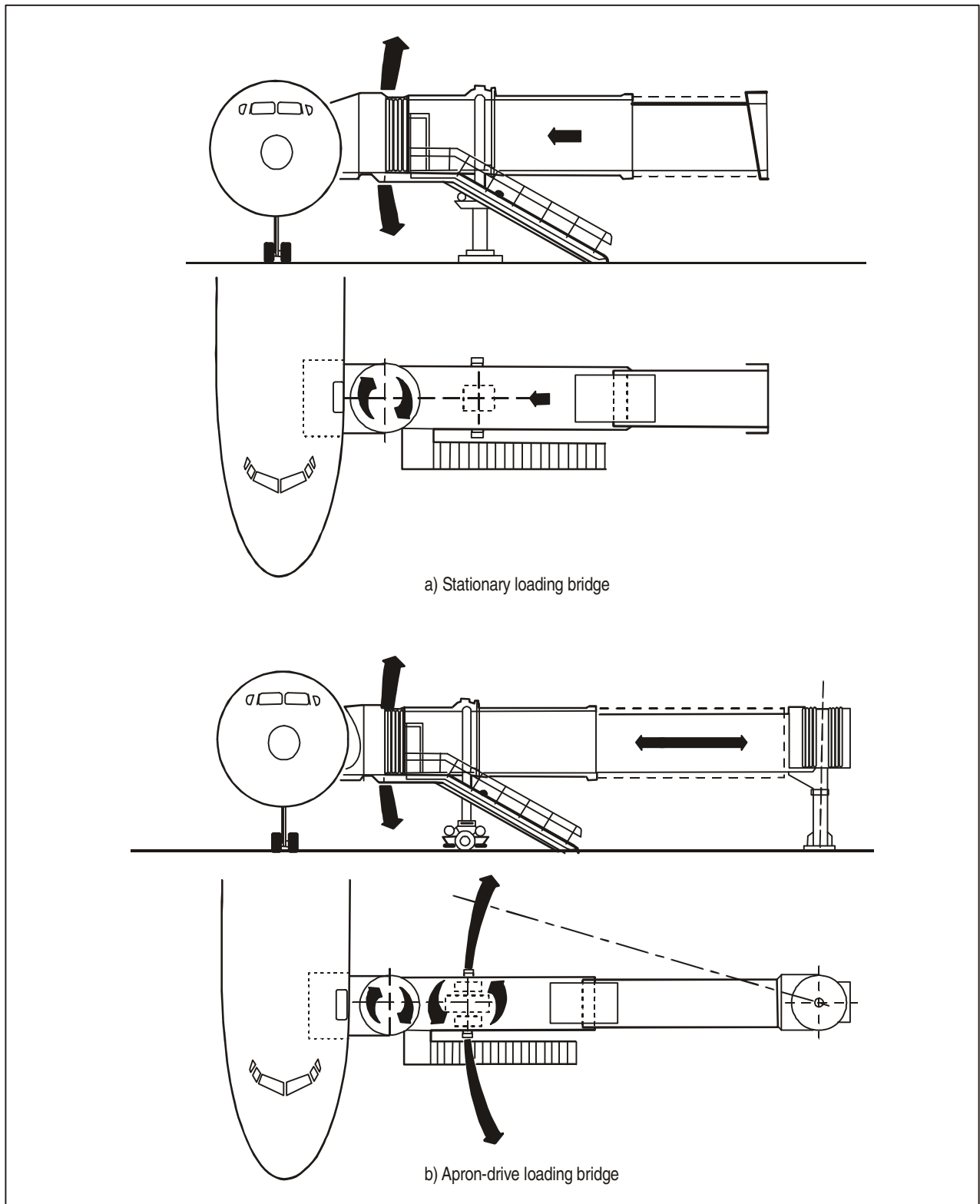

Figure 3-1. Passenger loading bridges

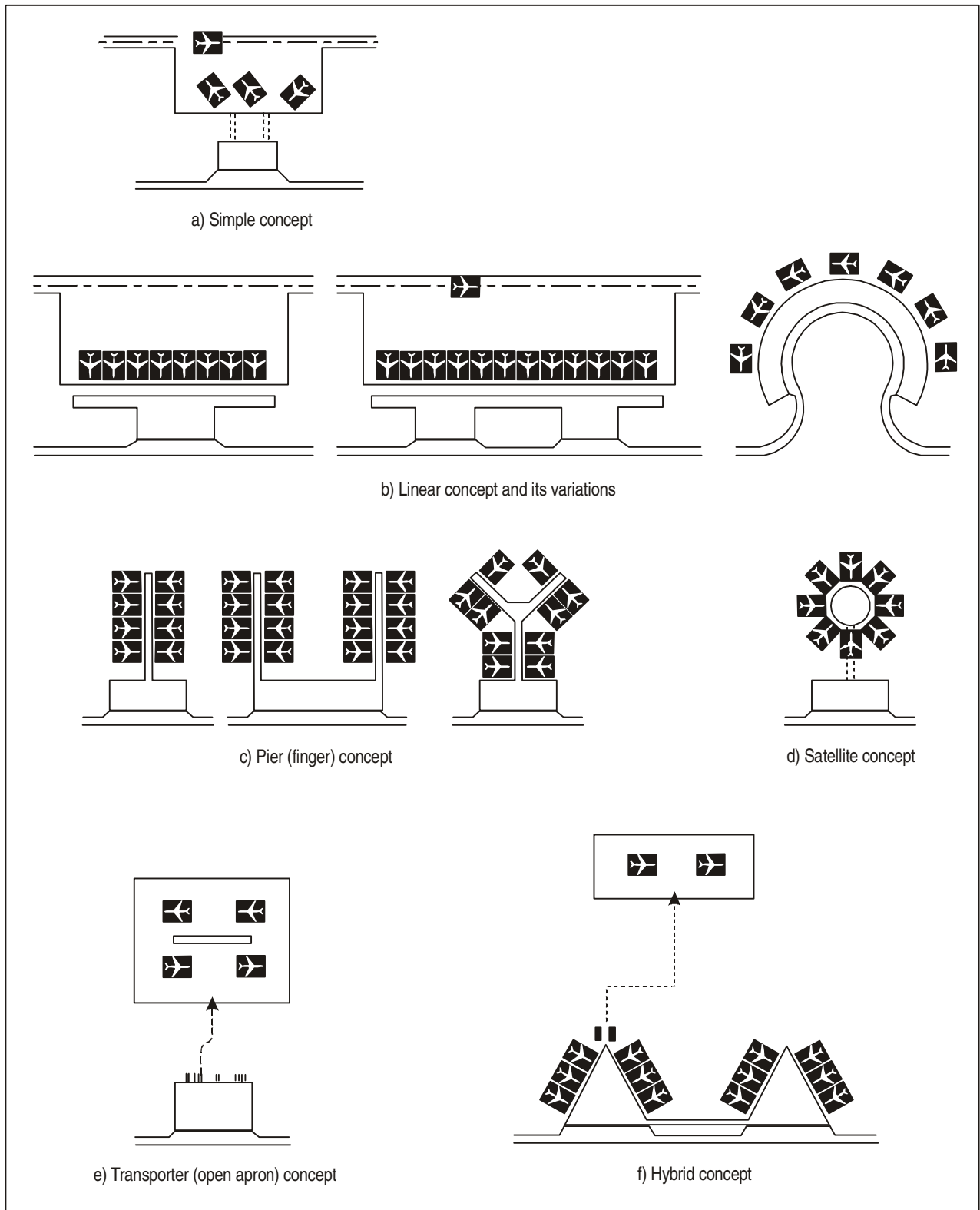

Figure 3-2. Passenger terminal apron concepts

Pier (finger) concept

3.3.6 As seen in Figure 3-2, there are several variations on this concept, according to the shape of the pier. Aircraft can be parked at gate positions on both sides of the piers, either angled, parallel or perpendicular (nose-in). Where there is only a single pier, most advantages of the linear concept would apply for air side activities with the exception that the pier concept has a limited incremental expansion capability. When there are two or more piers, care must be taken to provide proper space between them. If each pier serves a large number of gates, it may be necessary to provide double taxiways between piers to avoid conflicts between aircraft entering and leaving the gate positions. It is important to provide sufficient space between two or more piers to cater to future larger aircraft.

Satellite concept

3.3.7 The satellite concept consists of a satellite unit, surrounded by aircraft gate positions, separated from the terminal. The passenger access to a satellite from the terminal is normally via an underground or elevated corridor to best utilize the apron space, but it could also be on the surface. Depending on the shape of the satellite, the aircraft are parked in radial, parallel or some other configuration around the satellite. When aircraft are parked radially, push-back operation is easy but requires larger apron space. If a wedge-shaped aircraft parking configuration is adopted, it not only requires unfavourable sharp turns taxiing to some of the gate positions but also creates traffic congestion of ground service equipment around the satellite. A disadvantage of this concept is the difficulty of incremental expansion which means that an entire new unit would need to be constructed when additional gate positions are required.

Transporter (open) apron concept

3.3.8 This concept may be referred to as an open or remote apron or transporter concept. As aprons may be ideally located for aircraft, i.e. close to the runway and remote from other structures, this concept would provide advantages for aircraft handling, such as shorter overall taxiing distance, simple self-manoeuvring, ample flexibility and expansibility of aprons. However, as it requires transporting passengers, baggage and cargo for relatively longer distances by transporters (mobile lounges/buses) and carts to and from the terminal, it can create traffic congestion problems on the air side.

Hybrid concept

3.3.9 The hybrid concept means the combining of more than one of the above-mentioned concepts. It is fairly common to combine the transporter concept with one of the other concepts to cater to peak traffic. Aircraft stands located at remote areas from the terminal are often referred to as remote aprons or remote stands.

3.4 SIZE OF APRONS

General

3.4.1 The amount of area required for a particular apron layout depends upon the following factors:

- a) the size and manoeuvrability characteristics of the aircraft using the apron;
- b) the volume of traffic using the apron;
- c) clearance requirements;
- d) type of ingress and egress to the aircraft stand;
- e) basic terminal layout or other airport use (see 3.3);
- f) aircraft ground activity requirements; and
- g) taxiways and service roads.

Aircraft size

3.4.2 The size and manoeuvrability of the mix of aircraft expected to use a given apron must be known before a detailed apron design can be undertaken. Figure 3-3 shows the dimensions needed for sizing an aircraft stand space, and Table 3-1 lists dimensions for some typical aircraft. The overall aircraft size dimensions — total length (L) and wing span (S) — can be used as the starting point in establishing the overall apron area requirement for an aerodrome. All other areas needed for clearances, taxiing, servicing, etc., must be determined with regard to this basic aircraft “footprint”. The manoeuvrability characteristics of an aircraft are a function of the turning radius (R) which is in turn related to the location of the aircraft turning centre. The turning centre is the point about which the aircraft pivots when turning. This point is located along the centre line of the main undercarriage at a variable distance from

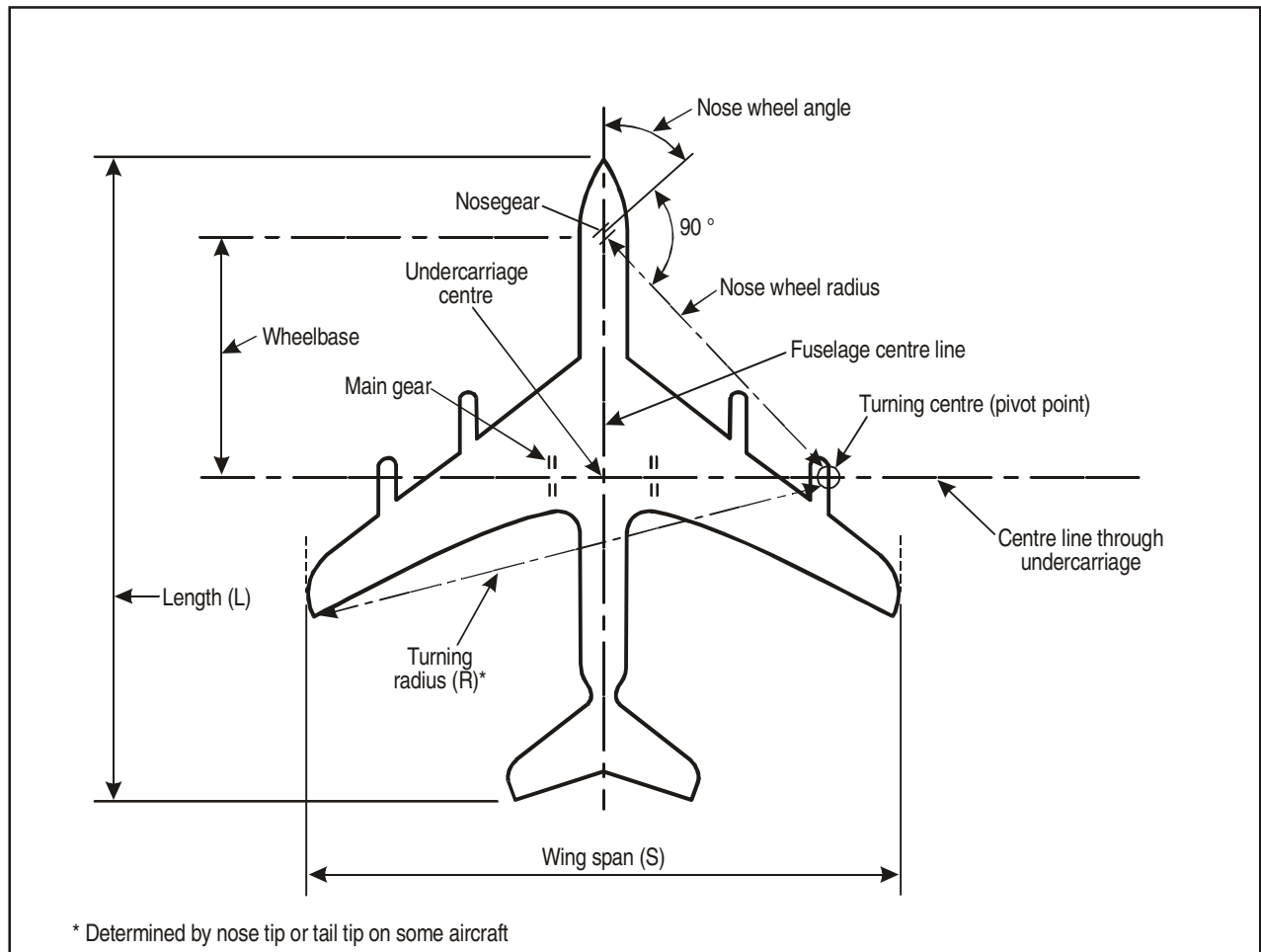

Figure 3-3. Dimensions for sizing aircraft stand spacing

the fuselage centre line depending upon the amount of nosewheel angle used in the turning manoeuvre. The values listed in Table 3-1 for the turning radii are derived from the nosewheel angles as listed. In most cases, these radii values are measured from the turning centre to the wing tip; however, on some aircraft, the turning radii are measured from the turning centre to the aircraft nose or to the horizontal stabilizers.

Traffic volumes

3.4.3 The number and size of aircraft stand positions needed for any type of apron can be determined from forecasts of aircraft movements at a given aerodrome. The forecast of apron activity must be broken down into an

appropriate demand planning period for the type of apron involved. The apron need not be designed for extraordinary peak periods of activity, but should be able to accommodate a reasonable peak activity period with a minimum amount of delay. For example, the number of passenger terminal aircraft stands should be adequate to handle the peak hour traffic of the average day of the peak month. The peak period for accumulation of cargo aircraft is longer than an hour and less than a day; therefore, the cargo apron should handle the average day's activity of the peak month. Other apron types should have enough parking spaces to handle their appropriate peak period of activity. In addition, planning for aprons should be broken into several phases to minimize the capital cost outlays needed. Apron areas should then be added as needed to accommodate the growth in demand.

Table 3-1. Selected aircraft dimensions

Aircraft type	Length (m)	Wing span (m)	Nose wheel angle	Turning radius (m)
A300B-B2	46.70	44.80	50°	38.80 ^a
A320-200	37.57	33.91	70°	21.91 ^c
A330/A340-200	59.42	60.30	65°	45.00 ^a
A330/A340-300	63.69	60.30	65°	45.60 ^a
B727-200	46.68	32.92	75°	25.00 ^c
B737-200	30.58	28.35	70°	18.70 ^a
B737-400	36.40	28.89	70°	21.50 ^c
B737-900	41.91	34.32	70°	24.70 ^c
B747	70.40	59.64	60°	50.90 ^a
B747-400	70.67	64.90	60°	53.10 ^a
B757-200	47.32	37.95	60°	30.00 ^a
B767-200	48.51	47.63	60°	36.00 ^a
B767-400 ER	51.92	61.37	60°	42.06 ^a
B777-200	63.73	60.93	64°	44.20 ^a
B777-300	73.86	73.08	64°	46.80 ^a
BAC 111-400	28.50	27.00	65°	21.30 ^a
DC8-61/63	57.12	43.41/45.2	70°	32.70 ^c
DC9-30	36.36	28.44	75°	20.40 ^c
DC9-40	38.28	28.44	75°	21.40 ^c
DC9-50	40.72	28.45	75°	22.50 ^c
MD82	45.02	32.85	75°	25.10 ^b
MD90-30	46.50	32.87	75°	26.60 ^b
DC10-10	55.55	47.35	65°	35.60 ^a
DC10-30	55.35	50.39	65°	37.30 ^a
DC10-40	55.54	50.39	65°	36.00 ^a
MD11	61.60	52.50	65°	39.40 ^a
L1011	54.15	47.34	60°	35.59 ^a

- a. To wing tip
- b. To nose
- c. To tail

Clearance requirements

3.4.4 An aircraft stand should provide the following minimum clearances between aircraft using the stand as well as between aircraft and adjacent buildings or other fixed objects.

Code letter	Clearance (m)
A	3.0
B	3.0
C	4.5
D	7.5
E	7.5
F	7.5

The clearances for code letters D, E and F can be reduced in the following locations (for aircraft using a taxi-in, push-out procedure only):

- between the terminal (including passenger loading bridges) and the nose of an aircraft; and
- over a portion of the stand provided with azimuth guidance by a visual docking guidance system.

These clearances may, at the discretion of the airport planners, be increased as needed to ensure safe operation on the apron. Location of aircraft stand taxilanes and apron taxiways should provide the following minimum separation distance between the centre line of these taxiways and an aircraft at the stand:

Code letter	Minimum separation distances	
	Aircraft stand taxilane centre line to object (m)	Apron taxiway centre line to object (m)
A	12.0	16.25
B	16.5	21.5
C	24.5	26.0
D	36.0	40.5
E	42.5	47.5
F	50.5	57.5

Types of aircraft stand ingress and egress

3.4.5 There are several methods used by an aircraft to enter and leave an aircraft stand: it may enter and leave under its own power; it may be towed in and towed out; it

may enter a position under its own power and be towed or pushed out. However, in considering apron size requirements, the various methods can be categorized as either self-manoeuving or tractor-assisted.

3.4.5.1 *Self-manoeuving*. This term denotes the procedure whereby an aircraft enters and leaves the aircraft stand under its own power, that is, without recourse to a tractor for any part of the manoeuvre. Figure 3-4 a), b) and c) shows the area required for aircraft manoeuvring into and out of an aircraft stand position for angled nose-in, angled nose-out and parallel parking configuration, respectively. The normal manoeuvre of taxiing into and out of an aircraft stand adjoining the terminal building or pier by nose-in or nose-out parking configuration involves a 180 degree turn as shown in Figure 3-4 a) and b). The radius of this turn and the geometry of the aircraft are among the factors which determine the aircraft stand spacing. Although this method of parking requires more pavement area than tractor-assisted methods, this is offset by a saving of the equipment and personnel required for the tractor operation. Thus these methods are common at airports with a relatively small volume of traffic. Figure 3-4 c) illustrates the stand spacing for self-manoeuving aircraft, which is contingent upon the angle at which the aircraft can comfortably manoeuvre into a stand position with other aircraft parked in the adjacent positions. While this parking configuration affords easiest manoeuvring for aircraft to taxi-in/out, it requires the largest apron area. In addition, due consideration should be given to the adverse effect of jet blast on servicing crew and equipment in neighbouring aircraft stands.

3.4.5.2 *Tractor-assisted*. This term applies to any method of ingress and egress that requires the use of a tractor and tow bar. Most of the world's busiest aerodromes use some variation of tractor-assisted methods. The most common procedure is the taxi-in, push-out method, but aircraft can also be towed in and out in other combinations. Use of tractors allows a much closer spacing of aircraft stands, reducing both the apron and terminal space required to accommodate a high volume of terminal aircraft parking. Figure 3-4 d) shows the area required for aircraft that taxi in and push out perpendicular to the terminal building. Clearly this procedure results in a more efficient use of apron space than the self-manoeuving procedure. This is a simple manoeuvre which can be done without creating excessive engine blast problems for apron personnel and equipment or the terminal building. The requirement for jet blast fences is also reduced or eliminated by adopting this procedure. Generally, some type of guidance system is provided for pilots to position aircraft accurately in the gate position. The departure manoeuvre is more complicated

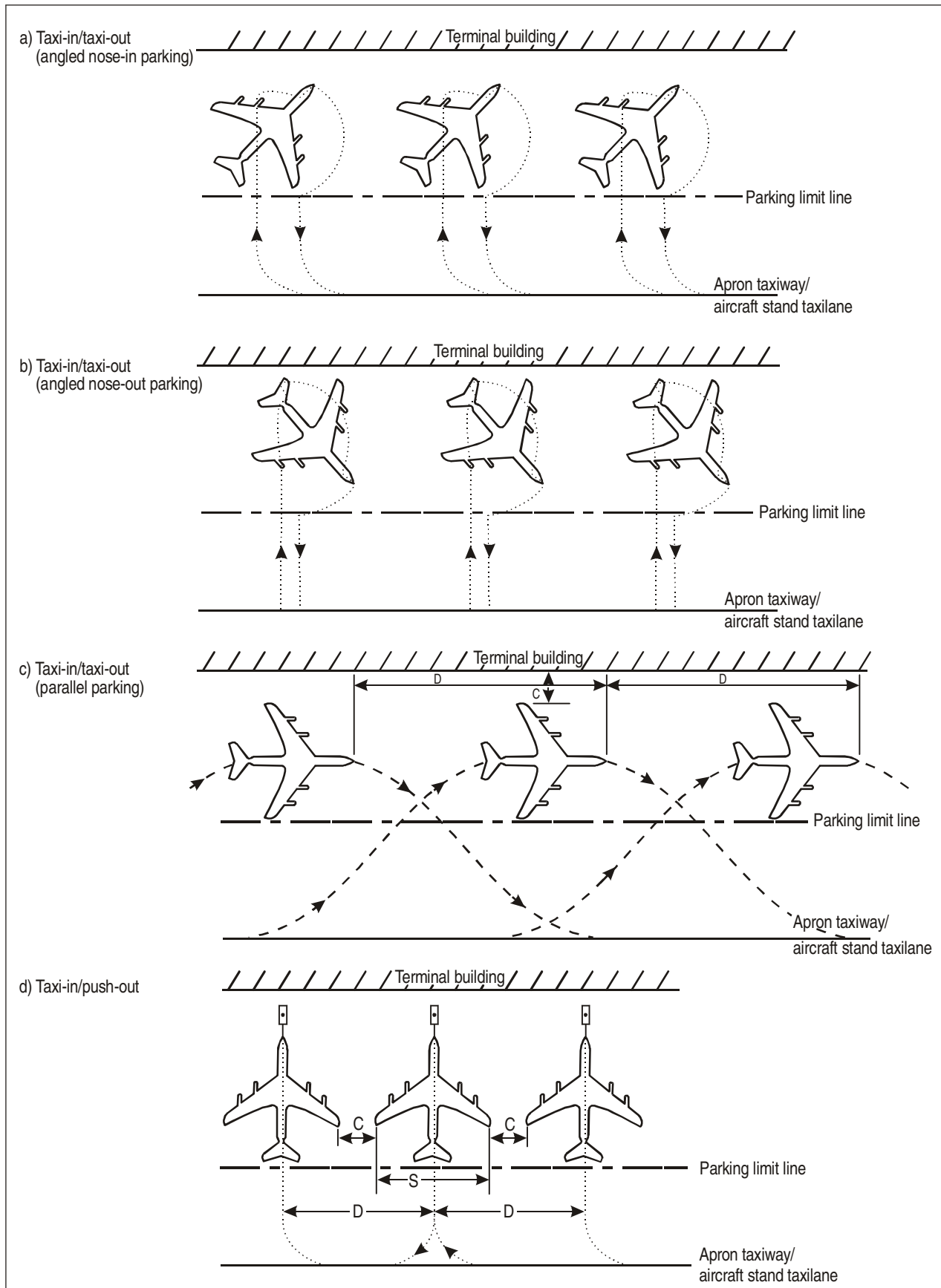

Figure 3-4. Clearance area required for terminal stand ingress and egress

and usually involves the aircraft being pushed backward by a tractor onto the taxiway while at the same time being turned up to 90 degrees. Normally the push-back operation is carried out without the engines started. It takes an average of 3 to 4 minutes from the beginning of the push-back until the tractor is disconnected and the aircraft is moving under its own power. The push-out operation requires skill and practice on the part of the driver to avoid over-castoring the nose wheel and, on slippery pavement, to keep the aircraft moving while simultaneously maintaining directional control because of the reduced traction.

3.4.5.3 *Stand spacing.* General formulae have been developed in a number of cases to calculate the required distance between aircraft stands. The simplest case is for aircraft that taxi in perpendicular to the terminal building and push out straight back. As shown in Figure 3-4 d), the minimum stand spacing (D) equals the wing span (S) plus the required clearance (C).

3.4.5.4 For other ingress and egress procedures, or for other parking angles, the geometry is more complex and a detailed analysis needs to be undertaken to determine stand spacings. Manufacturers' technical data should be consulted to determine the wing tip radii and operating characteristics for those aircraft likely to use these more complex manoeuvring techniques.

Aircraft ground servicing

3.4.6 Passenger aircraft services that are carried out during the time an aircraft is parked in a stand position include: galley, toilet and potable water service; baggage handling; fuelling; provision of air conditioning, oxygen, electrical power supply and starting air; and aircraft towing. Most of these functions have a vehicle and/or equipment associated with them or have some type of fixed installation established to conduct these services. Figure 3-5 shows a typical ground equipment service layout for a medium-sized aircraft. The area to the right of the aircraft nose forward of the wing is often used as a pre-positioned service area to store vehicles and equipment when the nose-in/push-out parking configuration is adopted.

Taxiways and service roads

General

3.4.7 The total area needed for an apron includes not only the individual aircraft stands, but also the area required for apron taxiways, aircraft stand taxilanes and

service roads needed to access the aircraft stands and provide necessary support services. Locations for these facilities will depend upon the terminal arrangement, runway locations and locations of off-apron services such as flight kitchens, fuel farms, etc.

Apron taxiways

3.4.8 Chapter 1 of this manual defines apron taxiways and aircraft stand taxilanes and their interaction with the aircraft stands. Aircraft stand taxilanes branch off of apron taxiways, which in turn are generally located on the edge of the apron pavement.

Service roads

3.4.9 Chapter 4 of this manual discusses the need for and location of service roads. The space needed for service roads must be considered during the overall apron planning. They are usually located either adjacent and parallel to the terminal building or on the air side of the aircraft stand parallel to the aircraft stand taxilane. The width required will depend upon the anticipated level of traffic and whether a one-way road system can be developed. If the service road is located adjacent to the terminal building, adequate clearance must be available under the loading bridges for the largest vehicles expected to use the road. If the service road is not adjacent to the terminal building, the difficulty of providing the necessary headroom under bridges is eliminated, but it introduces the problem of vehicle/aircraft conflict. Overall apron planning should also take into account manoeuvring and storage areas for ground equipment.

3.5 APRON GUIDANCE

In the *Aerodrome Design Manual* (Doc 9157), Part 4 — Visual Aids, the benefits of apron marking and lighting, as well as guidance on aircraft stands, are discussed. The objective of guidance on aircraft stands is to provide safe manoeuvring of aircraft on the aircraft stand and precise positioning of aircraft. Generally, during good visibility periods, the use of painted lines and, if necessary, marshalls will ensure safe, accurate movements. Flood-lighting on the apron area should be added for night operations and when visibility is poor, pavement centre line lighting should be provided. Visual docking guidance systems provide accurate guidance for an aircraft parking under its own power.

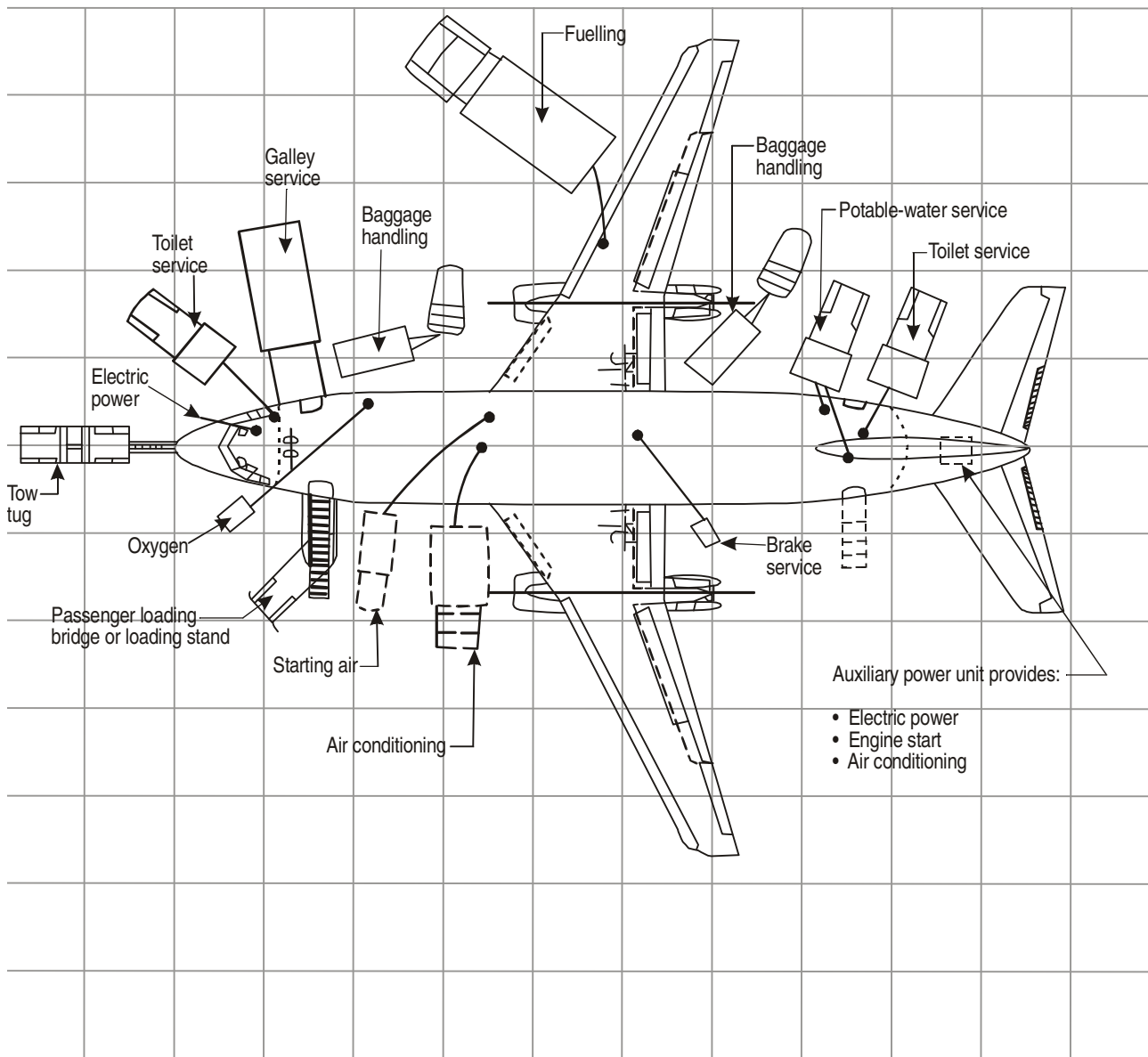

Figure 3-5. Typical ground equipment service layout

3.6 DE-ICING/ANTI-ICING FACILITIES

Location

3.6.1 Centralized de-icing/anti-icing facilities at or adjacent to terminals can be used if the demand for gate positions would not cause excessive delays, congestion and long waiting periods, and if the taxiing time from the terminal to the take-off runway would be less than the hold-over time of the fluid being used. An off-gate facility or a remote facility would permit better utilization of aircraft stands, compensate for changing weather conditions due to a shorter taxiing time and, consequently, ensure availability of a greater portion of the holdover time.

3.6.2 An off-gate facility along a taxiway may lead to queuing of aeroplanes and thus should have bypass taxiing capability as shown in Figure 3-6. An off-gate facility better permits collection of de-icing/anti-icing fluid run-off for its safe disposal than do aircraft stands. Where holding bays of adequate size and capacity are provided, these could be used for de-icing/anti-icing of aeroplanes provided all the above requirements are fulfilled. The taxiing routes for access to the de-icing/anti-icing pads should have minimum turns and intersections for expediting the movement of aeroplanes, while not affecting operational safety.

3.6.3 In order that de-icing/anti-icing facilities may operate efficiently, and to prevent the likelihood of runway incursions by service vehicles, vehicle service roads or staging areas may be required. Consideration should be given to ensure that the emergency response times of aerodrome rescue and fire fighting vehicles are not compromised. These service roads should take into account operational and safety factors (prevention of runway/taxiway incursions) as well as environmental factors (management of de-icing/anti-icing fluid run-off, etc.). Appropriate surface movement guidance and control (SMGC) signs, such as vehicle stop signs or road-holding position signs, may need to be installed.

Factors affecting the size of the de-icing/anti-icing facility

3.6.4 The size of a de-icing/anti-icing facility is dependent on the size of the aircraft, the number of aircraft requiring the treatment, the meteorological conditions, the type and capacity of the dispensing equipment used and the method of treatment. An indication of the total size of the facility could be estimated from the number of aircraft requiring treatment at a given time. The transit time of de-icing/anti-icing vehicles between the refilling/storage area and the de-icing/anti-icing facilities should also be taken into account.

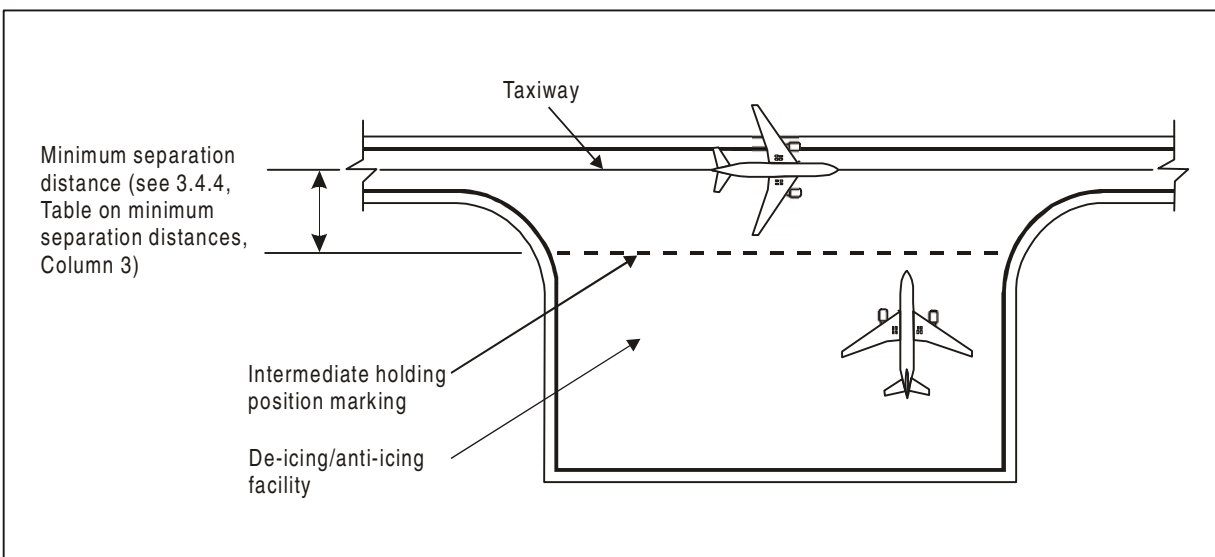

Figure 3-6. Minimum separation distance on a de-icing/anti-icing facility

Factors affecting the number of de-icing/anti-icing pads

3.6.5 The number of pads required is dependent on:

- a) the meteorological conditions — at airports where wet snow or freezing rain conditions are more prevalent, a greater number of de-icing/anti-icing pads are recommended to be provided to prevent unacceptable delays;
- b) the type of aeroplanes to be treated — narrow-body aeroplanes require less processing time than do wide-body aeroplanes. Aeroplanes with fuselage-mounted engines require more processing time than those with wing-mounted engines;
- c) the method of application of de-icing/anti-icing fluid — the method may be either the one-step or two-step de-icing/anti-icing procedure. As the latter procedure results in longer occupancy times, the number of de-icing/anti-icing pads required should be based on the two-step procedure for flexibility and also to ensure that the maximum aeroplane departure flow rates are not adversely affected; and
- d) the type and capacity of the dispensing equipment used — mobile de-icing/anti-icing equipment with small tank capacities and requiring extended fluid heating times can increase application times and adversely affect the aeroplane departure flow rates; and
- e) the departure flow rates — the number of aeroplanes to be treated should match the number

of take-off operations that can be cleared to minimize possible delays and airport congestion.

Environmental considerations

3.6.6 The size of a de-icing/anti-icing pad should be equal to the parking area required for the most demanding aeroplane and should also provide a 3.8 m vehicle movement area all round. Where more than one de-icing/anti-icing pad is provided, there should be no overlap of the vehicle movement area required exclusively for each pad. Furthermore, while planning the total size of a de-icing/anti-icing facility, the minimum clearances specified in Chapter 3 of Annex 14, Volume I should be taken into account.

3.6.7 Excess de-icing/anti-icing fluid running off an aeroplane poses the risk of contamination of ground water if allowed to mix with other surface run-off. Furthermore, the fluids also have an adverse effect on the pavement surface friction characteristics. Therefore, it is imperative that an optimum quantity be used. Nevertheless, all excess fluids must be properly collected to prevent ground water contamination. All surface run-off from such areas must be adequately treated before discharging into storm water drains.

3.6.8 One approach would be to collect all apron surface run-off at a collection point where the contaminated run-off could be suitably treated before discharging it to the storm water drains. Grooving of the pavement would facilitate in the collection of all excess de-icing/anti-icing fluids. In case of remote de-icing/anti-icing pads, the collection and handling of the excess fluid is relatively easier than at aircraft stands.

Chapter 4

SEGREGATION OF TRAFFIC ON THE MOVEMENT AREA

4.1 NEED FOR TRAFFIC SEGREGATION

4.1.1 The potential for aircraft and ground vehicle interactions exists on the runways, taxiways and aprons that make up the aircraft movement area. The number of interactions can be minimized, however, in the planning phase of the aerodrome facility by segregating the air and ground traffic. Properly segregated traffic will minimize the possibility of aircraft and ground vehicle collisions and maximize the efficiency of aircraft movements. Those interactions that are necessary should be planned for predesignated areas using established procedures.

4.1.2 There is a need for some ground vehicles to operate on the movement area for the purposes of aircraft servicing, aerodrome maintenance and construction work, and emergency operations. However, because of the different physical characteristics of aerodromes, no specific design criteria can be established to promote segregation of traffic. There are, however, a number of measures that may be taken to lessen the amount of mixing of aircraft and ground vehicles.

4.2 ACTIVITIES CAUSING A MIX OF AIRCRAFT AND GROUND VEHICLES

4.2.1 The majority of interactions that can occur between aircraft and ground vehicles take place on apron areas. The following are some aircraft servicing operations performed on aprons that may involve attendance of ground vehicles and that should be taken into account when planning segregation of traffic on aprons:

- a) passenger unloading/loading;
- b) baggage unloading/loading;
- c) cargo and/or mail unloading/loading;

- d) galley service;
- e) sanitation service;
- f) fuelling service;
- g) provision of compressed air for engine starting;
- h) aircraft maintenance; and
- i) electric power and air conditioning (if not provided by aircraft auxiliary power units).

In addition, provision should be made for emergency and security vehicles on the apron areas.

4.2.2 Ground vehicle activities that occur on movement areas outside of the aprons include the following:

- a) *Emergency operations.* Rescue and fire fighting equipment, which may be required at any point on the aerodrome or runway approach areas;
- b) *Security operations.* Small vehicles used for the patrol of fence lines and restricted areas;
- c) *Aerodrome maintenance and construction.* Repair of pavements, navigation aids and lighting, grass mowing, snow/ice removal operations, etc.

4.3 METHODS TO ACHIEVE SEGREGATION

4.3.1 Several general concepts for achieving segregation of traffic are presented in the following paragraphs. For apron areas in particular, the degree of segregation which can be achieved depends largely on the available space. The greater the amount of space available for a given number of aircraft stands, the easier it is to segregate types

of traffic. Normally, the need for economy is such that aprons are rarely designed with excess area and, in any case, air traffic growth generally absorbs any designed spare apron area. The degree of segregation necessary is dependent on the dimensions and other characteristics of aircraft (e.g. wing span, manoeuvrability and jet blast) and the nature of the ground vehicles. In addition, when planning an aerodrome, aircraft operators should be consulted to determine their anticipated ground vehicle movement requirements.

Exclusion

4.3.2 Although the design of aerodrome facilities can ease considerably the problem of mixing of aircraft with ground vehicles, it is nevertheless most important that aircraft operators be conscious of the need to keep the volume of their ground traffic to a minimum. All ground vehicles whose function does not require them to be on the movement area should be excluded. This practice is also in accord with basic aerodrome security measures. Land side road systems should be designed so that public vehicles have access to all public areas of an aerodrome without travelling on the movement area. Measures should also be taken to prevent unauthorized access of public vehicles to the movement area. This requires the provision of fences, gates and other security systems needed to strictly control access.

Service roads for ground vehicles

4.3.3 Air side service roads for ground vehicles can eliminate or lessen to a great extent the necessity for the use of runways and taxiways by ground vehicles. Such roads should be planned so that at least the critical sections of the movement area for traffic congestion can be bypassed by ground vehicular traffic. For example, these roads may be used as aerodrome perimeter service roads providing access to navigation aids, as temporary roads for construction vehicles or as air side roads between terminal buildings and aprons for the passage of airline vehicles, baggage trains, etc. For terminals with passenger loading bridges, air side roads may (for some designs) pass beneath the immovable part of the loading bridge. Figure 4-1 shows examples of air side service roads used on aprons.

4.3.4 Some general considerations in the planning of roads are described as follows:

- a) Every effort should be made to plan air side service roads so that they do not cross runways and

taxiways. At high traffic aerodromes, road tunnels beneath runways and taxiways should be considered at major intersections in order to avoid such crossings;

- b) The planning of the aerodrome road layout should take into account the need to provide emergency access roads for use by rescue and fire fighting vehicles to various areas on the aerodrome and in particular to the approach areas up to 1 000 m from the threshold, or at least within the aerodrome boundary;
- c) Service roads to navigation aids should be planned in such a manner as to present minimal interference to the function of the aids. If it is necessary for an access road to cross an approach area, the road should be located so that vehicles travelling on it are not obstacles to aircraft operations; and
- d) The air side service road system must be designed to account for local security measures. Access points to the system will thus need to be restricted. Should ground vehicle movements affect surface movement of aircraft on runways and taxiways, it will be required that the ground vehicle movements be coordinated by the appropriate aerodrome control. Control is normally exercised by means of two-way radio communication, although visual signals, such as signal lamps, are adequate when traffic at the aerodrome is light. Signs or signals may also be employed to aid control at intersections.

Fixed servicing installations

4.3.5 Many apron service vehicles can be eliminated with the provision of fixed servicing installations set either within the apron or within the terminal buildings adjacent to the aircraft stands. For example, the provision of hydrant fuelling systems, compressed air outlets, static power supplies, drainage outlets, drinking water hydrants, air conditioning outlets and telephone outlets close to aircraft stands would considerably reduce the equipment and vehicles required for aircraft servicing. Loading bridges for passenger loading and unloading can also be thought of as a form of fixed servicing installation as they eliminate the need for passenger loading equipment and the need for passengers to travel over the apron (either by walking or in a passenger transport vehicle). Furthermore, loading bridges generally lend themselves to the provision of fixtures for aircraft servicing operations. Some of the

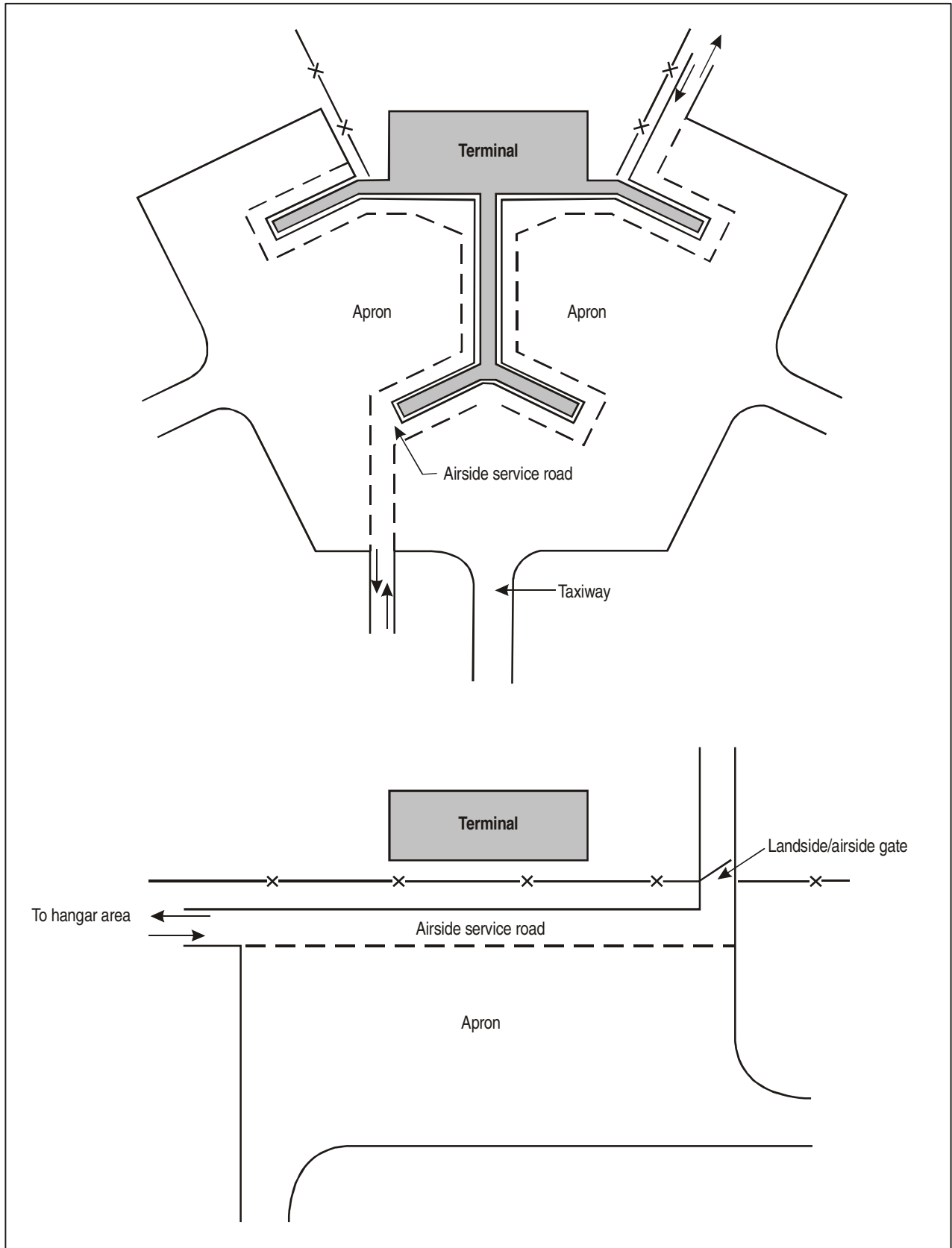

Figure 4-1. Examples of airside service roads

disadvantages of fixed servicing installations are high initial costs and limited flexibility for different aircraft types. However, if in the planning stage careful consideration is given to the location and number of these facilities, the required flexibility can be achieved. In addition, the different power supply requirements of present-day aircraft complicate the provision of static power supplies; however, the trend in aircraft design is towards greater standardization of electrical requirements. See the *Airport Planning Manual* (Doc 9184), Part 1 — Master Planning, for planning considerations regarding fixed servicing installations.

Markings

4.3.6 Paint markings should be used to facilitate the segregation of traffic on aprons. Markings can be used to provide guidance to pilots in manoeuvring their aircraft safely and expeditiously on aprons. Other markings are used to designate safety limits for placement of equipment on aprons, e.g. wing tip clearance lines and other markings used to delineate access routes for ground vehicles, passengers or personnel across the apron. There should be a colour change between lines to distinguish one from another.

Appendix 1

FILLET DESIGN

1. TERMINOLOGY AND SYMBOLS

1.1 General

A description of the terms and symbols used in this appendix is given below. Throughout this appendix it is assumed that the aircraft is taxiing on a horizontal pavement.

1.2 Terms related to the aircraft (see Figure A1-1)

Centre line through main undercarriage. Line from the turning centre perpendicular to the aircraft longitudinal axis.

Datum length (d). Distance between aircraft datum point and centre line through undercarriage.

Datum point of aircraft (S). Point on longitudinal axis of aircraft which follows the guideline on the ground. The datum point is located vertically beneath the cockpit of the aircraft.

Main undercarriage centre (U). Point of intersection of longitudinal aircraft axis and centre line through main undercarriage.

Nose wheel steering angle. Angle formed by the longitudinal axis of aircraft and the direction of the nose wheel.

Steering angle (β). Angle formed by the tangent to the guideline and the longitudinal axis of aircraft.

Track of the main undercarriage (T). Distance between the outer main wheels of aircraft including the width of the wheels.

Turning centre (P). Centre of turn of aircraft at any time.

1.3 Terms related to taxiway and fillet design (see Figure A1-2)

Deviation of main undercarriage (λ). Distance between main undercarriage centre (U) and the guideline measured at right angles to the latter.

Guideline. Line applied to the pavement by means of markings and/or lights which the aircraft datum point must follow while taxiing.

Guideline centre (O). Centre of curvature of guideline at point S .

1.4 Glossary of symbols

The following symbols are used when describing the path of the main undercarriage centre and the design of the fillets (see Figures A1-1 and A1-2).

d = aircraft datum length

M = minimum clearance distance between outer wheels of main undercarriage leg and edge of pavement

O = centre of curvature of guideline at point S

P = turning centre

r = radius of fillet arc

R = radius of curvature of guideline at point S

S = datum point of aircraft

T = track of the main undercarriage

U = main undercarriage centre

α = angle between the radial line OU and the tangent to the path of the main undercarriage centre at U

β = steering angle

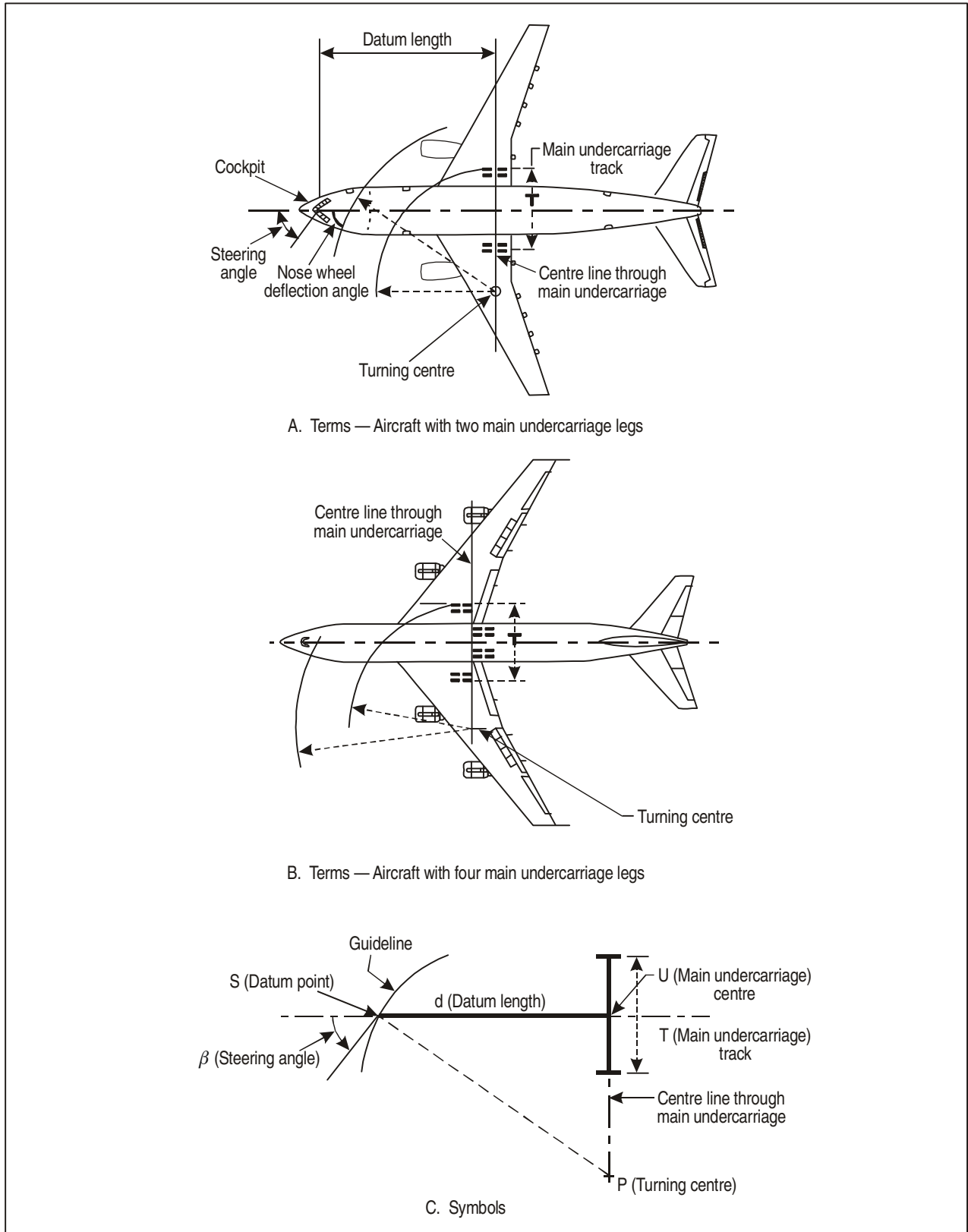

Figure A1-1. Terms and symbols related to aircraft

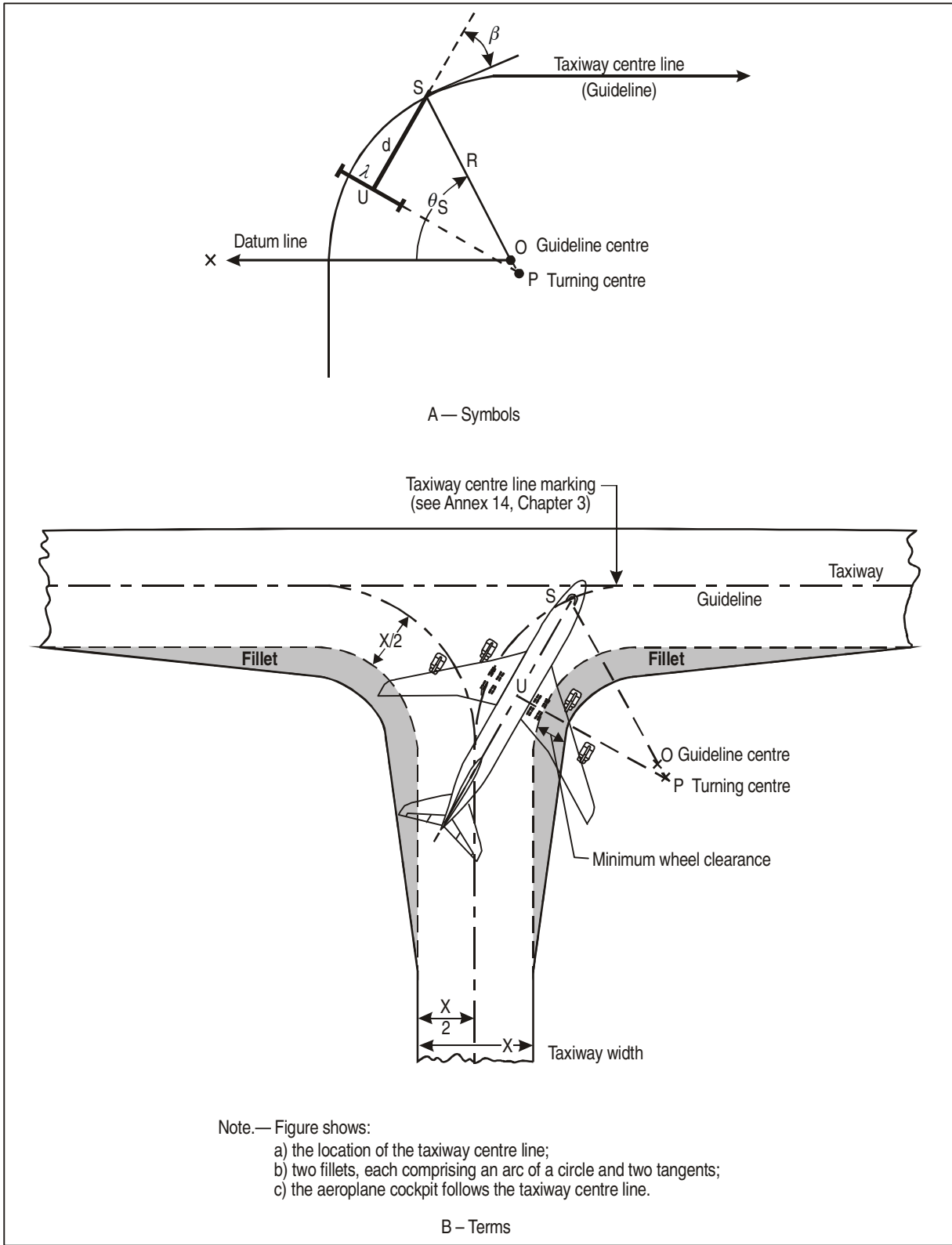

Figure A1-2. Terms and symbols related to taxiway and fillet design

λ = main undercarriage deviation

ρ and θ = polar coordinates of a point [(S) or (U), as applicable]

2. DETERMINATION OF THE PATH FOLLOWED BY THE MAIN UNDERCARRIAGE OF A TAXIING AIRCRAFT

2.1 Determination of the path by calculation

General

2.1.1 In general, the junction or intersection of taxiways with runways, aprons and other taxiways is achieved by means of an arc of a circle (Figure A1-2B). The calculations below are therefore restricted to the solutions based on this assumption. Nevertheless, the following calculation is more general than the one strictly necessary for the study of fillets. It also applies to movement of an aircraft leaving its parking position on an apron or manoeuvring on a holding bay.

Datum point (S) follows an arc of a circle

Locus of main undercarriage centre (U)

2.1.2 Because of the simplifying assumption above, the datum point of the aircraft (S) follows an arc of a circle with centre O and radius R during the turn. In order to describe the movement of a taxiing aircraft, it is necessary to have a reference coordinate system. Let OX be the datum line, ρ and θ_U be the polar coordinates of U (see Figure A1-3). During movement, the straight line US remains a tangent to the path of the point U at U. This condition produces the differential equation for the locus of U:

$$\tan \alpha = \frac{\rho(d\theta_U)}{(d\rho)} \tag{1}$$

ρ can be expressed as a function of d , R and α as follows:

$$\rho = d \times \cos \alpha \pm \sqrt{(d^2 \times \cos^2 \alpha - d^2 + R^2)} \tag{2}$$

Note.— The sign must be positive (+) if $\alpha > \pi/2$ and negative (-) if $\alpha < \pi/2$.

Separating the variables enables the differential equation (1) to be rewritten as follows:

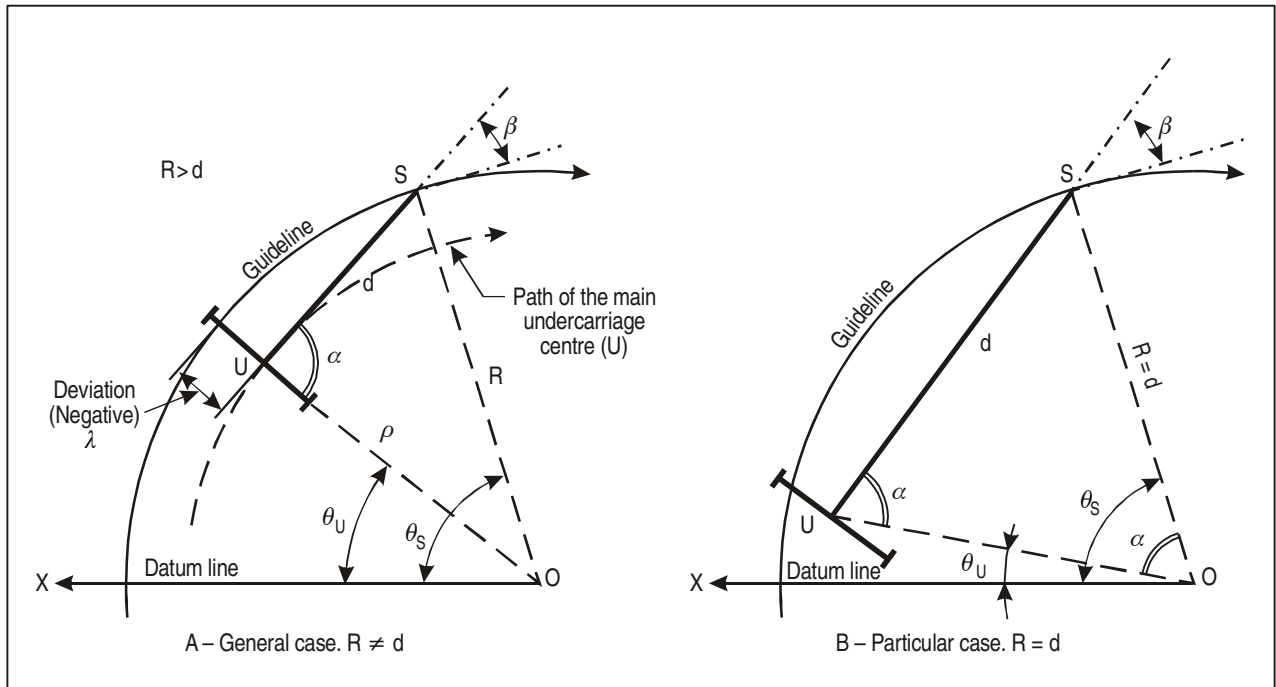

Figure A1-3. Study of the path of the main undercarriage

$$d\theta_U = \frac{d \times \tan \alpha \times \sin \alpha}{\sqrt{[R^2 + d^2 \times (\cos^2 \alpha - 1)]}} \times (d\alpha) \quad (3)$$

Integrating formula (3) produces a biunivocal relationship between θ_U and α under the initial given conditions.

$$\theta_U - \theta_O = \int_{\alpha_o}^{\alpha} \frac{\tan \alpha \times \sin \alpha}{\sqrt{\left[\left(\frac{R^2}{d}\right) + \cos^2 \alpha - 1\right]}} \times (d\alpha) \quad (4)$$

2.1.3 *Special case: $R = d$.* Integration is only easy in the particular case when $R = d$ (see Figure A1-3B). Indeed, if R , the radius of curvature of the guideline, is equal to d , then the datum length of the aircraft would be:

$$\begin{aligned} \theta_U - \theta_S &= \int_{\alpha_o}^{\alpha} \frac{\tan \alpha \times \sin \alpha}{\cos \alpha} \times (d\alpha) \\ &= \int_{\alpha_o}^{\alpha} \tan^2 \alpha \times (d\alpha) = [\tan \alpha - \alpha]_{\alpha_o}^{\alpha} \end{aligned}$$

and by assuming the initial conditions $\theta_o = O$, $\alpha_o = O$ and $\rho_o = 2d$

$$\theta_U = \tan \alpha - \alpha \quad (5)$$

the angles being expressed in radians. The polar angle of the datum point (S) is then:

$$\theta_S = \tan \alpha \quad (6)$$

The corresponding steering angle is:

$$\beta = 2\alpha - \pi/2 \quad (7)$$

and the deviation of the undercarriage can be calculated by means of the formula:

$$\lambda = d(2 \cos \alpha - 1) \quad (8)$$

The curves for this particular case are plotted on Figure A1-4. The use is explained in 2.2.

2.1.4 *General case: $R \neq d$.* If R is not equal to d , equation (4) can only be evaluated by solving an elliptical integral. Such an evaluation requires appreciable calculations which cannot be justified for the purpose of fillet design. The alternative method using an approximation described in 2.1.2.4 avoids excessively laborious calculation and still provides a fillet design of adequate accuracy.

2.1.5 Knowledge of the steering angle (β) at any point of the path of the aircraft datum point (S) easily enables the locus of the main undercarriage centre (U) to be found and hence the path of the undercarriage during the turn to be derived. Let now O be the guideline centre and R its radius. Assuming that the steering angle (β) remains unchanged, the instantaneous centre of rotation of the aircraft at a given time is P and not O . Consequently, during the short taxi run, the datum point would have departed from the guideline and covered an arc subtending a small angle equal to:

$$\frac{R}{d} \sin \beta \times (d\theta_S) \quad (9)$$

where

d is the datum length of the aircraft;

R and θ_S are the polar coordinates of the point S with reference to the datum line OX .

As a first approximation it can be accepted that, when the datum point (S) follows the guideline, the variation in the steering angle is:

$$d\beta = \left(1 - \frac{R}{d} \sin \beta\right) \times (d\theta_S) \quad (10)$$

This condition produces the following biunivocal relationship between θ_S and β under the given initial conditions:

$$\theta_S - \theta_o = \int_{\beta_o}^{\beta} \frac{d}{d - R \sin \beta} \times (d\beta) \quad (11)$$

2.1.6 Integration of this equation prompts the assumption that $R/d = X$ and consideration of the one case when $R > d$, $K = \sqrt{X^2 - 1}$. Solving the equation with respect to $\beta/2$ and applying the initial conditions $\theta_o = O$, $\beta_o = O$, it can be found that:

$$\theta_S = \frac{1}{K} \log \frac{1 + (K - X) \tan \frac{\beta}{2}}{1 - (K + X) \tan \frac{\beta}{2}} \quad (12)$$

which, expressed in terms of parameters R and d , gives:

$$\begin{aligned} \theta_S &= \frac{d}{\sqrt{R^2 - d^2}} \\ &\times \log \left[\frac{d + [\sqrt{R^2 - d^2} - R] \tan \frac{\beta}{2}}{d - [\sqrt{R^2 - d^2} + R] \tan \frac{\beta}{2}} \right] \end{aligned} \quad (13)$$

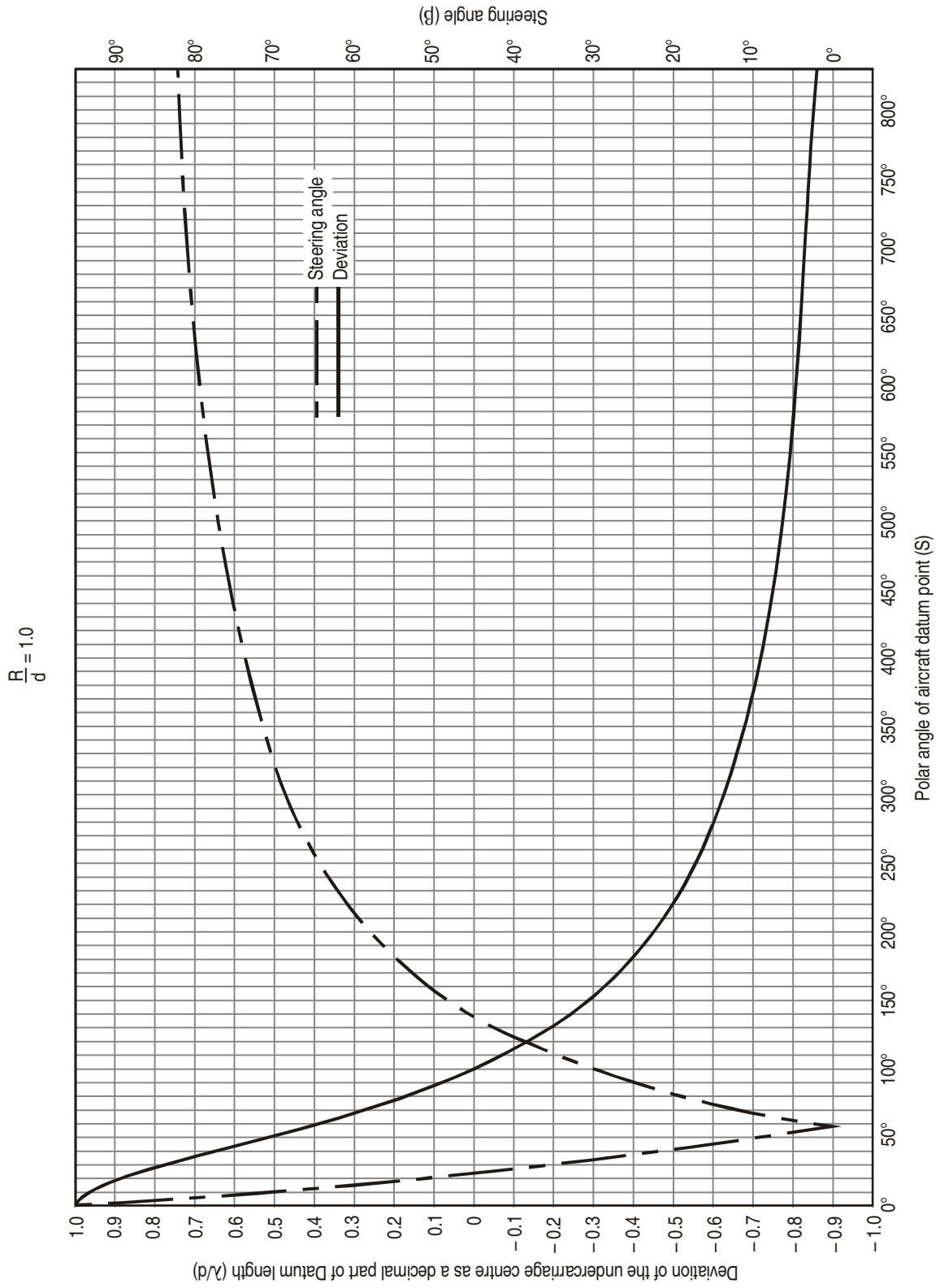

Figure A1-4. Steering angle and deviations of the undercarriage when $R = d$

in which θ_s is expressed in radians and natural logarithms are used. This allows $\tan \beta/2$ to be obtained as a function of θ_s . Using the above notations it can be found:

$$\tan \frac{\beta}{2} = \frac{1 - e^{K\theta}}{X - K - X \times e^{K\theta} - K \times e^{K\theta}} \quad (14)$$

assuming that $R > d$.

Deviation of main undercarriage centre (λ)

2.1.7 On an apron, depending on the initial conditions, the deviation of U can be inside or outside the guideline followed by S (see Figure A1-5). On a runway or a taxiway when the aircraft datum point (S) enters the turn, the initial deviation of the main undercarriage centre is outside the arc of circle and during the turn it gradually tracks in. At any time therefore (see Figure A1-3):

$$\begin{aligned} \Lambda_{USO} &= \frac{\pi}{2} \pm \beta; \text{ and} \\ (R + \lambda)^2 &= R^2 + d^2 - 2dR \times \cos \left(\frac{\pi}{2} \pm \beta \right) \end{aligned} \quad (15)$$

The solutions of this equation produce the following deviation values:

inside the arc

$$\lambda = \sqrt{R^2 + d^2 - 2dR \sin \beta} - R; \text{ and}$$

outside the arc

$$\lambda = \sqrt{R^2 + d^2 + 2dR \sin \beta} - R; \text{ or}$$

if the deviation value is expressed as a percentage of the aircraft datum length:

$$\frac{\lambda}{d} = \sqrt{1 + X^2 \pm 2X \sin \beta} - X \quad (16)$$

where the positive sign must be used in case of deviation outside the arc of circle and the negative sign in case of deviation inside the arc of circle.

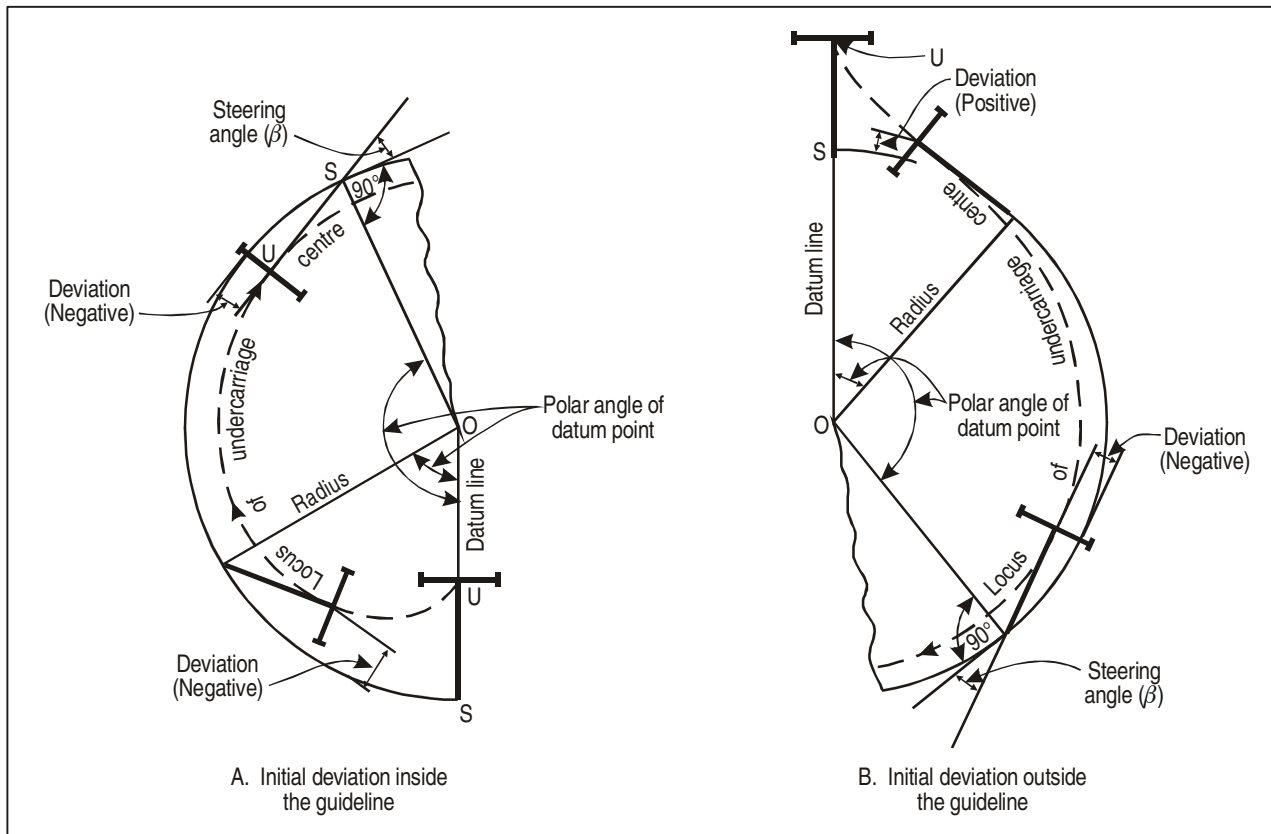

Figure A1-5. Deviation of main undercarriage centre when the datum point follows an arc of circle

Datum point (S) follows a straight line

Locus of main undercarriage centre (U)

2.1.8 Having completed the curve, the datum point (S) follows a straight path along the taxiway centre line. The steering angle is progressively reduced and the main undercarriage centre describes a tractrix (see Figure A1-6). As a result,

$$\log \tan \frac{\beta}{2} = \log \tan \frac{\beta_{\max}}{2} - \frac{F}{d} \quad (17)$$

enables the steering angle to be calculated when the datum point (S) has travelled through a distance F along the straight taxiway centre line.

Deviation of main undercarriage centre (λ)

2.1.9 When the datum point (S) has covered the distance F along a straight segment of the guideline (see Figure A1-6) the steering angle (β) has assumed the value calculated in 2.1.3.1 and the deviation of the main undercarriage centre (U) is given by:

$$\frac{\lambda}{d} = \sin \beta \quad (18)$$

Results of the above calculations

2.1.10 The calculations described above can be used to find the locus of the main undercarriage centre of an aircraft during a turn. Moreover, they permit plotting of graphs similar to those shown in Figures A1-7, A1-9, A1-11, A1-14, A1-15, A1-16 and A1-17. The use of these graphs as an aid for fillet design is described in 3.

2.2 Determination of the path with the aid of graphs

General

2.2.1 This method¹ involves determining several successive positions of the aircraft using the following parameters:

β = steering angle; and

λ = deviation of main undercarriage

1. The graphs on Figures A1-7, A1-9 and Table A1-1 were prepared by Australia. The graphs can also be used for an aircraft manoeuvring on a holding bay or leaving an aircraft stand.

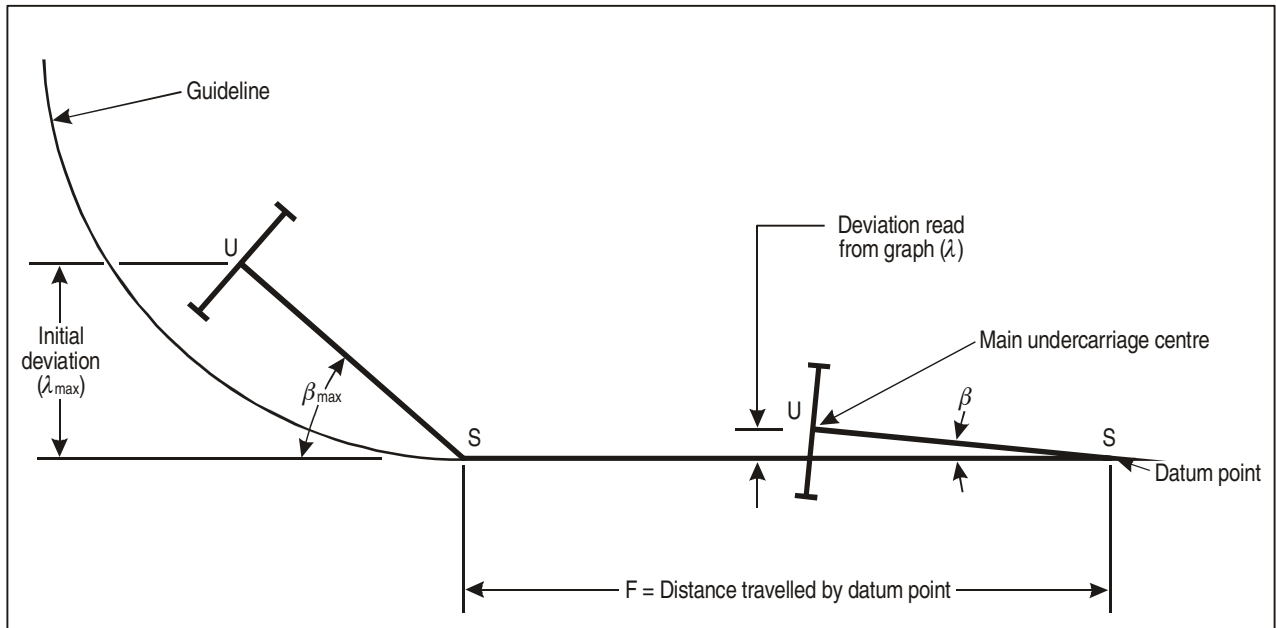

Figure A1-6. Deviation of the main undercarriage centre when the datum point follows a straight line

and plotting the locus of the main undercarriage centre point by point during the manoeuvre of the aircraft. The graph obtained must be checked to verify that the steering angle during the turn remains within the permissible limits for the nose wheel of the aircraft in question.

Datum point (S) follows a straight line

Locus of the main undercarriage centre (U)

2.2.2 Figure A1-7 gives the deviation of the main undercarriage centre from a straight line knowing the initial deviation from that line and the distance travelled along it by the datum point.

Example

An aircraft of datum length 18 m follows a straight line for a distance of 40 m, as shown in Figure A1-8.

- Step 1. Scale the initial deviation as shown. Initial deviation = 12 m = 66.7% of the datum length.
- Step 2. The distance of 40 m travelled by the datum point is 216.7% of the datum length.
- Step 3. The deviation of the undercarriage centre after the datum point has travelled along the straight line is 8.75% of the datum length as shown on Figure A1-7. The deviation in this position is 1.60 m.

Datum point (S) follows an arc of a circle

Locus of the main undercarriage centre (U)

2.2.3 The graphs on Figure A1-9 have been drawn for selected values of the ratio:

$$\frac{\text{Radius of the arc of a circle}}{\text{Aircraft datum length}} = \frac{R}{d}$$

The graphs have been prepared for R/d values ranging between 0.5 and 10.0. These values are marked above every graph which shows:

- a) the deviation of the main undercarriage centre;
- b) the steering angle (dashed curve)

as a function of the values assumed by the polar angle of the aircraft datum point.

Example

An aircraft of datum length 18 m follows an arc of circle of radius 27 m, as shown in Figure A1-10.

- Step 1. Scale the deviation of the main undercarriage centre at the point where the datum point commenced to travel around the curve.

Deviation = 12.15 m = +0.675 of the datum length

- Step 2. Calculate $\frac{R}{d} = \frac{27}{18} = 1.5$

- Step 3. From Figure A1-11 for $R/d = 1.5$, read the polar angle of the datum point corresponding to the deviation obtained in step 1.

Deviation = +0.675
Polar angle of datum point = 27.5°.

- Step 4. Using the polar angle of datum point obtained in step 3, plot the datum line as shown in the diagram.

- Step 5. Select suitable polar angles of datum point as shown in the diagram and read the corresponding deviations from the same Figure A1-11.

<i>Polar angle of aircraft datum point</i>	<i>Deviation of main undercarriage centre</i>
--	---

94°	0.125 of the datum length = 2.25 m
-----	------------------------------------

142°	0.285 of the datum length = 5.15 m
------	------------------------------------

- Step 6. From the deviations obtained in step 5, plot the locus of the main undercarriage centre as shown in the diagram.

- Step 7. Steering angles can be obtained for any selected polar angle of the datum point by reading the values shown with a dotted line on the graph.

e.g. Polar angle of datum point = 142°
Steering angle = 36.2°

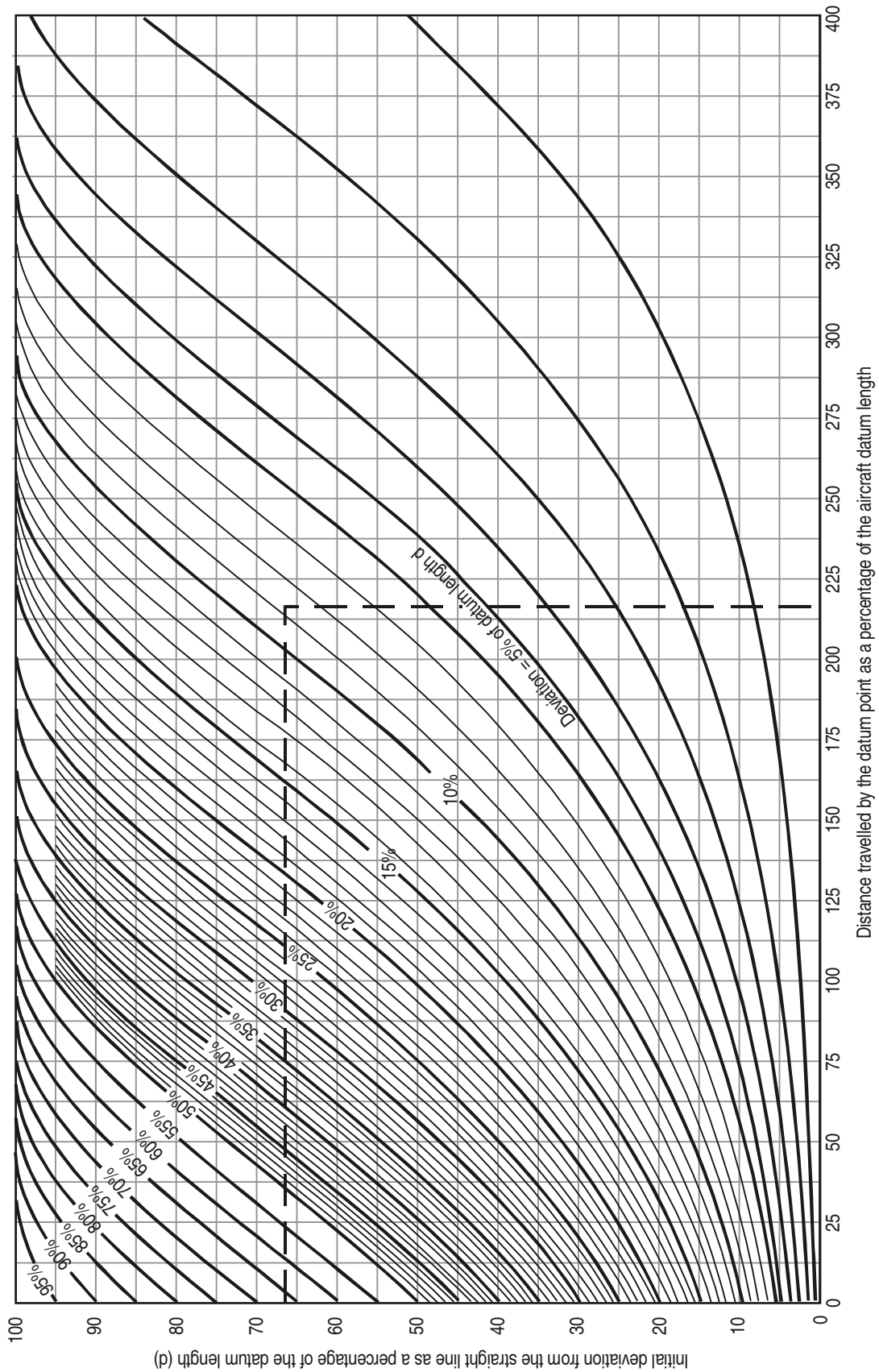

Figure A1-7. Steering angle (β) and deviations (λ) of the main undercarriage centre when the datum point (S) follows a straight line

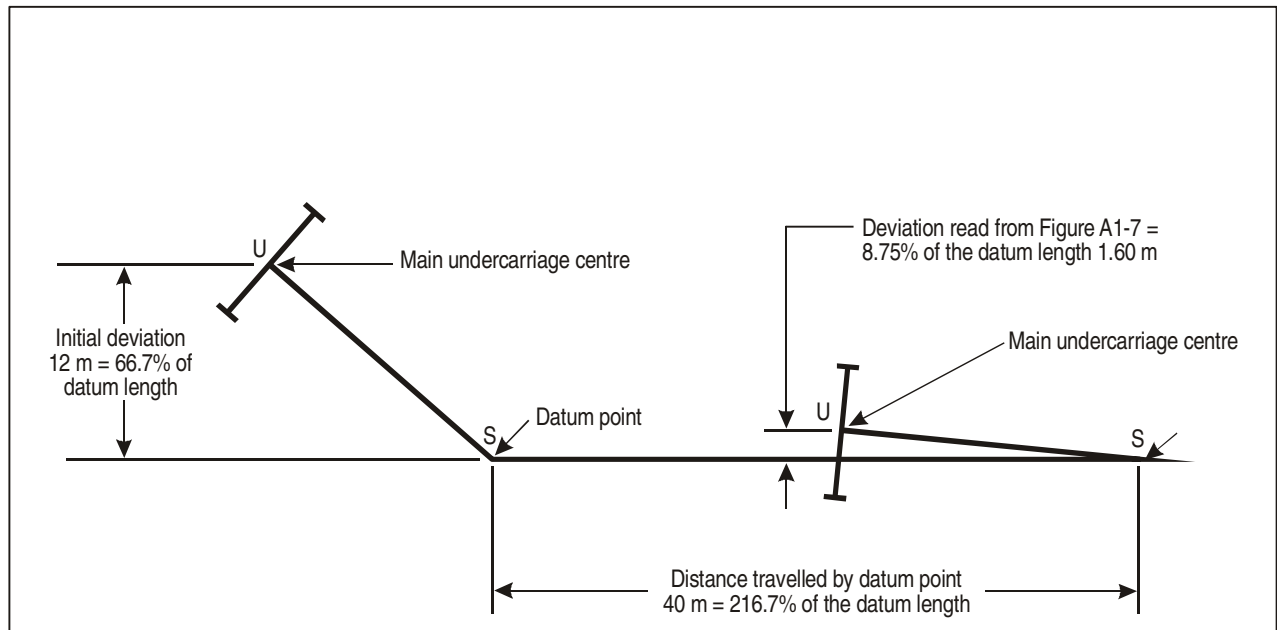

Figure A1-8. Example of the deviation of the main undercarriage centre (U) when the datum point follows a straight line

Note.— In the graphs, a dotted line for the steering angle corresponds to a solid line representing the deviation of the main undercarriage. When the deviation of the main undercarriage is indicated by a dot-dash line, the steering angle should be read on the corresponding dot-dash line.

Nose wheel deflection angles (β)

2.2.4 Knowing the ratio X of the datum length to the aircraft wheel base (distance between the nose wheel and the centre line through the main undercarriage), the nose wheel deflection angles can be read from Table A1-1 for any given steering angle.

Example

An aircraft of datum length of 55 m and wheel base of 36.6 m develops a steering angle of 77.778° after negotiating an arc of a circle.

Step 1. Calculate the ratio “ X ”.

$$X = \frac{55}{36.6} = 1.5$$

Step 2. In Table A1-1 select the column for $X = 1.5$.

Step 3. Read from Table A1-1 the nose wheel deflection angle corresponding to the steering angle = 77.778° , i.e. nose wheel deflection angle = 72° .

Step 4. A check should then be made to ensure that the maximum nose wheel deflection angle of the aircraft has not been exceeded. If this is the case, a greater value should be chosen for the radius of the guideline (applying the process described in 3.2.4 when $R < d$) and the fillet will be larger, although in some cases, it would be preferable to redesign the taxiway itself, adopting a greater radius for the curve of the centre line.

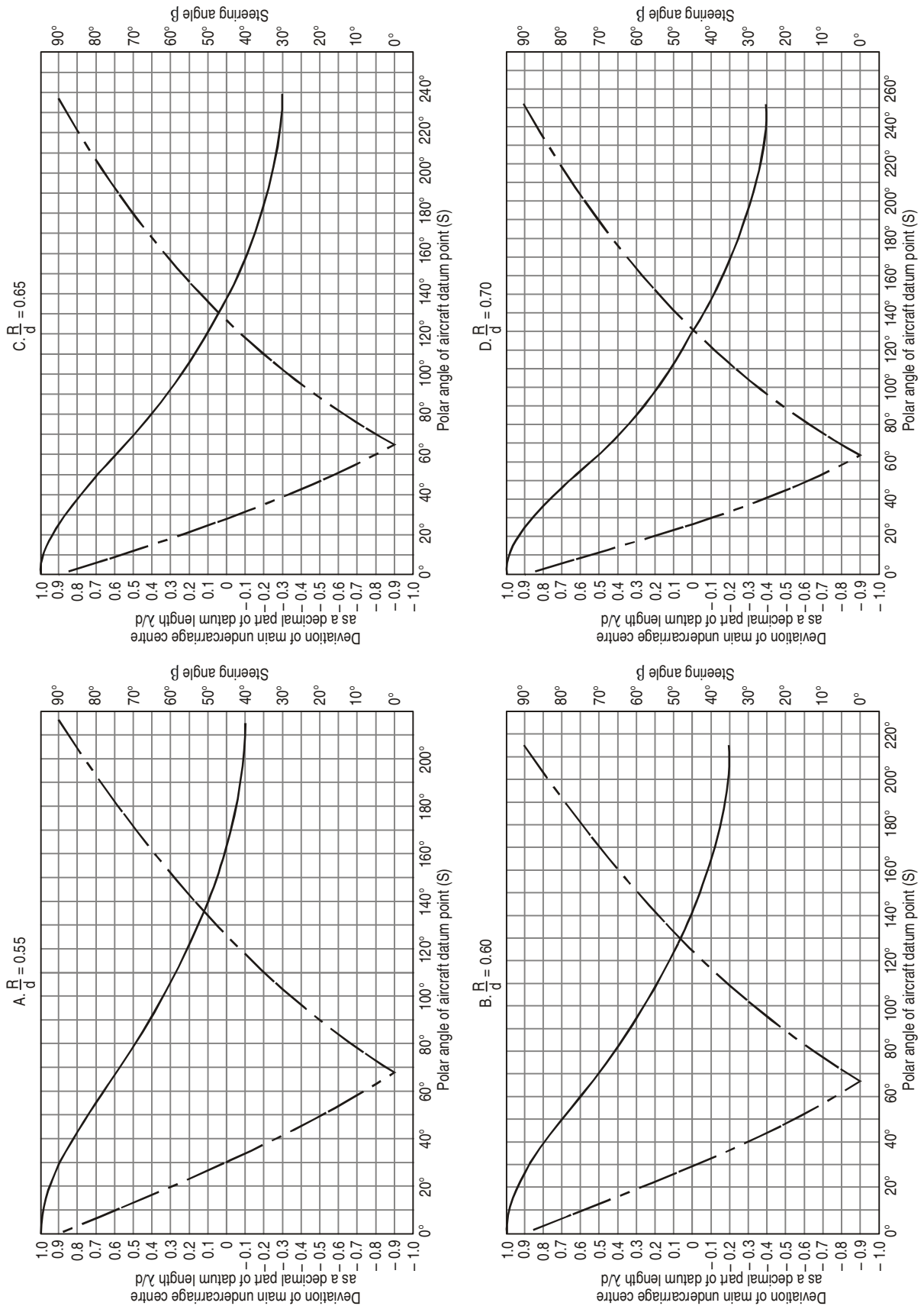

Figure A1-9. Steering angle (β) and deviations (λ) of the main undercarriage centre when the aircraft datum point follows an arc of circle

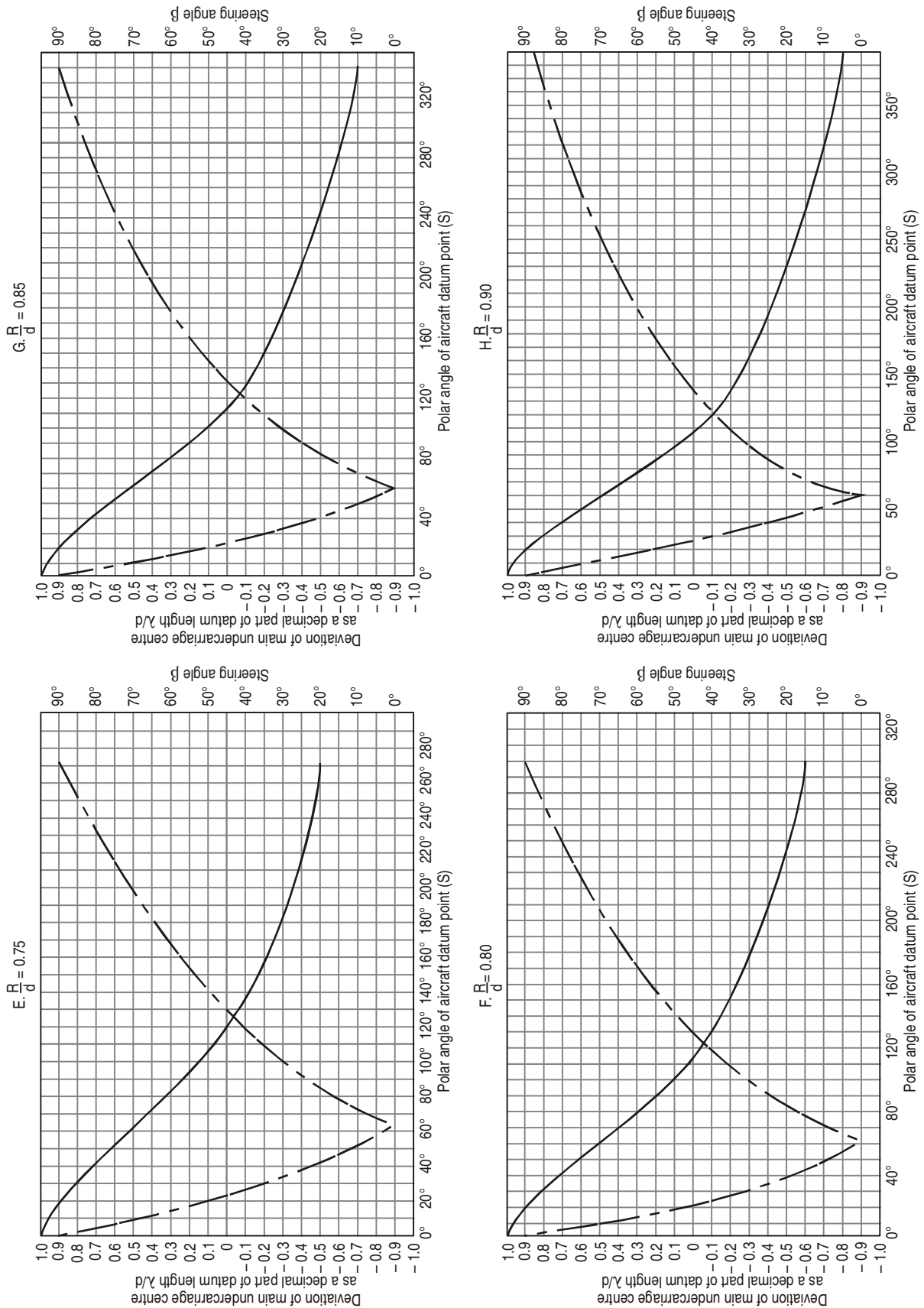

Figure A1-9. Steering angle (β) and deviations (λ) of the main undercarriage centre when the aircraft datum point follows an arc of circle (cont.)

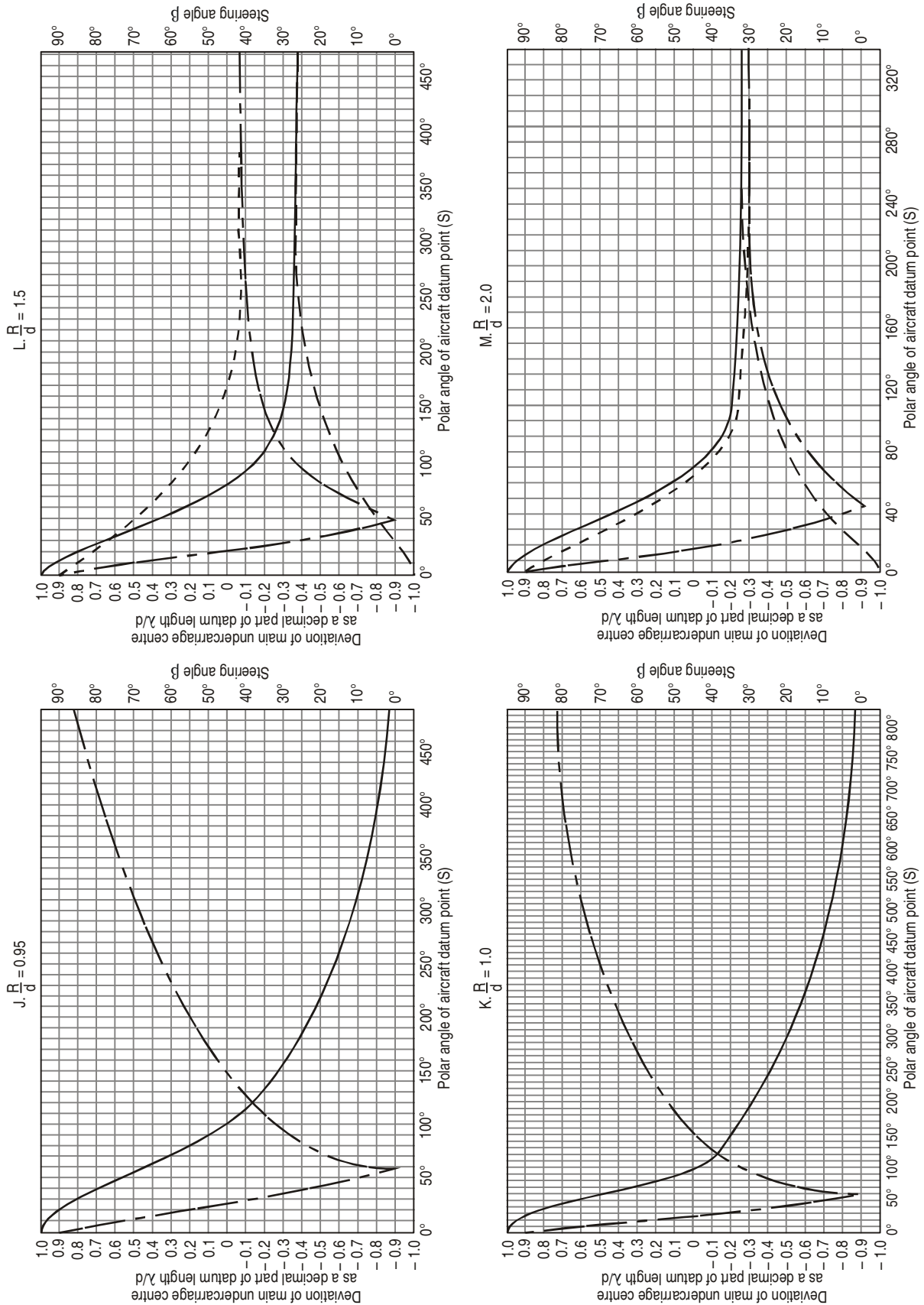

Figure A1-9. Steering angle (β) and deviations (λ) of the main undercarriage centre when the aircraft datum point follows an arc of circle (cont.)

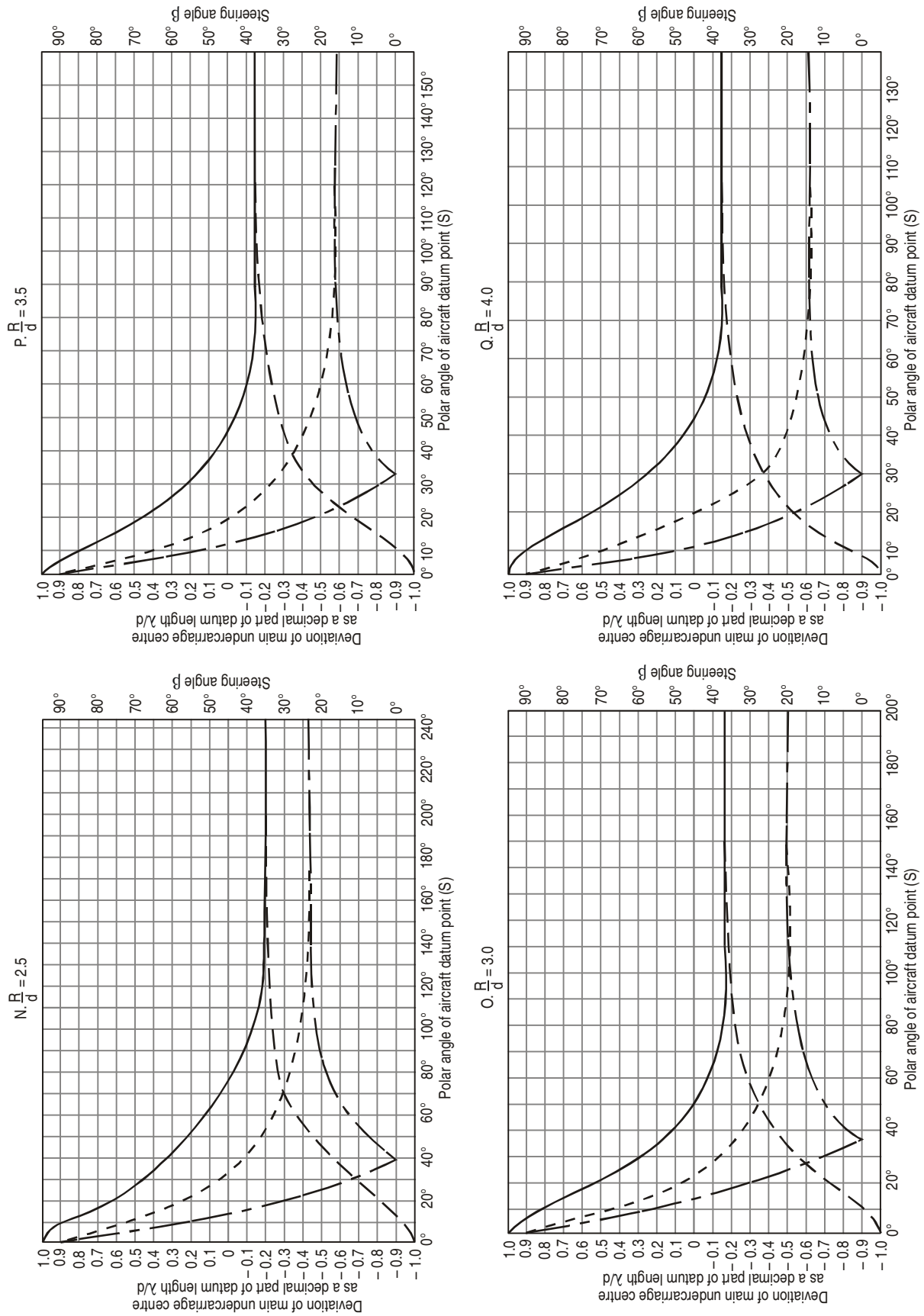

Figure A1-9. Steering angle (β) and deviations (λ) of the main undercarriage centre when the aircraft datum point follows an arc of circle (cont.)

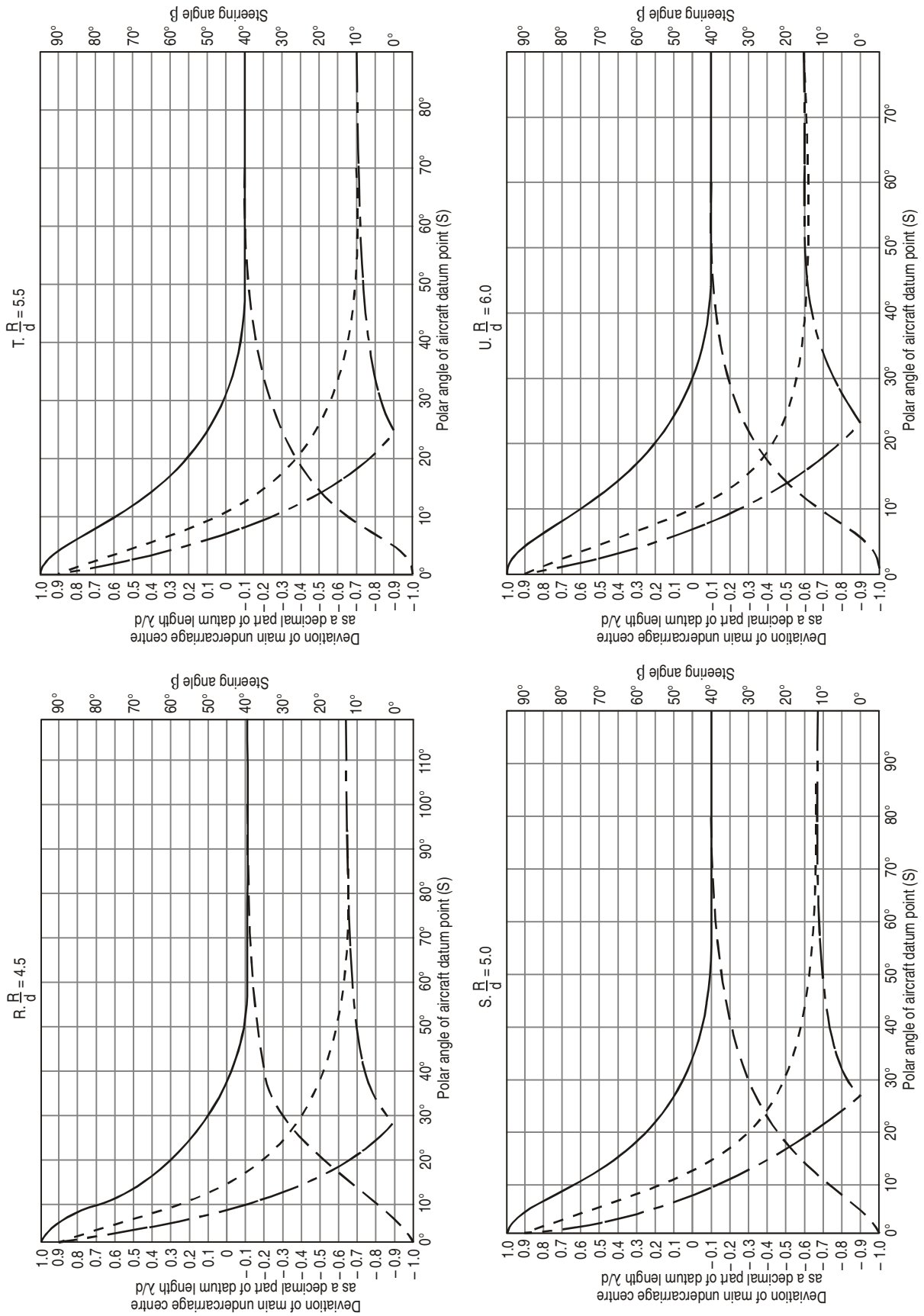

Figure A1-9. Steering angle (β) and deviations (λ) of the main undercarriage centre when the aircraft datum point follows an arc of circle (cont.)

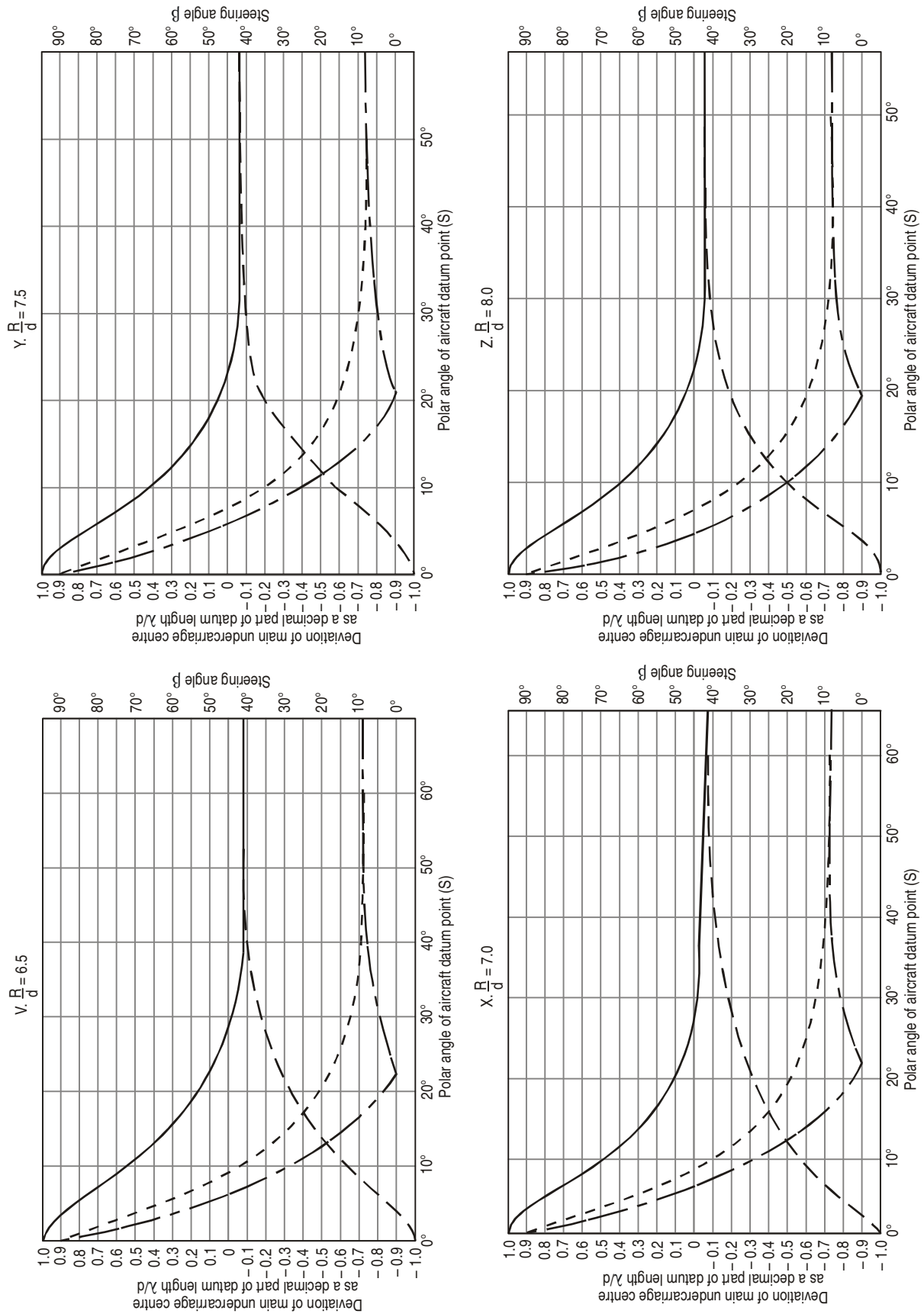

Figure A1-9. Steering angle (β) and deviations (λ) of the main undercarriage centre when the aircraft datum point follows an arc of circle (cont.)

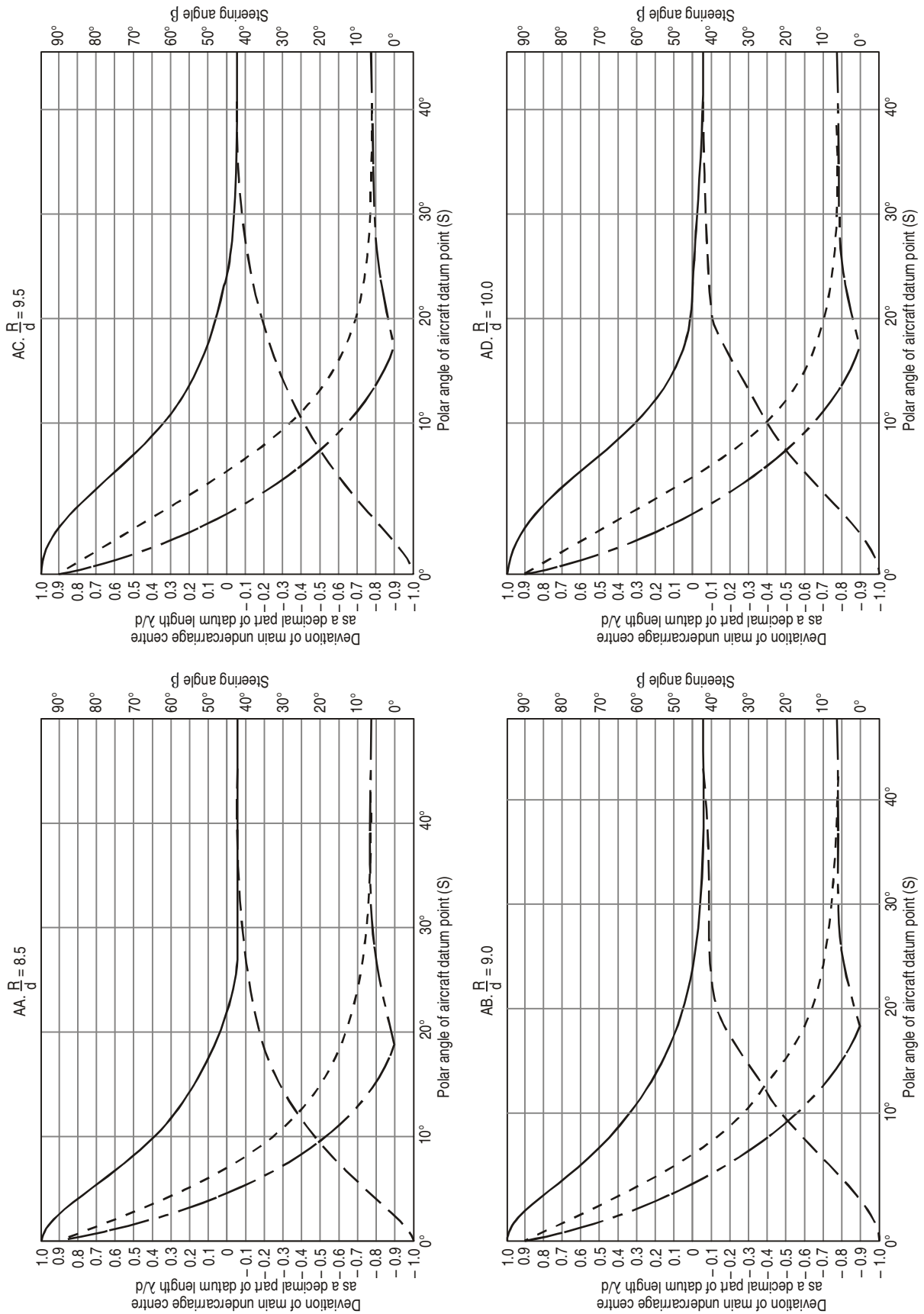

Figure A1-9. Steering angle (β) and deviations (λ) of the main undercarriage centre when the aircraft datum point follows an arc of circle (cont.)

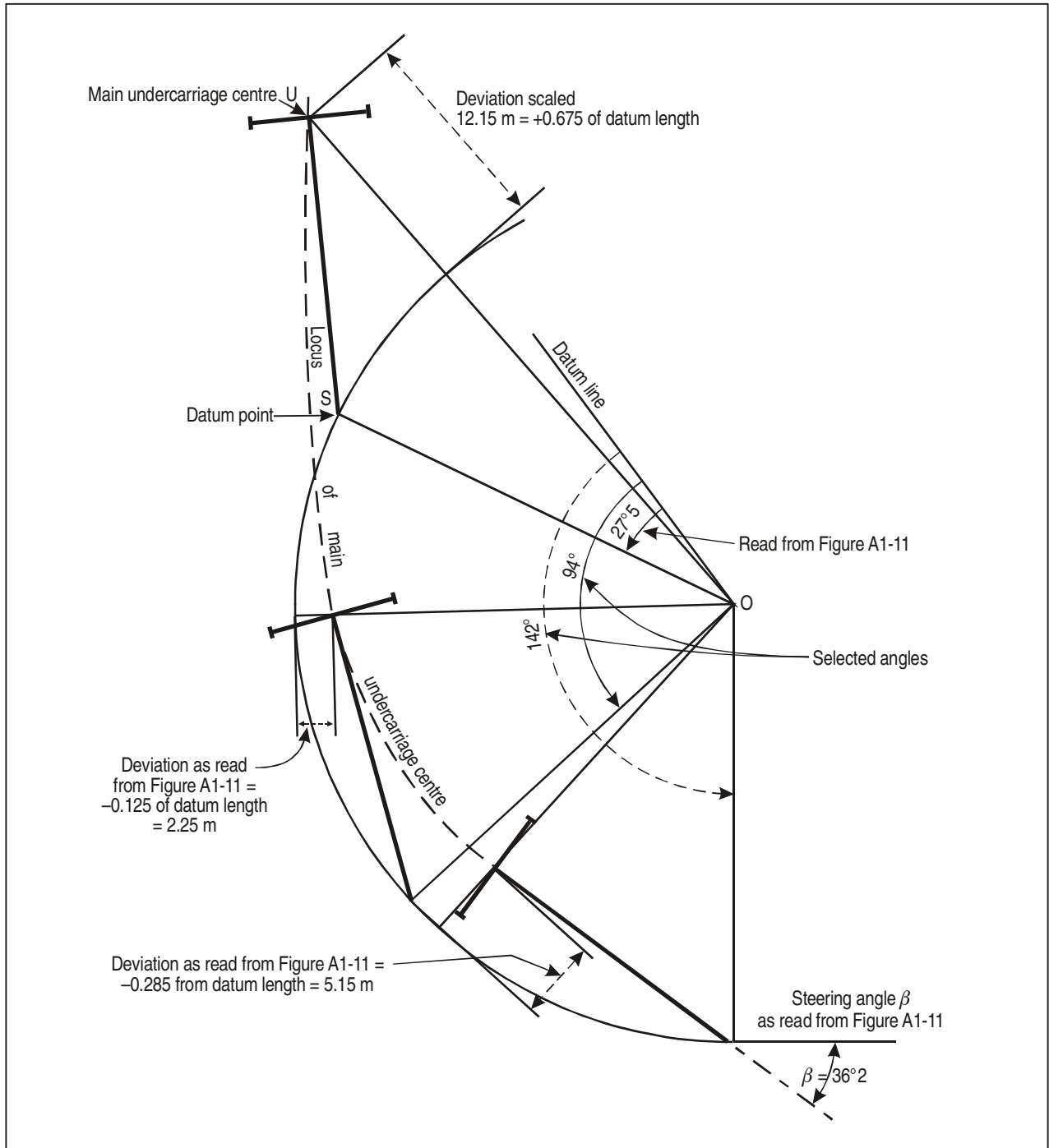

Figure A1-10. Example of locus of main undercarriage centre when datum point follows an arc of circle

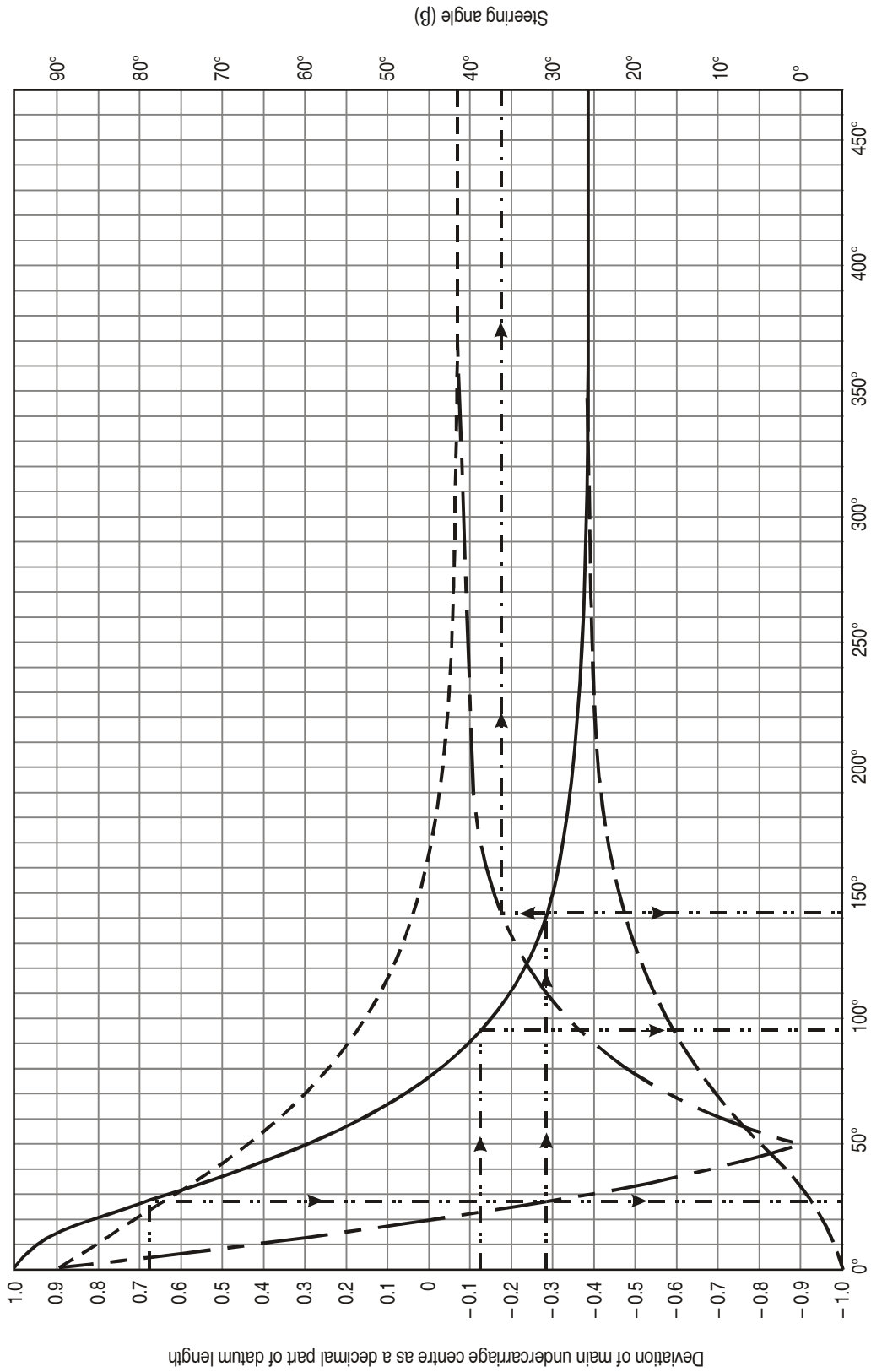

Figure A1-11. Polar angle of aircraft datum point (S)

3. DESIGN OF FILLETS²

3.1 Graphic method

3.1.1 The graphic method consists in determining the fillet by drawing a plan to scale. The scale should be sufficiently large to ensure an adequate accuracy of the drawing. The plan can be drawn in selective stages as described below:

- a) draw the centre lines of the taxiways (or runways) to be connected;
- b) draw the edges of the taxiways and/or runways to be laid on the plan;
- c) draw the path of the main undercarriage centre for the most exacting type of aircraft point by point;
- d) design the fillet.

3.1.2 The path of the undercarriage centre can be drawn by using the graphs on Figures A1-7 and A1-9 as described in 2.2. Various designs are acceptable for the fillet provided that the minimum clearance distances shown in Table A1-1 are complied with. To ensure that these clearance distance requirements are met, a practical method involves drawing a curve parallel to the path of the main undercarriage centre, which is located at a distance equal to $(T/2 + M)$, and then drawing the fillet accordingly.

Example: Design of a fillet
by the graphic method
(see Figure A1-12)

	<i>Data</i> (<i>m</i>)
Taxiway change of direction 90°	
Taxiway centre line radius (<i>R</i>)	36.6
Taxiway width (<i>X</i>)	23.0
Aircraft datum length (<i>d</i>)	18.3
Aircraft undercarriage track (<i>T</i>)	8.0
Safety margin (<i>M</i>)	4.5

Step 1. From Figure A1-9M for $R/d = 2$, extract:

- a) the value of the polar angle for the datum point (*S*) at the beginning of the turn, the corresponding steering angle (β) being *O*;
- b) the associated value or the main undercarriage centre deviation expressed as a decimal part of the datum length which is 0.235. Now list some values of λd and β for a sequence of θ_S (e.g. in increments of 20°). Next, draw the datum line and then plot the points as described in step 3 below.

θ_S	$\frac{\lambda}{d}$	β
43°	+0.235	0
60°	+0.03	13°
80°	-0.11	21°
100°	-0.19	25°
120°	-0.22	27°
133°	-0.24	28°

Step 2. Figure A1-7 enables the following values of λd for a sequence of F/d to be found for the initial deviation $\lambda d = \sin 28^\circ = 0.47$.

$\frac{\lambda}{d}$	0.47	0.35	0.25	0.15	0.10	0.05
$\frac{F}{d}$	0	0.34	0.69	1.21	1.62	2.31

Step 3. The curves can be drawn as follows:

- a) draw the datum line as shown in Figure A1-12;
- b) for each value of θ_S selected in step 1, plot the corresponding point *U*. For this, locate point *S* on the guideline, draw the longitudinal axis of aircraft with corresponding steering angle β and mark *U* at a distance $d = 18.3$ m from *S*. Using the values of λd in step 1, check the accuracy of the plotting;
- c) where the datum point *S* again follows a straight line after coming out of the turn, using the values of λd and F/d from step 2, plot the locus of the undercarriage centre as shown in Figure A1-12;
- d) on a perpendicular dropped from *U* onto the aircraft longitudinal axis, plot a

2. The graphs in this section were prepared by the United Kingdom.

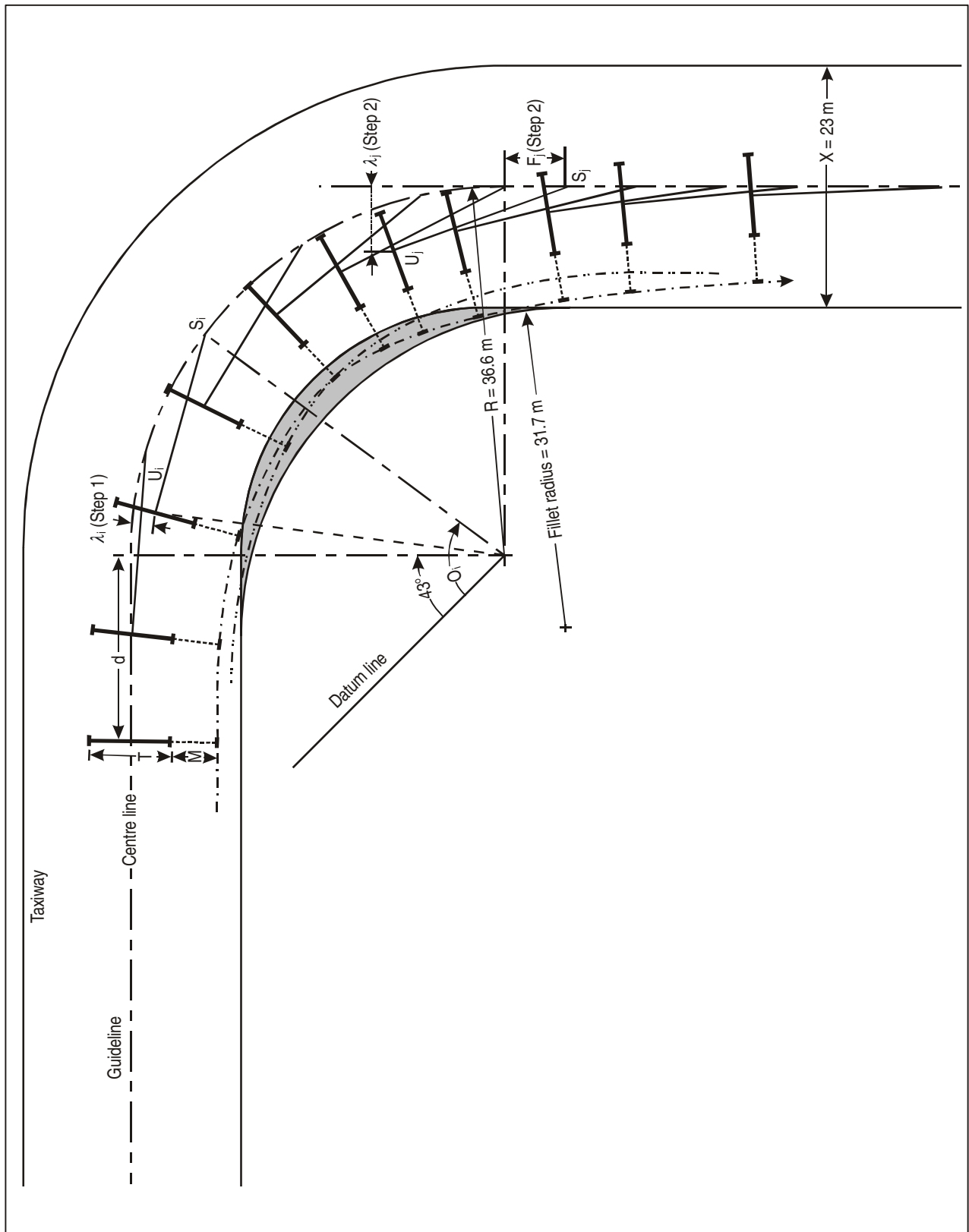

Figure A1-12. Graphic method for designing fillet

distance inwards equal to $(T/2 + M) = 4 + 4.5 = 8.50$ m for each selected position of U . The line through these points is the curve parallel to the path of the main undercarriage centre. This is a theoretical minimum limit for the fillet.

Note.— If the taxiway could be used by aircraft in both directions, draw the relevant curve as well.

- e) select a design of fillet which can easily be staked out. As a rule it is preferable to choose an outline made up of straight sections and an arc of a circle. In the case in question an arc with a radius of 31.7 m is the easiest outline (Figure A1-12).

Step 4. Check the validity of the design, Figure A1-12:

- a) the clearance distance is 4.50 m in compliance with the minimum recommended in Annex 14, Chapter 3 (see Table A1-1);
- b) the maximum value (28°) of the steering angle is compatible with the operational limits of the nose wheel deflection for all the types of aircraft likely to use the aerodrome.

3.2 Arc-and-tangent method

3.2.1 The path of the main undercarriage centre of an aircraft during a turn is a complex curve, but it approximates an arc of a circle and its tangents. A design for a fillet which closely follows the main undercarriage path and allows for the safety margin required can be obtained by using:

- a) an arc concentric with the taxiway centre line in order to provide the necessary additional width of pavement inside the turn; and
- b) a tangent at each end of the arc providing a wedge-shaped end of the fillet to cater for residual deviation of the main undercarriage.

For drawing the fillet, it is sufficient to know the radius (r) of the arc and the length (l) of the wedge-shaped ends of the fillet (see Figure A1-13).

Determination of the radius of the fillet (r)

3.2.2 The fillet radius is equal to:

$$r = R - (\lambda \max + M + \frac{T}{2})$$

in which

- R = radius of taxiway centre line taken as guideline
- $\lambda \max$ = maximum value of the deviation of the main undercarriage
- M = minimum safety margin
- T = track of main undercarriage

3.2.3 The maximum value of the main undercarriage deviation $\lambda \max$ depends on the datum length (d), the radius of curvature of the taxiway centre line (R) and the rate of change in direction. This maximum value is obtained from Figure A1-14 as a percentage of the aircraft datum length for any value of ratio R/d included between 1 and 5.

3.2.4 When the aircraft datum length (d) is greater than the centre line radius (R), a construction line should be used with a value for the radius equal to the datum length, assuming $R/d = 1$. The points at which this construction line joins the straight section of the taxiway centre line should be marked for drawing in the wedge-shaped ends (see 3.2.8).

Determination of the length of the wedge-shaped ends

3.2.5 Filleting is no longer required at the point where the main undercarriage deviation becomes less than the maximum deviation permissible without filleting:

$$\lambda = \frac{X}{2} - (M + \frac{T}{2})$$

where

- X = taxiway width
- M = minimum safety margin
- T = track of main undercarriage

The residual deviation is reached at the end of the turn, when the datum point (S) has covered along the straight taxiway centre line a distance F given by the equation (17) in 2.1.3.1. The length of each wedge-shaped end of the fillet is therefore:

$$l = F - d$$

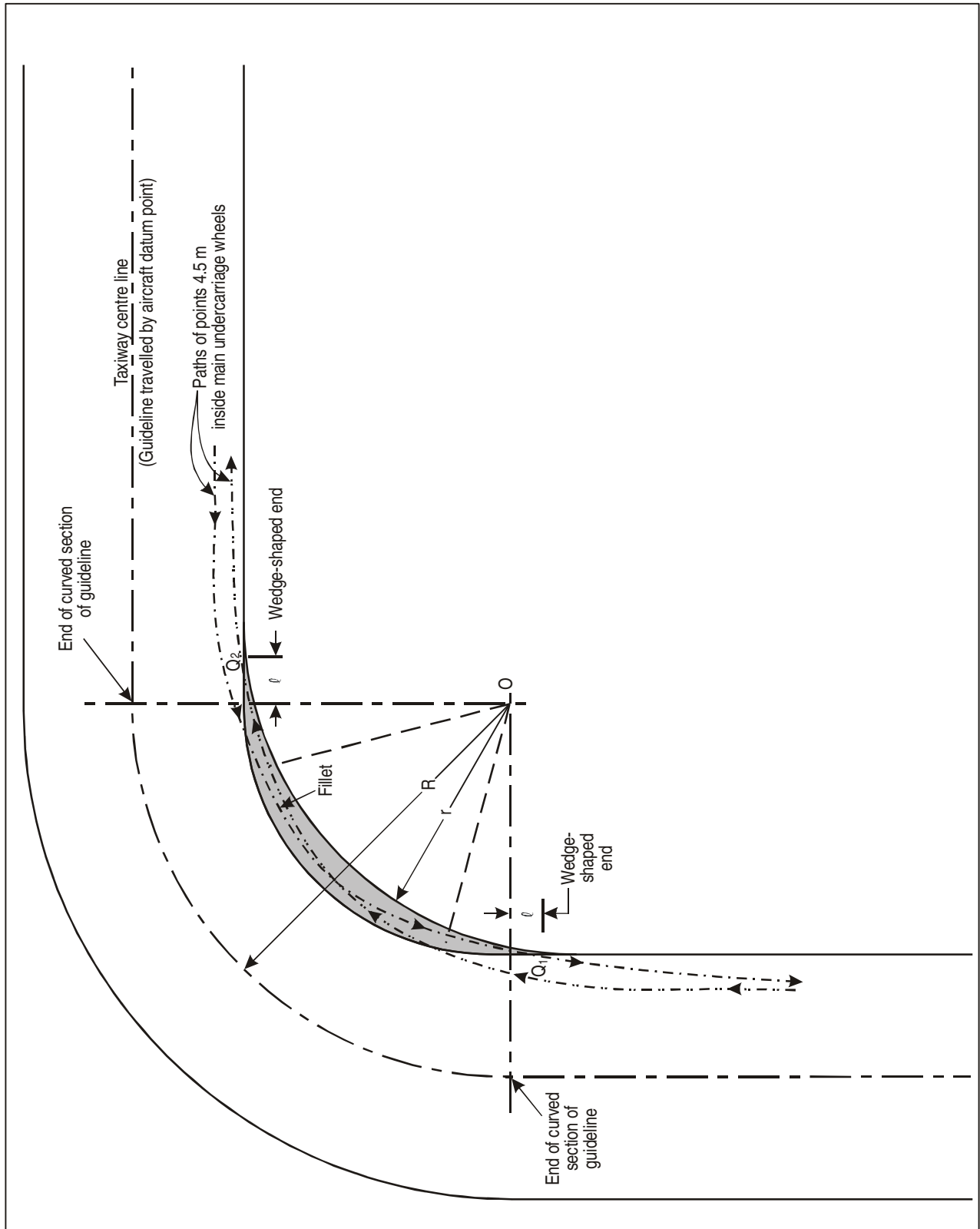

Figure A1-13. Design of a fillet by the arc-and-tangent method showing required clearance distances and calculated fillet

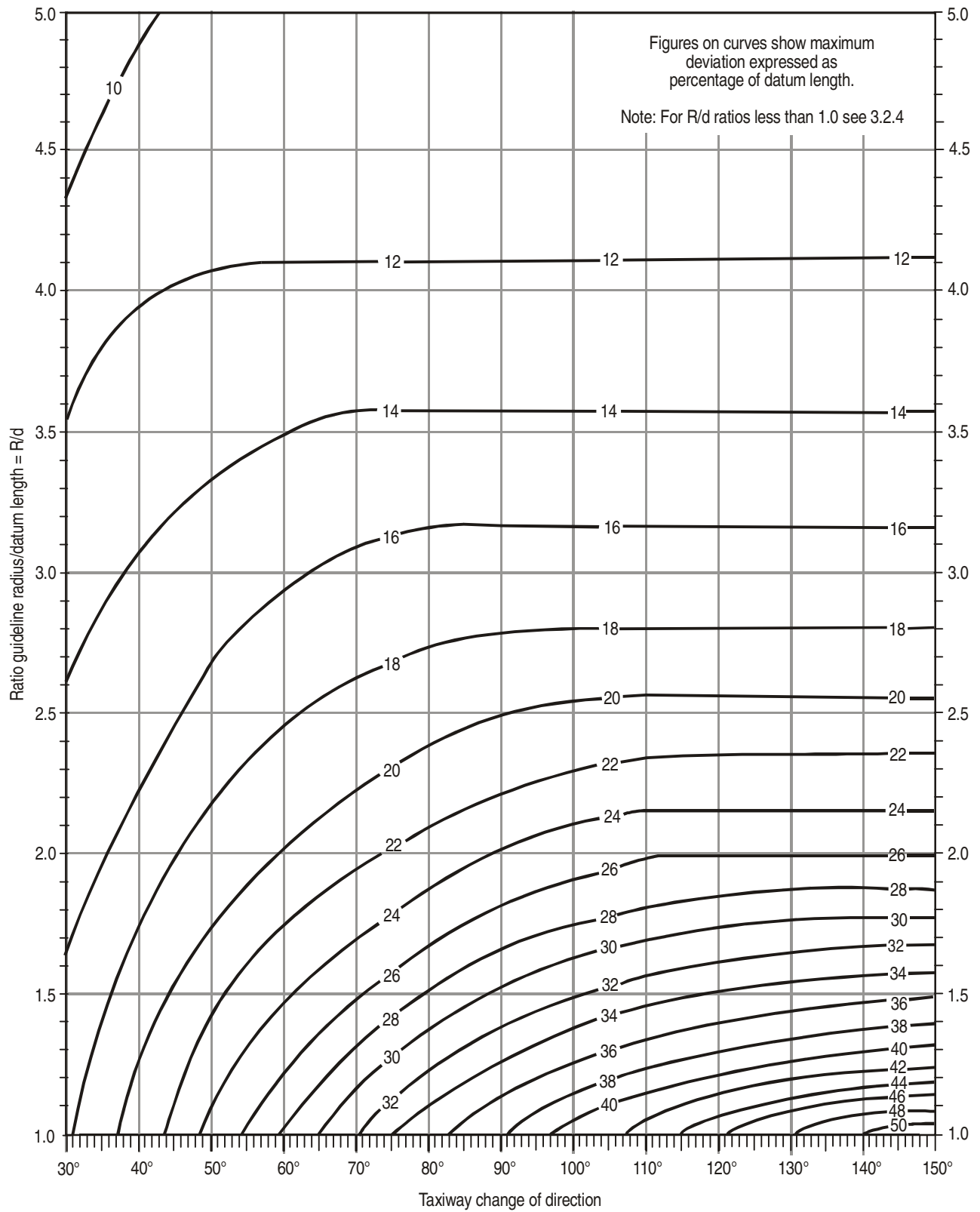

Figure A1-14. Maximum deviation (λ max) of main undercarriage centre

3.2.6 Equation (17) enables F to be expressed as a function of:

- a) β , residual steering angle corresponding to λ , as obtained in 3.2.5 above; and
- b) β max, maximum value of the steering angle during a turn. This value is reached when λ is equal to λ max, as given by Figure A1-14.

Use of prepared graphs avoids all calculation. The residual steering angle reached when the deviation is equal to the maximum permissible deviation without filleting is obtainable from Figure A1-15. (Figures are given to cover a datum length range between 12 and 60 m.) The maximum value of the steering angle during a turn is obtained from Figure A1-16 by reading from the taxiway change of direction to the ratio R/d and across to obtain the steering angle. Finally, Figure A1-17 enables the values of the steering angle to be converted into displacements along the straight guideline.

3.2.7 Care should be taken to ensure that the steering angle does not exceed the maximum nose wheel angle of the aircraft which are expected to use the aerodrome. If that were the case, the radius of curvature of the guideline and the size of fillet would have to be increased.

Note.— Because the datum point does not generally coincide with the nose wheel, this introduces a slight error. This error, however, is on the safe side.

Drawing the fillet

3.2.8 The required fillet is obtained as follows:

- a) Draw an arc concentric with the taxiway centre line using radius (r) (or, if necessary, an arc concentric with the construction line mentioned in 3.2.4).
- b) Along the inside edge of the taxiway, mark Q_1 and Q_2 at distance l from the curved section of the guideline, as shown in Figure A1-13.
- c) From the points obtained in (b) above, draw tangents to the arc with radius (r).

3.2.9 The arc-and-tangent method is illustrated in Example 1.

Variant of arc-and-tangent method

3.2.10 A closer approximation to the required fillet can be obtained by the use of two fairing lines. The second point is obtained by recalculating the maximum permissible deviation without fillet but using a smaller safety margin. The practical method and the result obtained are illustrated in Example 2.

3.3 Quick reference graph method

3.3.1 The quick reference graphs enable the fillets of taxiways to be designed in a relatively simple manner, provided that constant values are given to certain variables:

- the width of the taxiways and the minimum clearance distance: corresponding to the code letter of longest runway served;
- datum length and undercarriage track: corresponding to most demanding type of aircraft involved.

3.3.2 Figure A1-20 has been prepared for a particular type of aircraft, namely the Boeing 747, and has been plotted on the basis of the following constant values, as recommended by Annex 14:

- X — width of taxiways = 23 m
- M — minimum clearance distance = 4.5 m

and taking as a guideline the taxiway centre line. In accordance with the provisions of Annex 14, the datum point selected is located vertically beneath the cockpit. The following constant values relate to this type of aircraft:

<i>Parameter</i>	<i>B747 (m)</i>
Datum length of aircraft (d)	27.7
Undercarriage track (T)	12.8

3.3.3 The edge of the fillet (Figure A1-21) is determined as follows:

- Step 1.* First the radius of the fillet arc (r) is determined by plotting the point corresponding to the change in direction of the taxiway and of the centre line curve radius on graph A in Figure A1-20. The value obtained

by interpolation between the curves drawn for round values of r is used to draw an arc concentric to that of the guideline.

Step 2. The distance travelled (F) from the point when the fillet becomes unnecessary is obtained in the same manner by means of graph B on Figure A1-20. This gives the

distance from the point where the inside edge of the taxiway becomes straight again.

Step 3. The arc tangents are drawn so that they intersect the edge of the taxiway at the end of the distance travelled (F). The line obtained is the required fillet as shown in the diagram (Figure A1-21).

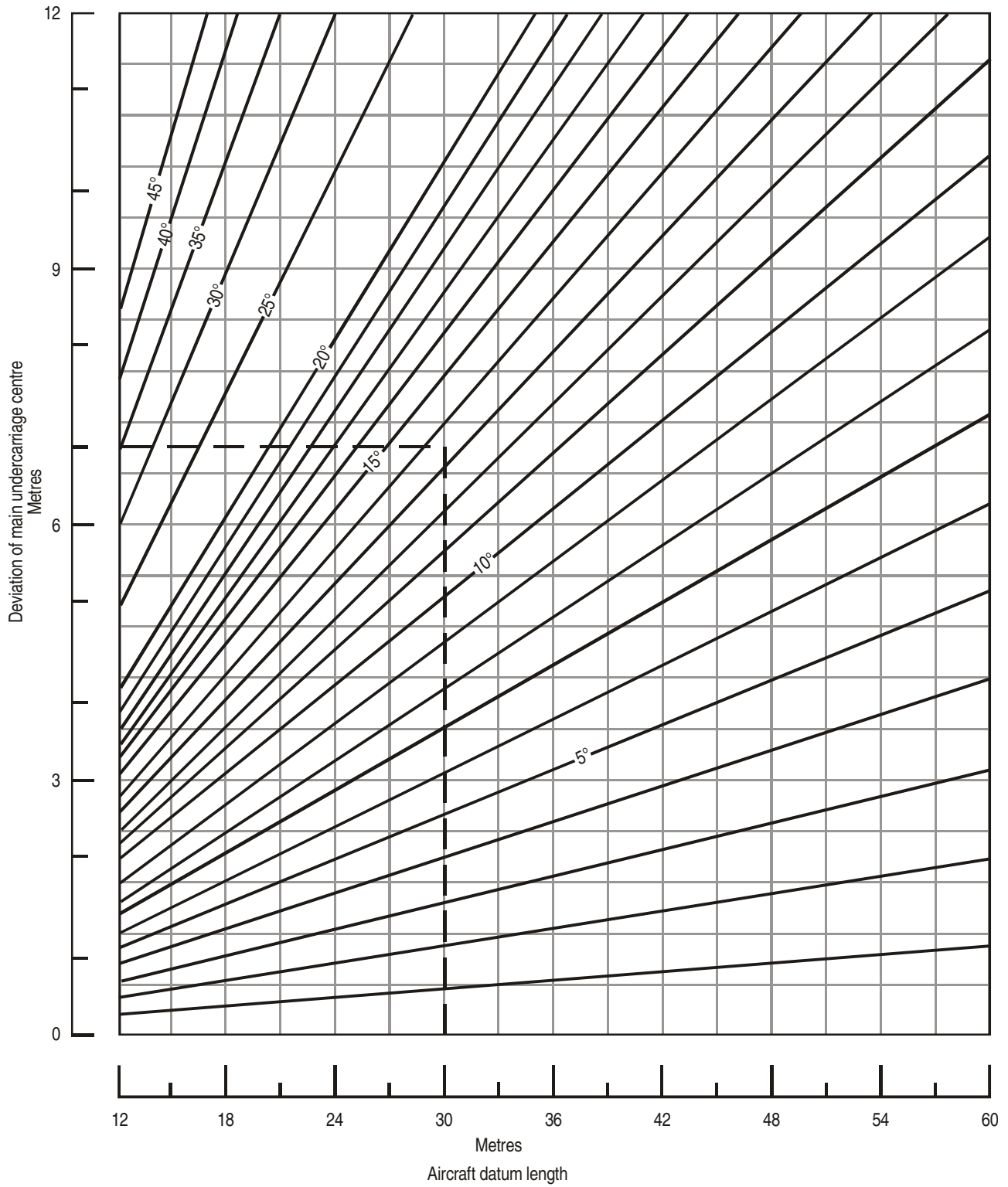

Figure A1-15. Steering angle (β) and main undercarriage centre deviation (λ) (Figures and sloping lines show steering angles)

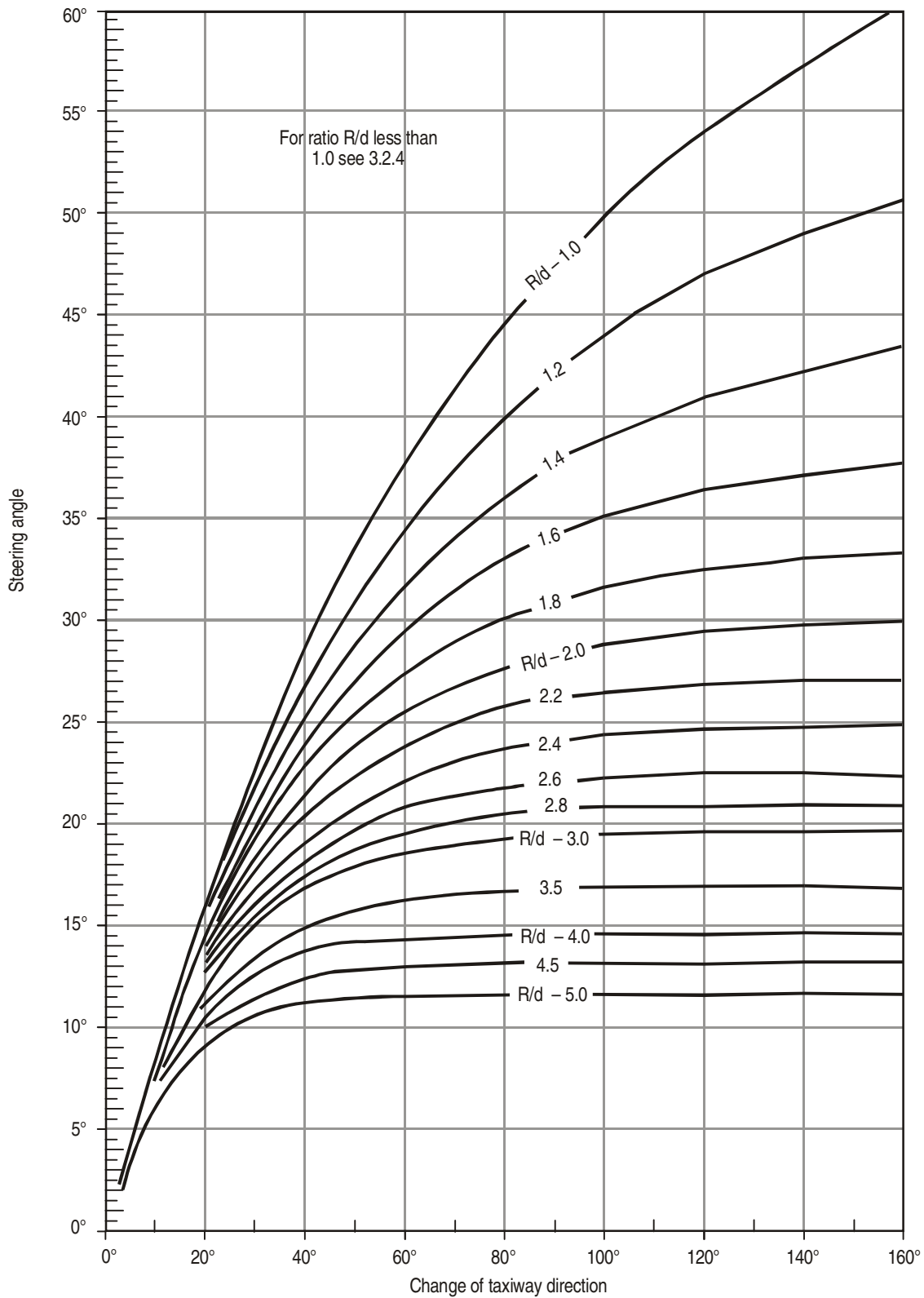

Figure A1-16. Increase of steering angle during a turn

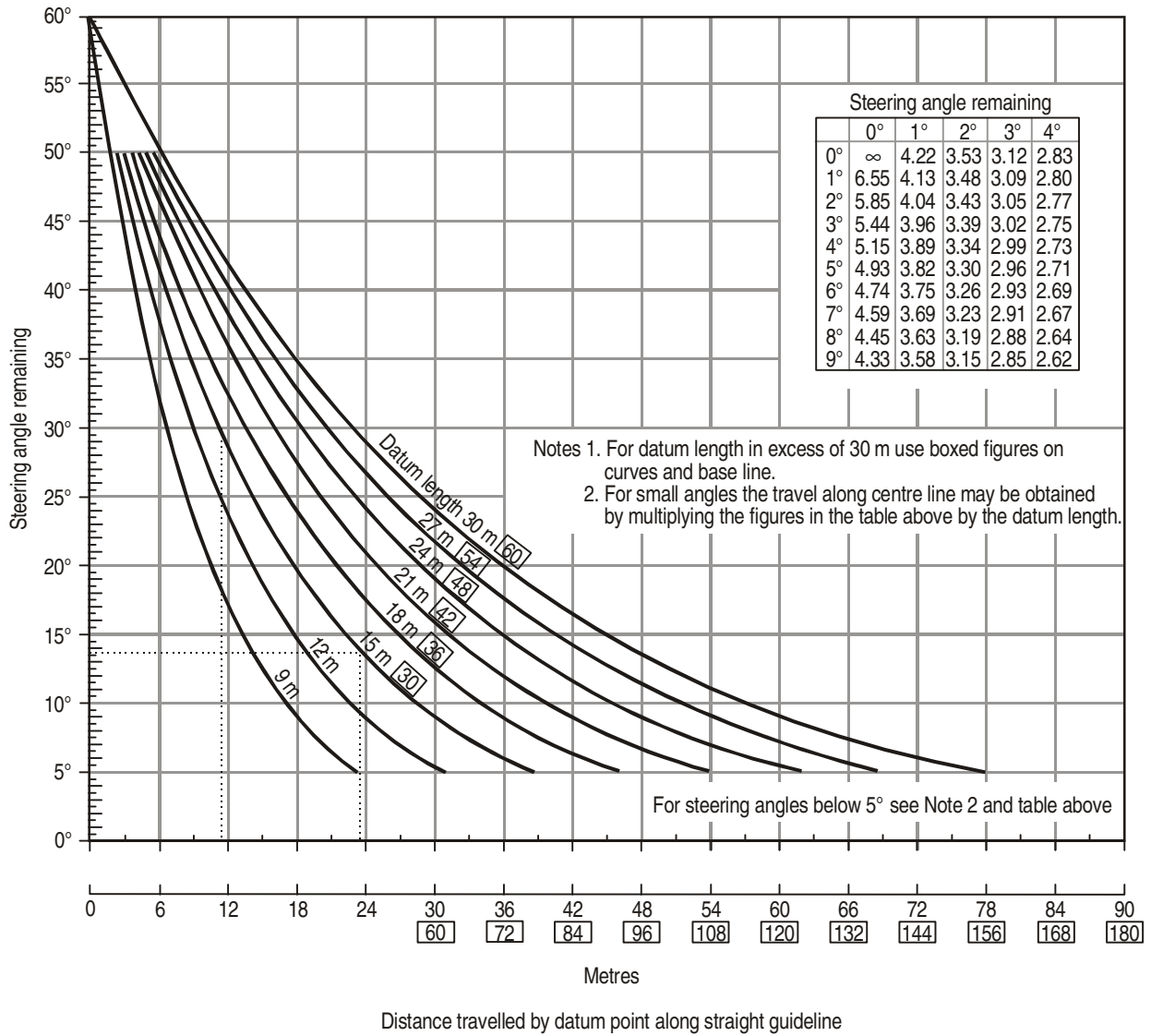

Figure A1-17. Decrease of steering angle on completion of turn

Example 1: Fillet design using arc-and-tangent method
 (see Figure A1-18)

	Data (metres)
Taxiway change of direction 135°	
Taxiway centre line radius (R)	42
Taxiway width (X)	23
Aircraft datum length (d)	22
Aircraft undercarriage track (T)	8
Safety margin (M)	4.5
Ratio $\frac{R}{d} =$	$\frac{42}{22} = 1.9$
Maximum deviation (Figure A1-14) is 27% of d	$\lambda \text{ max} = 6 \text{ m}$
Radius of fillet arc $r = R - (\lambda \text{ max} + \frac{T}{2} + M)$	$42 - (6 + 4 + 4.5) = 27.5 \text{ m}$
Maximum deviation without filleting $= \frac{X}{2} - (M + \frac{T}{2})$	$11.5 - (4.5 + 4) = 3 \text{ m}$
From Figure A1-15 this is equivalent to a steering angle of 7.6°.	
Enter Figure A1-16 and obtain steering angle at end of turn (135°, $R/d = 1.9$) extract 31°.	
These steering angles are converted to travel along the straight centre line by use of Figure A1-17. 7.6° gives a distance L_1 and 31° a distance L_2 . The difference L_3 between L_1 and L_2 is the datum travel to reduce the steering angle from 31° to 7.6°.	$L_1 = 47.9 \text{ m}$ $L_2 = 16.5 \text{ m}$ $L_3 = 31.4 \text{ m}$
The distance the undercarriage centre is beyond the end of the curve is obtained by subtracting datum length from L_3 .	$31.4 - 22 = 9.4 \text{ m}$
Plot	
1. Centre O (taxiway curve centre), radius 27.5 m draw an arc.	
2. Mark points at a distance 9.4 m beyond end of curve on inner edge of taxiway.	
3. Draw lines from these points as tangents to the arc.	

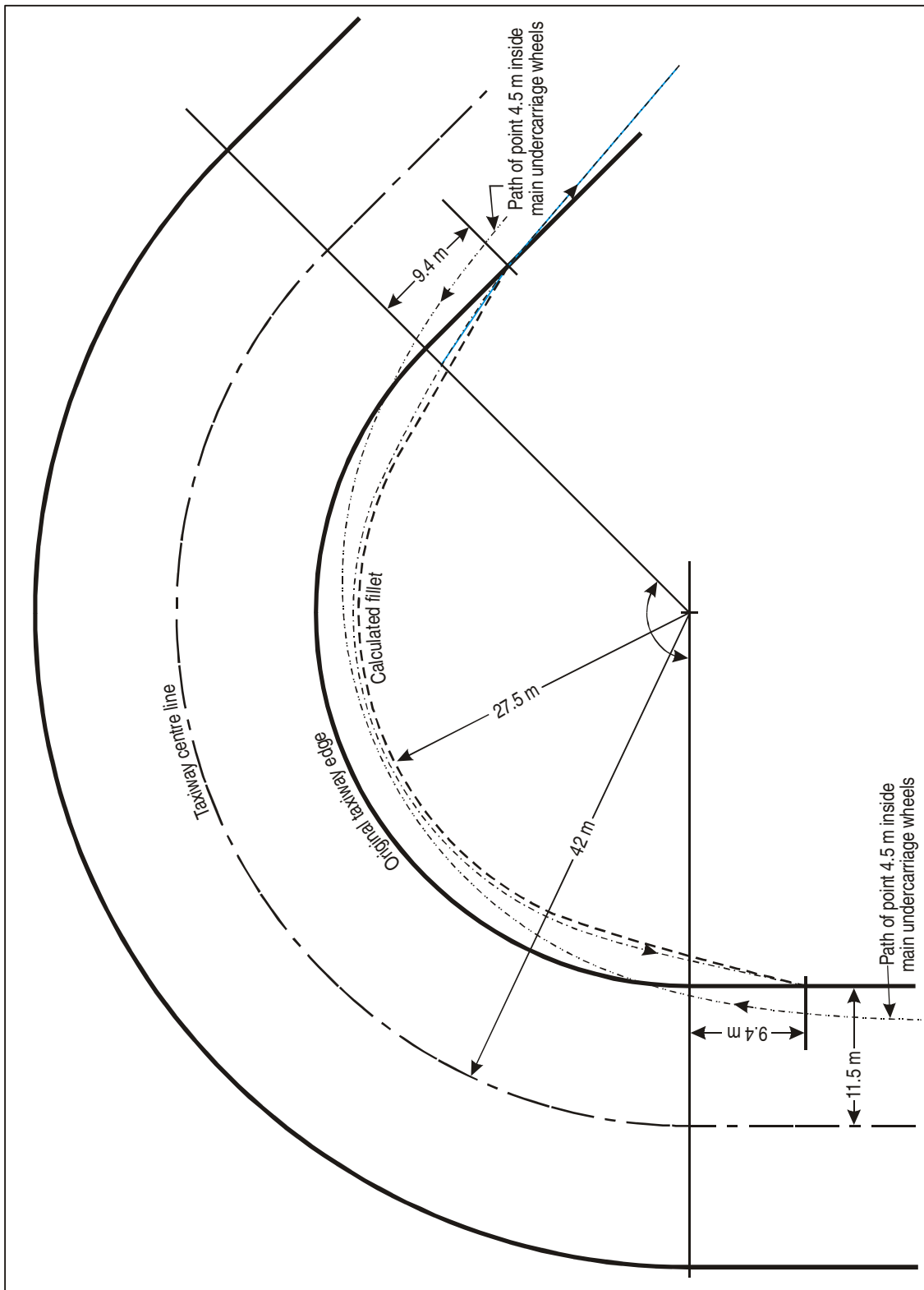

Figure A1-18. Typical fillet design, arc-and-tangent method (see Example 1)

Example 2: Compound fillet for long-datum, wide-track aircraft
 (see Figure A1-19)

	Data (metres)
Taxiway change of direction 90°	
Taxiway centre line radius (R)	34.3
Taxiway width (X)	23
Aircraft datum length (d)	25.6
Aircraft wheel track (T)	13.1
Safety margin (M)	4.6
To obtain first fillet point	
Ratio $\frac{R}{d} =$	$\frac{34.3}{25.6} = 1.34$
Maximum deviation (Figure A1-14) is 32.6% of d .	$\lambda \text{ max} = 8.3 \text{ m}$
Radius of fillet arc $r = R - (\lambda \text{ max} + \frac{T}{2} + M)$	$34.3 - (8.3 + 6.6 + 4.6) = 14.8 \text{ m}$
Maximum deviation without filleting = $\frac{X}{2} - (M + \frac{T}{2})$	$11.5 - (4.6 + 6.6) = 0.3 \text{ m}$
From Figure A1-15 this is equivalent to a steering angle of 0.7°.	
Enter Figure A1-16 and obtain steering angle at end of turn (90°, $R/d = 1.34$) 39°.	
These steering angles are converted to travel along the straight centre line by use of Figure A1-17. 0.7° is below the curves on the graph so the table is used, entering under 0° column against increment of 0.7° and extracting a figure of 4.59. The distance travelled is $4.59 \times d = L_1$. 39° is resolved from the graph as L_2 .	$L_1 = 4.59 \times 25.6 = 117.5 \text{ m}$
The difference L_3 between L_1 and L_2 is the datum travel to reduce 39° to 0.7°.	$L_2 = 12.5 \text{ m}$ $L_3 = 105 \text{ m}$
The distance the undercarriage centre is beyond the end of the curve is obtained by subtracting datum length from L_3 .	$105 - 25.6 = 79.4 \text{ m}$

Data
(metres)

To obtain second fillet point

The second fillet point is obtained by recalculating the data above using a lower value M for safety margin.

The following steps are unchanged:

- a) Ratio $R/d = 1.34$
- b) Maximum deviation $\lambda_{\max} = \lambda_{\max} = 8.3$ m
- c) Steering angle at end of turn = 39°
- d) Datum travel to reduce 39° is $L_2 = 12.5$ m

Selected new value for safety margin (M_1) = 1.5 m

$$\text{Maximum deviation without filleting} = \frac{X}{2} - (M_1 + \frac{T}{2}) \qquad 11.5 - (1.5 + 6.6) = 3.4 \text{ m}$$

From Figure A1-15 this is equivalent to a steering angle of 7.5° which is converted (Figure A1-17) to a datum travel of L_1 . The difference L_3 between L_1 and L_2 is the datum travel to reduce 39° to 7.5° .

$$\begin{aligned} L_1 &= 55.5 \text{ m} \\ L_3 &= 55.5 - 12.5 = 43 \text{ m} \end{aligned}$$

The distance the undercarriage centre is beyond the end of the curve is obtained by subtracting datum length from L_3 .

$$43 - 25.6 = 17.4 \text{ m}$$

This point gives a safety margin of 1.5 m. As 4.6 m is required, the final fillet must pass 3.1 m inside this point.

Plot

1. Centre O (taxiway curve centre), radius 14.8 m draw an arc.
 2. Mark points at a distance 17.4 m beyond end of curve on inner edge of taxiway.
 3. Centre points marked in 2 above radius 3.1 m draw arcs.
 4. Draw the common tangents to the arcs described in 1 and 3 above.
 5. Mark points 79.4 m beyond end of curve on inner edge of taxiway.
 6. Draw lines from these points as tangents to arcs described in 3 above.
-

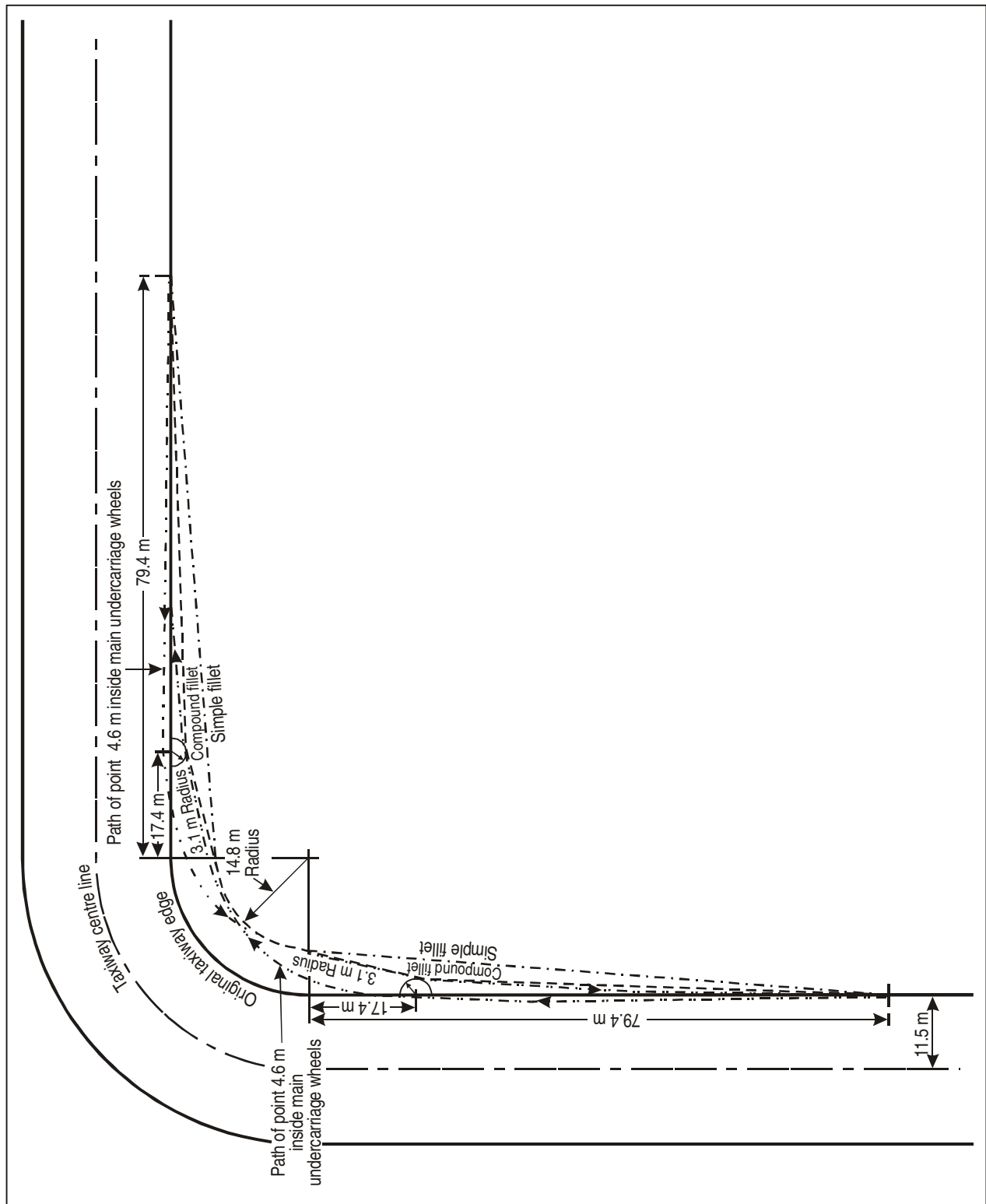
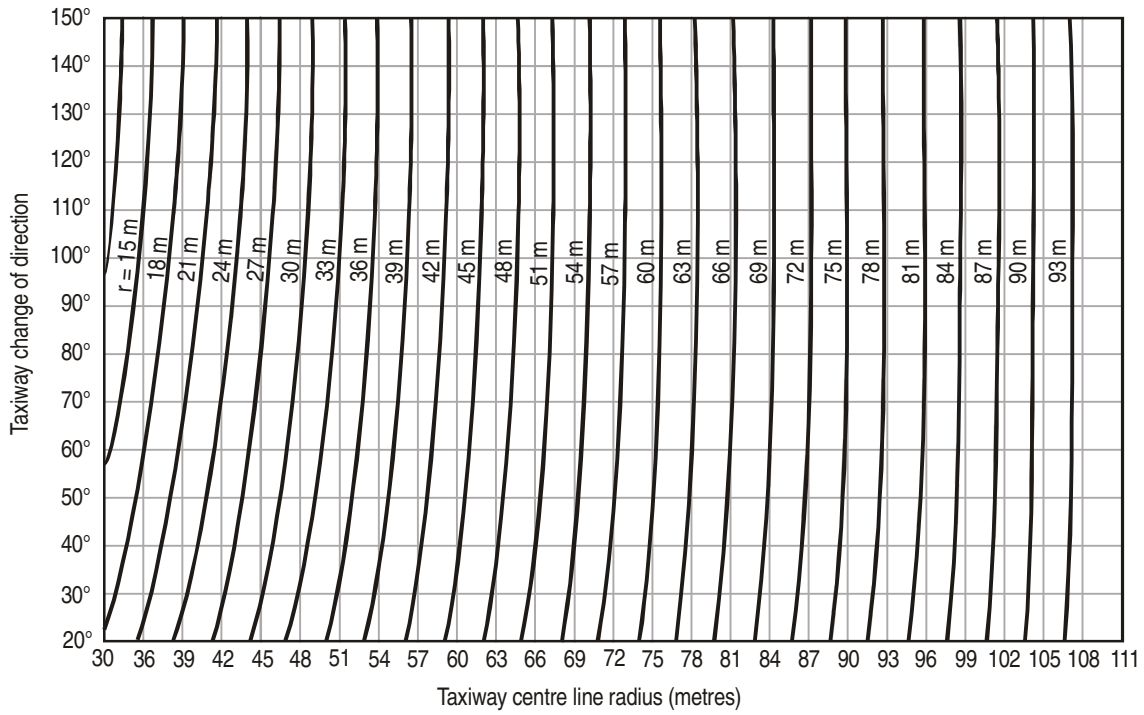

Figure A1-19. Compound fillet for long-datum, wide-track aircraft
(see Example 2)

Graph A — Radius of fillet arc (r)



Graph B — Travelled distance (F)

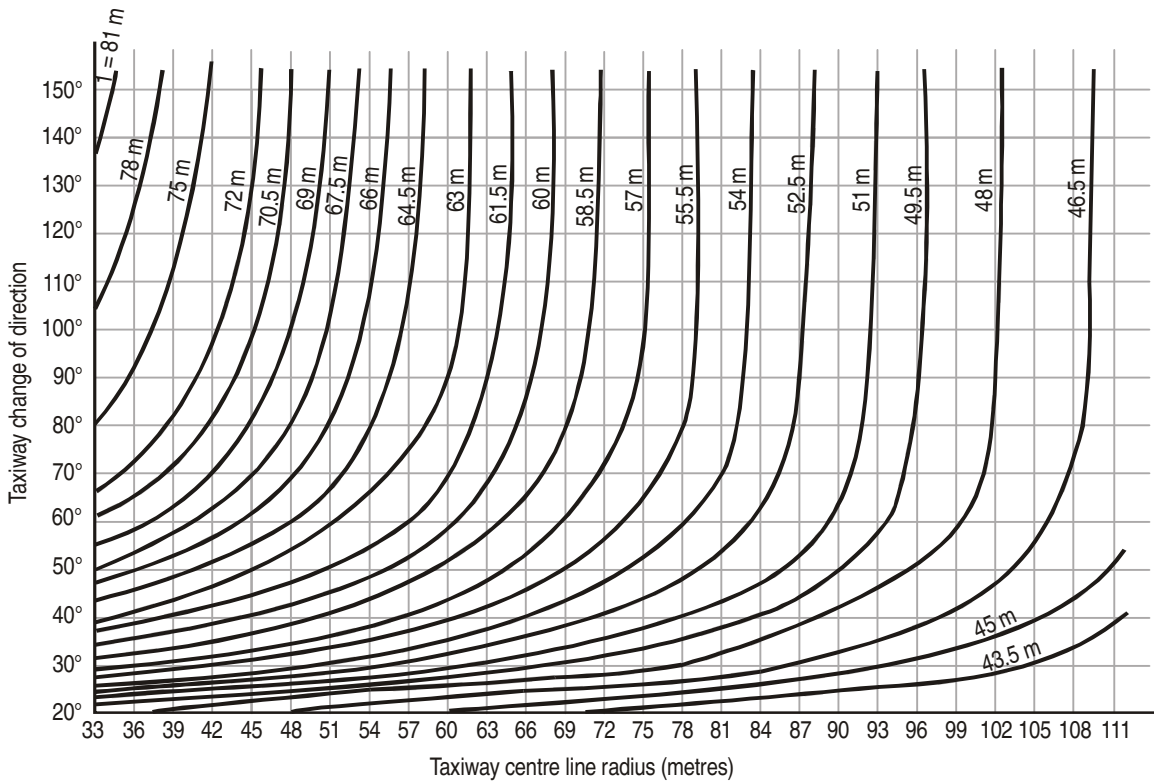

Figure A1-20. Quick reference graph for Boeing 747 (cockpit over taxiway centre line)

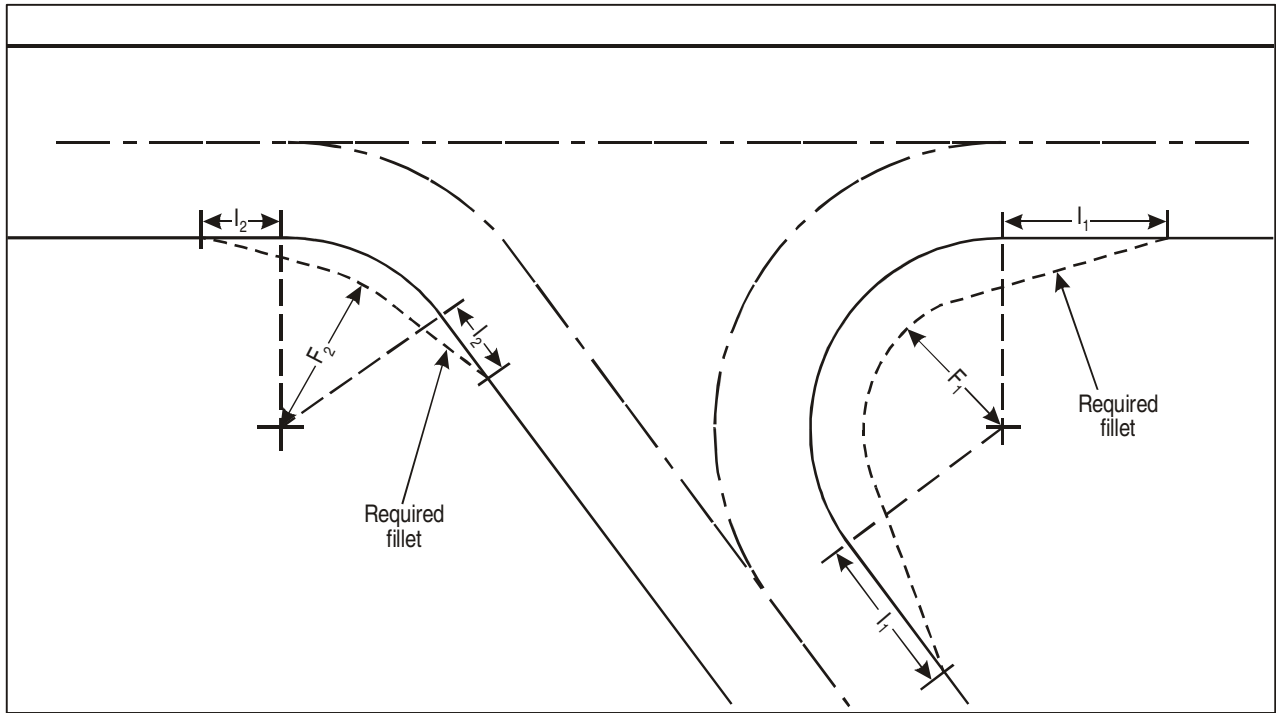

Figure A1-21. Taxiway fillet diagram

Table A1-1. Relationship between steering angle and nose wheel deflection angle

Nose wheel deflection angle (°)	X = 1.0	X = 1.1	X = 1.2	X = 1.3	X = 1.4	X = 1.5	X = 1.6	X = 1.7	X = 1.8	X = 1.9	X = 2.0
0.5	0.500	0.550	0.600	0.650	0.700	0.750	0.800	0.850	0.900	0.950	1.000
1.0	1.000	1.100	1.200	1.300	1.400	1.500	1.600	1.700	1.800	1.899	1.999
1.5	1.500	1.650	1.800	1.950	2.100	2.249	2.399	2.549	2.699	2.848	2.998
2.0	2.000	2.200	2.400	2.599	2.799	2.998	3.198	3.397	3.597	3.796	3.995
2.5	2.500	2.750	2.999	3.249	3.498	3.747	3.996	4.245	4.494	4.742	4.991
3.0	3.000	3.299	3.599	3.898	4.196	4.495	4.793	5.091	5.389	5.686	5.984
3.5	3.500	3.849	4.198	4.546	4.894	5.242	5.589	5.936	6.283	6.629	6.974
4.0	4.000	4.399	4.797	5.194	5.591	5.988	6.384	6.779	7.174	7.568	7.961
4.5	4.500	4.948	5.395	5.842	6.288	6.733	7.177	7.621	8.063	8.505	8.945
5.0	5.000	5.497	5.993	6.489	6.983	7.476	7.969	8.460	8.949	9.438	9.925
5.5	5.500	6.046	6.591	7.135	7.677	8.219	8.758	9.296	9.833	10.368	10.900
6.0	6.000	6.595	7.188	7.780	8.371	8.959	9.546	10.131	10.713	11.293	11.871
6.5	6.500	7.144	7.785	8.425	9.063	9.698	10.331	10.962	11.590	12.215	12.837
7.0	7.000	7.692	8.382	9.069	9.754	10.436	11.115	11.790	12.463	12.132	13.797
7.5	7.500	8.240	8.978	9.712	10.443	11.171	11.895	12.615	13.332	14.044	14.751
8.0	8.000	8.788	9.573	10.354	11.131	11.904	12.673	13.437	14.196	14.951	15.700
8.5	8.500	9.336	10.167	10.995	11.818	12.635	13.448	14.255	15.057	15.852	16.642
9.0	9.000	9.883	10.761	11.635	12.502	13.364	14.220	15.070	15.912	16.748	17.577
9.5	9.500	10.430	11.355	12.273	13.185	14.091	14.989	15.880	16.763	17.638	18.505
10.0	10.000	10.977	11.947	12.911	13.867	14.815	15.755	16.686	17.609	18.522	19.425
10.5	10.500	11.523	12.539	13.547	14.546	15.536	16.517	17.488	18.449	19.399	20.339
11.0	11.000	12.069	13.130	14.181	15.223	16.255	17.276	18.286	19.284	20.270	21.244
11.5	11.500	12.612	13.720	14.815	15.899	16.971	18.031	19.079	20.113	21.134	22.142
12.0	12.000	13.160	14.309	15.447	16.572	17.684	18.783	19.867	20.937	21.992	23.031
12.5	12.500	13.705	14.898	16.077	17.243	18.394	19.530	20.650	21.754	22.842	23.912
13.0	13.000	14.249	15.485	16.706	17.912	19.101	20.274	21.429	22.566	23.685	24.784
13.5	13.500	14.793	16.071	17.333	18.578	19.805	21.013	22.202	23.371	24.520	25.648
14.0	14.000	15.337	16.657	17.959	19.242	20.505	21.748	22.970	24.170	25.348	26.503
14.5	14.500	15.880	17.241	18.583	19.904	21.203	22.479	23.733	24.963	26.168	27.350
15.0	15.000	16.423	17.825	19.205	20.563	21.896	23.206	24.490	25.748	26.981	28.187
15.5	15.500	16.965	18.407	19.825	21.219	22.587	23.928	25.242	26.528	27.785	29.015
16.0	16.000	17.506	18.988	20.444	21.873	23.273	24.645	25.988	27.300	28.582	29.834
16.5	16.500	18.047	19.568	21.061	22.524	23.957	25.358	26.728	28.066	29.371	30.644
17.0	17.000	18.588	20.147	21.675	23.172	24.636	26.066	27.463	28.825	29.152	31.444
17.5	17.500	19.128	20.725	22.288	23.818	25.312	26.770	28.192	29.577	30.924	32.235
18.0	18.000	19.667	21.301	22.899	24.460	25.984	27.469	28.915	30.321	31.689	33.017
18.5	18.500	20.206	21.876	23.508	25.100	26.652	28.162	29.632	31.059	32.445	33.790
19.0	19.000	20.745	22.450	24.115	25.737	27.316	28.851	30.343	31.790	33.194	34.553
19.5	19.500	21.282	23.023	24.719	26.371	27.976	29.535	31.048	32.514	33.934	35.308
20.0	20.000	21.820	23.594	25.322	27.001	28.633	30.214	31.747	33.231	34.666	36.052
20.5	20.500	22.356	24.164	25.922	27.629	29.285	30.889	32.440	33.940	35.389	36.788
21.0	21.000	22.892	24.733	26.520	28.254	29.933	31.558	33.127	34.643	36.105	37.514
21.5	21.500	23.427	25.300	27.116	28.876	30.577	32.221	33.808	35.338	36.812	38.232
22.0	22.000	23.962	25.866	27.710	29.494	31.218	32.880	34.483	36.026	37.512	38.940
22.5	22.500	24.496	26.430	28.301	30.109	31.854	33.534	35.152	36.708	38.203	39.639
23.0	23.000	25.029	26.993	28.891	30.722	32.485	34.183	35.814	37.283	38.886	40.330
23.5	23.500	25.561	27.554	29.478	31.330	33.113	34.826	36.471	37.809	39.562	41.011
24.0	24.000	26.093	28.114	30.062	31.936	33.737	35.465	37.122	38.709	40.229	41.684
24.5	24.500	26.625	28.673	30.644	32.539	34.356	36.098	37.766	39.362	40.889	42.348
25.0	25.000	25.155	29.230	31.224	33.128	34.971	36.726	38.405	40.009	41.540	43.003
25.5	25.500	27.685	29.786	31.802	33.734	35.582	37.349	39.037	40.648	42.185	43.650
26.0	26.000	28.214	30.340	32.377	34.326	36.189	37.967	39.664	41.281	42.821	44.288
26.5	26.500	28.742	30.892	32.950	34.916	36.792	38.580	40.284	41.906	43.450	44.919
27.0	27.000	29.270	31.443	33.520	35.502	37.390	39.188	40.899	42.525	43.071	45.541
27.5	27.500	29.796	31.992	34.088	36.084	37.985	39.791	41.508	43.138	44.685	46.155
28.0	28.000	30.323	32.540	34.653	36.664	38.575	40.389	42.111	43.744	45.292	46.760

Nose wheel deflection angle (°)	X = 1.0	X = 1.1	X = 1.2	X = 1.3	X = 1.4	X = 1.5	X = 1.6	X = 1.7	X = 1.8	X = 1.9	X = 2.0
28.5	28.500	30.848	33.086	35.216	37.240	39.161	40.982	42.708	44.343	45.892	47.358
29.0	29.000	21.372	22.631	35.777	37.813	39.742	41.570	43.299	44.936	46.484	47.949
29.5	29.500	31.896	34.174	36.335	38.382	40.320	42.153	43.885	45.522	47.069	48.531
30.0	30.000	32.419	34.715	36.890	38.948	40.893	42.731	44.465	46.102	47.648	49.107
30.5	30.500	32.941	35.255	37.443	39.511	41.463	43.304	45.039	46.676	48.219	49.674
31.0	31.000	33.463	35.793	37.994	40.071	42.028	43.872	45.608	47.244	48.784	50.235
31.5	31.500	33.983	36.329	38.542	40.627	42.589	44.435	46.172	47.805	49.342	50.788
32.0	32.000	34.503	36.864	39.088	41.180	43.146	44.994	46.730	48.361	49.893	51.334
32.5	32.500	35.022	37.397	39.631	41.730	43.700	45.548	47.282	48.910	50.438	51.874
33.0	33.000	35.540	37.929	40.172	42.276	44.249	46.097	47.810	49.454	50.077	52.406
33.5	33.500	36.057	38.459	40.170	42.819	44.794	46.642	48.372	49.991	51.509	52.932
34.0	34.000	36.574	38.987	41.246	43.359	45.335	47.182	48.908	50.524	52.035	53.451
34.5	34.500	37.090	39.514	41.780	43.896	45.872	47.717	49.440	51.050	52.555	53.964
35.0	35.000	37.604	40.039	42.311	44.430	46.406	48.248	49.967	51.571	53.069	54.470
35.5	35.500	38.119	40.562	42.839	44.960	46.935	48.775	50.488	52.086	53.578	54.971
36.0	36.000	38.632	41.084	43.365	45.467	47.461	49.297	51.005	52.596	54.080	55.465
36.5	36.500	39.144	41.604	43.889	46.011	47.983	49.184	51.517	53.101	54.577	55.953
37.0	37.000	39.656	42.122	44.410	46.532	48.501	50.328	52.024	53.601	55.068	56.435
37.5	37.500	40.166	42.639	44.929	47.050	49.015	50.637	52.526	54.095	55.553	56.911
38.0	38.000	40.676	43.154	45.445	47.565	49.526	51.341	53.024	54.584	56.034	57.382
38.5	38.500	41.185	43.667	45.960	48.077	50.003	51.842	53.517	55.068	56.509	57.847
39.0	39.000	41.693	44.179	46.471	48.585	50.537	52.339	54.005	55.548	56.978	58.307
39.5	39.500	42.201	44.689	46.981	49.091	51.036	52.831	54.489	56.022	57.443	58.761
40.0	40.000	42.707	45.198	47.487	49.594	51.533	53.320	54.968	56.492	57.902	59.210
40.5	40.500	43.213	45.704	47.992	50.094	52.026	53.804	55.443	56.957	58.357	59.654
41.0	41.000	43.719	46.210	48.494	50.590	52.515	54.285	55.914	57.418	58.807	60.093
41.5	41.500	44.222	46.713	48.994	51.084	53.001	54.761	56.381	57.874	59.252	60.527
42.0	42.000	44.725	47.215	49.492	51.575	53.483	55.234	56.843	58.325	59.692	60.956
42.5	42.500	45.227	47.716	49.988	52.063	53.963	55.703	57.302	58.772	60.128	61.381
43.0	43.000	45.729	48.215	50.481	52.549	54.439	56.169	57.756	59.215	60.559	61.800
43.5	43.500	46.229	48.712	50.972	53.031	54.911	56.631	58.206	59.654	60.986	62.216
44.0	44.000	46.729	49.208	51.461	53.511	55.381	57.089	58.653	60.088	61.409	62.626
44.5	44.500	47.228	49.702	51.947	53.988	55.847	57.543	59.096	60.519	61.827	63.033
45.0	45.000	47.726	50.194	52.431	54.462	56.310	57.995	59.534	60.945	62.241	63.435
45.5	45.500	48.224	50.685	52.914	54.934	56.770	58.442	59.970	61.368	62.652	63.833
46.0	46.000	48.720	51.175	53.394	55.403	57.227	58.887	60.401	61.878	63.058	64.227
46.5	46.500	49.216	51.663	53.872	55.869	57.681	59.328	60.829	62.202	63.460	64.616
47.0	47.000	49.711	52.149	54.347	56.333	58.132	59.765	61.254	62.613	63.858	65.002
47.5	47.500	50.205	52.634	54.821	56.794	58.850	60.200	61.675	63.021	64.253	65.384
48.0	48.000	50.698	53.118	55.293	57.253	59.025	60.631	62.092	63.425	64.644	65.763
48.5	48.500	51.190	53.600	55.762	57.709	59.467	61.059	62.506	63.825	65.031	66.137
49.0	49.000	51.682	54.080	56.230	58.163	59.907	61.485	62.917	64.222	65.415	66.508
49.5	49.500	51.173	54.559	56.696	58.614	60.343	61.907	63.325	64.616	65.795	66.876
50.0	50.000	52.663	55.037	57.159	59.063	60.777	62.326	63.730	65.007	66.172	67.240
50.5	50.500	53.152	55.513	57.621	59.510	61.209	62.742	64.131	65.394	66.546	67.600
51.0	51.000	53.641	55.988	58.081	59.954	61.637	63.155	64.530	65.778	66.916	67.957
51.5	51.500	54.128	56.461	58.539	60.396	62.063	63.566	64.925	66.159	67.283	68.311
52.0	52.000	54.615	56.933	58.995	60.836	62.487	63.974	65.317	66.537	67.647	68.662
52.5	52.500	55.102	57.404	59.449	61.273	62.908	64.379	65.707	66.912	68.008	69.010
53.0	53.000	55.587	57.873	59.901	61.709	63.326	64.781	66.094	67.284	68.366	69.355
53.5	53.500	56.072	58.341	60.351	62.142	63.743	65.181	66.478	67.653	68.721	69.697
54.0	54.000	56.556	58.807	60.800	62.573	64.156	65.578	66.859	68.019	69.074	70.035
54.5	54.500	57.039	59.272	61.247	63.001	64.568	65.972	67.238	68.383	69.423	70.371
55.0	55.000	57.521	59.736	61.692	63.428	64.977	66.364	67.614	68.744	69.770	70.705
55.5	55.500	58.003	60.199	62.136	63.358	65.383	66.754	67.987	69.102	70.114	71.035
56.0	56.000	58.484	60.660	62.577	64.276	65.788	67.141	68.358	69.458	70.455	71.363
56.5	56.500	58.964	61.120	63.017	64.696	66.190	67.526	68.727	69.811	70.794	71.688
57.0	57.000	59.444	61.579	63.456	65.115	66.590	67.909	69.093	70.161	71.130	72.011

Nose wheel deflection angle (°)	X = 1.0	X = 1.1	X = 1.2	X = 1.3	X = 1.4	X = 1.5	X = 1.6	X = 1.7	X = 1.8	X = 1.9	X = 2.0
57.5	57.500	59.923	62.037	63.893	65.532	66.988	68.289	69.457	70.510	71.464	72.331
58.0	58.000	60.401	62.493	64.328	65.947	67.384	68.667	69.818	70.856	71.795	72.649
58.5	58.500	60.878	62.948	64.762	66.360	67.778	69.043	70.177	71.199	72.124	72.965
59.0	59.000	61.355	63.402	65.194	66.772	68.170	69.417	70.534	71.540	72.451	73.278
59.5	59.500	61.831	63.855	65.624	67.181	68.360	69.789	70.889	71.879	72.775	73.589
60.0	60.000	62.307	64.307	66.053	67.589	68.948	70.158	71.242	72.216	73.098	73.898
60.5	60.500	62.781	64.757	64.481	67.995	69.334	70.526	71.592	72.551	73.418	74.205
61.0	61.000	63.256	65.207	66.907	68.400	69.719	70.892	71.941	72.884	73.736	74.509
61.5	61.500	63.729	65.655	67.332	68.802	70.101	71.255	72.287	73.214	74.052	74.812
62.0	62.000	64.202	66.102	67.775	69.204	70.482	71.617	72.632	73.543	74.366	75.112
62.5	62.500	64.674	66.549	68.177	69.603	70.861	71.977	72.975	73.870	74.678	75.411
63.0	63.000	65.146	66.994	68.598	70.001	71.238	72.336	73.315	74.195	74.988	75.707
63.5	63.500	65.617	67.438	69.017	70.398	71.614	72.692	73.654	74.518	75.296	76.002
64.0	64.000	66.088	67.881	69.435	70.793	71.988	73.047	73.992	74.839	75.603	76.295
64.5	64.500	66.558	68.323	69.852	71.186	72.360	73.400	74.327	75.159	75.908	76.586
65.0	65.000	67.027	68.764	70.267	71.578	72.731	73.752	74.661	75.476	76.211	76.876
65.5	65.500	67.496	69.205	70.681	71.969	73.100	74.102	74.993	75.792	76.512	77.164
66.0	66.000	67.964	69.644	71.095	72.358	73.468	74.450	75.324	76.107	76.812	77.450
66.5	66.500	68.432	70.082	71.506	72.746	73.834	74.797	75.653	76.420	77.110	77.734
67.0	67.000	68.899	70.520	71.917	73.133	74.199	75.142	75.980	76.731	77.406	78.017
67.5	67.500	69.336	70.956	72.327	73.518	74.563	75.486	76.306	77.041	77.702	78.299
68.0	68.000	69.832	71.392	72.735	73.902	74.925	75.828	76.631	77.349	77.995	78.579
68.5	68.500	70.298	71.827	73.143	74.285	75.286	76.169	76.954	77.656	78.287	78.858
69.0	69.000	70.763	72.251	73.549	74.667	75.646	76.509	77.276	77.962	78.587	79.135
69.5	69.500	71.227	72.695	73.955	75.048	76.004	76.847	77.596	78.266	78.867	79.411
70.0	70.000	71.692	73.127	74.359	75.427	76.361	77.184	77.915	78.569	79.156	79.686
70.5	70.500	72.155	73.559	74.762	75.805	76.717	77.520	78.233	78.870	79.442	79.959
71.0	71.000	72.619	73.900	75.165	76.182	77.072	77.855	78.550	79.171	79.728	80.232
71.5	71.500	73.081	74.420	75.566	76.559	77.425	78.188	78.865	79.470	80.012	80.503
72.0	72.000	73.544	74.850	75.967	76.934	77.778	78.521	79.180	79.768	80.296	80.772
72.5	72.500	74.006	75.278	76.367	77.309	78.129	78.852	79.493	80.065	80.578	81.041
73.0	73.000	74.467	75.707	76.766	77.681	78.480	79.182	79.805	80.360	80.859	81.309
73.5	73.500	74.929	76.134	77.164	78.053	78.829	79.511	80.116	80.655	81.139	81.575
74.0	74.000	75.389	76.561	77.561	78.425	79.178	79.840	80.426	80.949	81.418	81.841
74.5	74.500	75.850	76.987	77.958	78.795	79.525	80.167	80.735	81.241	81.696	82.106
75.0	75.000	76.310	77.413	78.354	79.165	79.872	80.493	81.043	81.533	81.973	82.369
75.5	75.500	76.770	77.838	78.749	79.534	80.218	80.818	81.350	81.824	82.249	82.632
76.0	76.000	77.229	78.262	79.143	79.902	80.563	81.143	81.656	82.114	82.524	82.894
76.5	76.500	77.688	78.686	79.537	80.269	80.907	81.466	81.962	82.403	82.798	83.155
77.0	77.000	78.147	79.110	79.930	80.636	81.250	81.789	82.266	82.691	83.072	83.415
77.5	77.500	78.605	79.533	80.322	81.002	81.593	82.111	82.570	82.979	83.345	83.675
78.0	78.000	79.063	79.955	80.714	81.367	81.935	82.433	82.873	83.265	83.617	83.933
78.5	78.500	79.521	80.377	81.105	81.731	82.276	82.753	83.175	83.551	83.888	84.192
79.0	79.000	79.979	80.799	81.496	82.095	82.616	83.073	83.477	83.837	84.159	84.449
79.5	79.500	80.436	81.220	81.886	82.459	82.956	83.392	83.778	84.121	84.429	84.706
80.0	80.000	80.893	81.641	82.276	82.822	83.296	83.711	84.078	84.405	84.698	84.962
80.5	80.500	81.350	82.061	82.665	83.184	83.634	84.029	84.378	84.689	84.967	85.217
81.0	81.000	81.807	82.481	83.054	83.545	83.972	84.347	84.677	84.971	85.235	85.472
81.5	81.500	82.263	82.901	83.442	83.907	84.310	84.664	84.976	85.254	85.502	85.726
82.0	82.000	82.719	83.320	83.830	84.287	84.647	84.980	85.274	85.536	85.770	85.980
82.5	82.500	83.175	83.739	84.217	84.628	84.984	85.296	85.572	85.817	86.036	86.234
83.0	83.000	83.631	84.156	84.604	84.988	85.320	85.612	85.869	86.098	86.302	86.487
83.5	83.500	84.087	84.576	84.991	85.347	85.656	85.927	86.166	86.378	86.568	86.740
84.0	84.000	84.542	84.994	85.378	85.707	85.992	86.242	86.462	86.658	86.834	86.992
84.0	84.000	84.542	84.994	85.378	85.707	85.992	86.242	86.462	86.658	86.834	86.992
84.5	84.500	84.997	85.412	85.764	86.066	86.327	86.556	86.758	86.938	87.099	87.244
85.0	85.000	85.453	85.830	86.150	86.424	86.662	86.870	87.054	87.217	87.364	87.495
85.5	85.500	85.908	86.248	86.536	86.782	86.997	87.184	87.349	87.496	87.628	87.747

Appendix 2

JET BLAST AND BLAST FENCE CONSIDERATIONS

Introduction

1. “Jet blast” and “prop wash” are terms used to describe the air currents that emanate from the operation of jet and propeller engines, respectively. The design of ground facilities, buildings and pavements must take into account the impact of the forces that result from these air movements. Prior to the introduction of jet turbine engines, very little attention was focused, when planning facilities and pavements, on the detrimental effects of propeller wash. Service and maintenance areas were sometimes equipped with fences to deflect winds because of the close aircraft spacings used in these areas, but the design of aprons and terminal buildings was generally not influenced by propeller wash considerations. The introduction of the jet engine and the technological improvements that have been made towards increasing the power and efficiency of these engines have brought about a significant increase in blast velocities and, therefore, the need to design facilities to accommodate the wind forces associated with these velocities. This appendix describes the nature of these forces in terms of their magnitude and location and presents concepts in the location and design of blast fences and pavements which may be required at aerodromes to mitigate these wind forces.

Related effects

2. In addition to high wind velocities, the noise, heat and fumes from jet engine exhaust should also be anticipated when planning aerodrome facilities. However, the areas where the effects of jet engine exhaust are detrimental to personnel or buildings are usually unoccupied because of the high blast air velocities. The potential for sand, gravel or other loose objects to become projectiles and be thrown for great distances or drawn into engines must be mitigated. Such flying objects can injure personnel and damage equipment, facilities and other aircraft.

Design thrust levels

3. Three levels of engine thrust are commonly used to determine the critical velocities for use in building and pavement design: idle thrust, breakaway thrust and maximum continuous thrust (take-off thrust). Nearly all facilities adjacent to aircraft movement areas will be subjected to at least idle thrust from the engines on the critical design aircraft. Breakaway thrust is the level of thrust needed to initiate aircraft taxi movement and is generally 50 to 60 per cent of maximum continuous thrust. Areas typically designed for breakaway thrust may include terminal buildings, apron and taxiway shoulders, holding bays and all pavements except for the runways. Aircraft use maximum continuous thrust during take-off, and thus the runway pavement, shoulders and ends (blast pads) would be designed for this thrust level.

Threshold velocities

4. Jet blast velocities above 56 km/hr are considered to be undesirable for personal comfort or for the operation of vehicles or other equipment on the movement area. Buildings can be designed to withstand much higher velocities, but the extra cost of construction needed to handle wind pressures above those normally used in building design may become prohibitive. Buildings are normally designed to handle winds of 130-200 km/hr, depending upon locality. If design velocities are increased above this level because of blast, then the building structural frame and architectural facades will need to be strengthened accordingly. The trade-off between increasing the cost of the building and other solutions to lower the blast velocities striking the building (such as erecting blast fences or increasing the apron size) must be examined for any given aerodrome.

BLAST VELOCITIES AND PRESSURES

Velocity curves

5. Figures A2-1 through A2-4 present velocity curves for the Douglas DC8, Boeing B727, Boeing B747 and Douglas DC10. Each graph has curves of velocity versus distance for the three design thrust levels. It has been determined from various studies that blast velocities are cyclical with velocity peaks occurring two to six times per second. These peaks are not continuous laterally or vertically and cover relatively small areas. The maximum velocities shown in all figures are an average of the peaks. Information on specific jet engine exhaust velocities, including lateral and vertical contours, for a given aircraft model is given in the Airplane Characteristics For Airport Planning document (NAS 3601) prepared for most aircraft models by the aircraft manufacturer. These documents are generally available from the manufacturers upon written request. Lateral and vertical contours for the DC8, B727, B747 and DC10 at breakaway and take-off power are shown in Figures A2-5 through A2-8.

Comparative velocities

6. Table A2-1, prepared from Figures A2-1 through A2-4, shows the distance from the rear of an aircraft at which the blast velocity has been reduced to 56 km/hr, the threshold for personal comfort, operation of vehicles or other equipment, for each of the four commercial aircraft types and thrust levels.

7. The older generation DC8 and B727 have similar velocity characteristics, though the B727 idles with greater thrust but has much less thrust at breakaway. The long-bodied B747 and DC10 aircraft confirm the trend mentioned previously that technological improvements have greatly increased the problem of jet blast. Each requires two or three times as much distance behind the aircraft to reduce the velocity to personal comfort levels than for the other two aircraft types. Table A2-2 presents the blast velocities at 15 m and 30 m from the rear of the aircraft for the same commercial aircraft and for a group of business jet aircraft.

8. It is worth noting that while the blast velocity levels for the business jets shown are of the same magnitude as the commercial jets, the size of the area subjected to these blast velocities is much smaller for the business jets. Additionally, the blasts from the smaller jets — the B727 and the four business jets — fall off more rapidly with distance as the blast-generated winds spread out quickly from the smaller jet engines on these aircraft.

Blast pressure

9. The forces generated by jet blast can be calculated using formulae of the general wind pressure form $P = C \times V^2$, where P is the pressure, C is a shape factor and V^2 is the square of the wind velocity normal to the surface. Figure A2-9 presents a graph of pressure versus blast velocity and includes the general formula in terms of the units given for velocity and pressure. The upper curve gives the pressure on a flat surface oriented perpendicular

Table A2-1. Distance at which blast velocity has been reduced to 56 km/hr

Aircraft type	Idle thrust (m)	Breakaway thrust (m)	Take-off thrust (m)
DC8	6	79	160
B727	29	49	130
B747	76	250	410
DC10	64	180	460
A380	N/A	N/A	N/A

Table A2-2. Blast velocity levels

Aircraft type	Blast velocity at 15 m			Blast velocity at 30 m		
	Idle (km/hr)	Breakaway (km/hr)	Take-off (km/hr)	Idle (km/hr)	Breakaway (km/hr)	Take-off (km/hr)
Commercial jets						
DC8	29	122	210	14	96	161
B727	106	193	530	53	96	290
B747	74	164	320	67	143	260
DC10	116	260	610	85	177	420
Business jets						
Lear-Commander	47	95	215	21	43	98
Falcon	72	137	305	43	64	146
Sabreliner	79	162	370	35	74	169
Gulfstream-II	145	297	675	80	141	320

to the direction of the blast which yields the greatest possible pressure. The lower curve is for a more aerodynamically shaped surface with a shape factor coefficient 70 per cent as great as the flat surface coefficient. The total force on a curved surface is found by multiplying the pressure by the area of the surface projected onto a plane perpendicular to the direction of the blast. Because pressure is a function of the square of the velocity, a doubling of velocity causes a quadrupling of pressure. On the other hand, a relatively small increase in the distance between the rear of an aircraft and buildings, equipment or personnel will yield a significant reduction in the pressure exerted by the blast on the object. Also shown on Figure A2-9 are representative blast velocities from Table A2-2 to show the relationship with the personal comfort level and the typical building design wind pressure.

- b) the height of the centre line of blast depends upon the height and angle of the engines on the aircraft;
- c) except for long-bodied aircraft, the lateral spread of blast winds is generally confined within the wing tips of the aircraft for a significant distance behind the aircraft (see notes on Figures A2-1 through A2-4); and
- d) ambient winds can increase, decrease or shift the engine blast, depending upon the direction of the wind. Allowance can be made for this factor by adding an ambient wind velocity (appropriate for a given locality) to the blast velocity.

Other considerations

10. Several additional factors which further define the nature of blast are as follows:

- a) jet blast is irregular and turbulent in nature. When designing windows and elements of buildings less than 1.4 m, the vibrations caused by the cyclical nature of blast velocities should be taken into account;

BLAST FENCES

Application

11. Blast fences are used at aerodromes to reduce or eliminate the detrimental effects of blast by deflecting the high air velocities, heat, fumes and noise associated with blast. The application of either fences or screens becomes necessary when it is impractical to provide a safe,

reasonable separation between aircraft engines and people, buildings or other objects on the aerodrome. Aerodrome locations requiring blast fences are indicated in Figure A2-10.

Planning criteria

12. The aircraft types and their possible movement patterns must be established when planning a system of blast fences for a new or existing aerodrome. Each segment of the aircraft movement area, including the aprons, taxiways, holding bays and runways, must be analysed to determine the magnitude and all possible orientations for blast in that particular location. For a new aerodrome, this information can be used as one of the many criteria needed to determine appropriate building restriction lines for the location of future facilities. For an existing aerodrome, this information can be used to determine where new blast fences should be located or modified because of the introduction of larger jets, the addition of new runways or taxiways, or a change in aircraft ground movement patterns.

Blast fences in apron areas

13. The type of apron movement pattern used by aircraft entering or exiting aircraft stands is a critical factor in determining the need for and location of blast fences. Figure A2-11 illustrates an example of the fence requirements for a self-maneuvring aircraft stand and for the same stand using a taxi-in, push-out procedure. Because the aircraft on this self-maneuvring stand must make a full 180° turn within the apron area under breakaway blast conditions, all areas along the public access road, service road and between aircraft parking positions can be subjected to excessive blast. As a result, fences will be required in all of these locations unless sufficient separation can be provided between the aircraft positions and the affected area. The situation becomes more complicated if passengers must walk on the apron to board the aircraft. Additional precautions may be required to protect them from the blast of aircraft entering or leaving adjacent stands. Had the apron been designed so as to use a nose-in, push-out procedure and nose-loading devices, only a blast fence along the public access road would be needed. This type of apron system has become more common at larger aerodromes serving the latest generation of jets because of the increasing problem with blast in the newer jets and the need to reduce the cost and complexity of accommodating blast on self-maneuvring stands.

Blast fences in off-apron areas

14. Blast fences should also be used anywhere on an aerodrome where blast could cause a danger to personnel or inflict damage to buildings, equipment or other aircraft. They are often used along taxiways and near taxiway cross-overs to protect hangars or terminal facilities where the aircraft can turn through 90 or 180 degrees. Another critical location is the area off the end of the runway, centred about the runway centre line, which should be examined closely because this area is subjected to the aircraft's maximum continuous thrust on take-off. Roads or railways intersecting these areas may need the protection of blast fences. Of course the use of blast fences in any location should not cause a hazard to the movement of aircraft or ground vehicles (see Figure A2-11).

Other types of blast protection

15. Although the use of manufactured blast fences is effective, blast protection may be gained using other methods and materials. Any obstruction, either natural or constructed, will afford some level of protection. Hedges, bushes and trees can also help attenuate sound. Tall hedges may be used with great advantage in some cases such as around engine run-up areas.

DESIGN OF BLAST FENCES

16. Though often vital to the safe operation of an aerodrome, blast fences are rarely the starting point in the design of apron or aerodrome facilities. Instead, they are located only after the basic aerodrome layout has been determined and where it is most convenient with regard to aircraft or ground vehicle movements. In addition, the appearance of the fences will often be dictated by overall architectural considerations. For these reasons, the design of blast fences is difficult to standardize and often requires custom design.

Types of fencing

17. Fencing material can be either concrete or metal. Most premanufactured fences are metal. Concrete deflectors generally require much less maintenance. Louvred fences deflect the blast through their full height and therefore are subjected to lower wind forces than a solid fence for the same blast conditions. Baffles, perforations, louvres and corrugations can be used singly or in combination to most effectively reduce or eliminate blast effects behind the

fence. Several types of blast fences are illustrated in Figure A2-12.

Structural design of blast fences

18. Both custom-designed and premanufactured blast fences require a thorough structural analysis to ensure that the fence used has adequate strength to carry the wind forces. The procedures which would be used in a typical design are summarized in the following paragraphs.

- a) *Gross wind pressure.* For a given fence location, the worst possible blast velocity from the aircraft to be served at the aerodrome can be determined by referring to blast velocity-versus-distances curves such as Figures A2-1 through A2-4. The blast pressure can be determined by converting wind velocity to pressure using Figure A2-9.
- b) *Height of fence.* The blast fence should, at a minimum, be high enough to deflect the centre portion of the blast. This height is an aircraft-dependent variable and should be used in conjunction with the calculation of pressure to establish the critical fence section.
- c) *Shape and type of fence.* The shape of the fence, whether curved, straight, angled or vertical, and the type of fence, such as solid or louvered, will determine the net wind pressure on the wall. Aerodynamically designed shapes and the use of openings in the fences will reduce the gross pressure requirements.
- d) *Analysis of forces.* Given the net pressure on the wall, its height, the location of other supports such as braces or struts, and the type of materials used, the sizes and strengths of the members required for the wall can be determined. This procedure applies to premanufactured fence sections as well as custom-designed sections.
- e) *Foundations.* The size and shape of the supporting foundation will depend on the factors listed in d) as well as the type of soils present in the area. Therefore, foundations, by necessity, are custom-designed.

BLAST PADS AND SHOULDERS

19. Shoulders adjacent to taxiways and runways and particularly the areas off the ends of the runways may be

subjected to large blast forces. In fact, drag and uplift forces, caused by high-energy jet exhaust from turbine-engined aircraft, at 10.5 m behind the exhaust nozzle of an engine operating at maximum thrust, can raise boulders 0.6 m in diameter completely off the ground. The forces causing such erosion decrease rapidly with distance; beyond about 360 m from the engine of a long-bodied aircraft, they affect only sand and finer cohesionless soils. Blast pads and shoulder paving should be used as needed to mitigate the detrimental effects of these factors. Guidance on treatment of shoulders and blast pads is given in Chapter 1, 1.6.9.

Dimensions

20. Blast pads should have a width equal to the width of the runway plus shoulders. The length of blast pads may be determined as follows:

- For aircraft such as Boeing 747 and A380, a blast pad length of at least 120 m is recommended;
- For smaller aircraft, a blast pad length of 60 m is recommended.

Drainage

21. Drainage capability should be maintained or improved in the affected areas. Where pavement edge drop-off and five per cent transverse slope are present in existing turf areas, they may be retained in the new paved surface. It is recommended that courses of sufficient depth be provided to maintain the positive drainage of granular base or sub-base courses under the runway pavement. An alternative is the provision of subdrains at the pavement edge. A sufficient number of manholes should be provided in the subdrains to permit observation and flushing of the subdrain system. Manhole covers should be capable of withstanding the superimposed loads.

Special conditions

22. It is recognized that local conditions at some aerodrome sites may require additional surface protection from erosion. In those circumstances, it is recommended that additional pavement be provided. The pavement section and surface material to be used should be governed by past satisfactory local experience. In approving low-cost materials and procedures, maintenance time should be considered, particularly for areas adjacent to critical-use “operational areas” or “taxiways.”

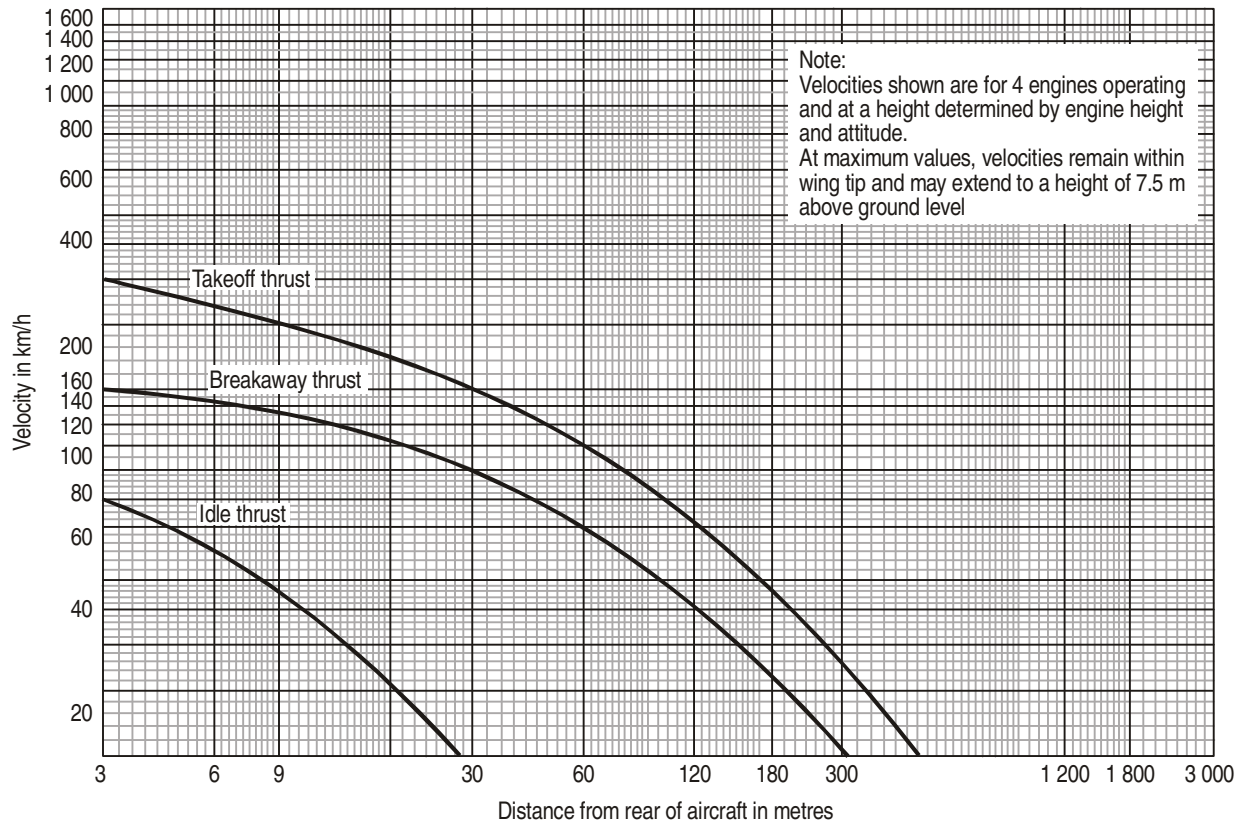

Figure A2-1. Maximum velocity curves (DC8)

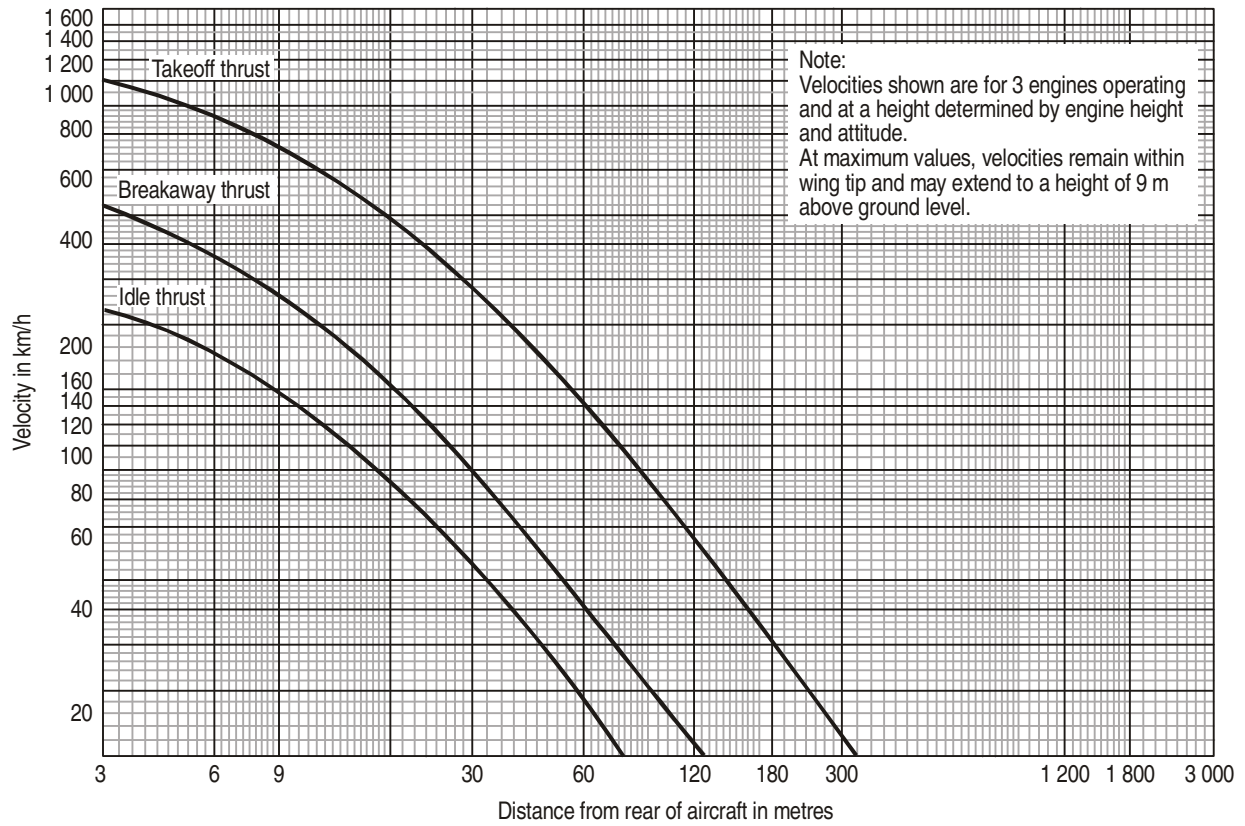

Figure A2-2. Maximum velocity curves (B727)

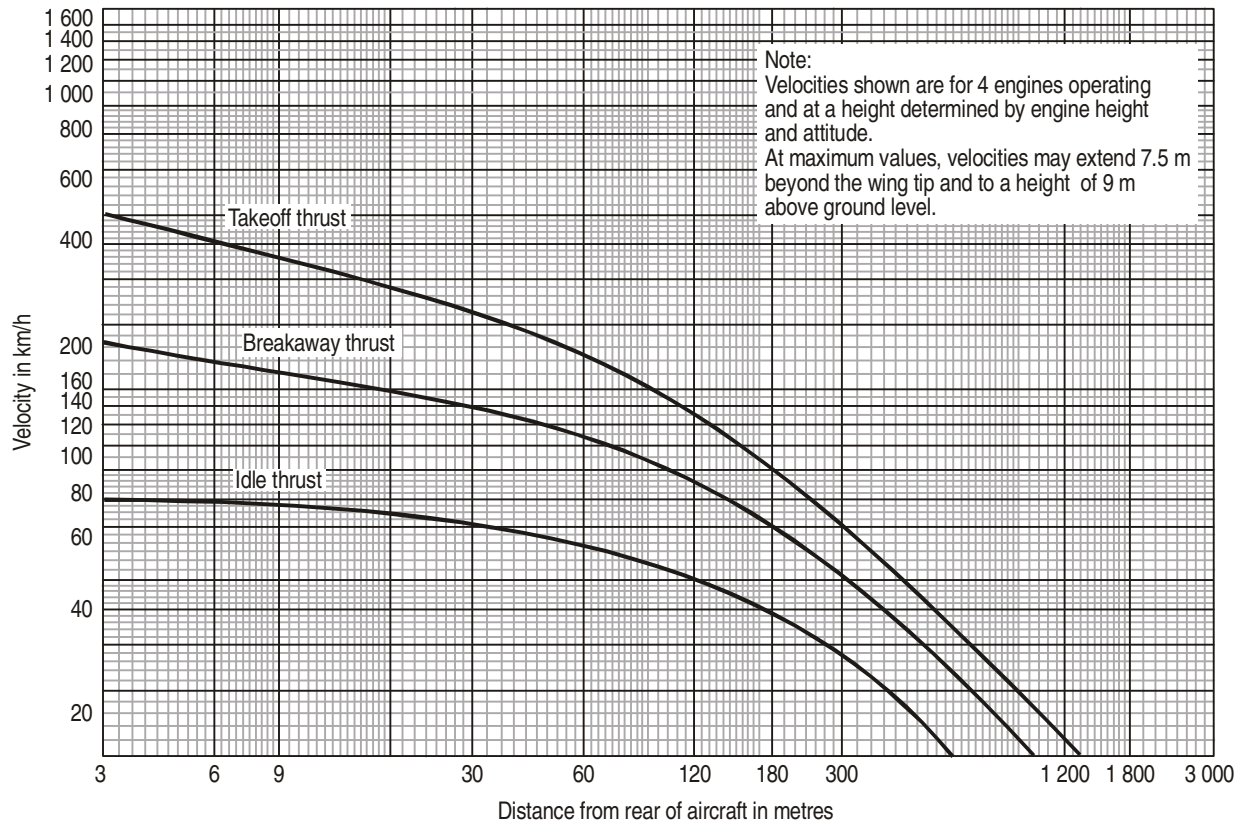

Figure A2-3. Maximum velocity curves (B747)

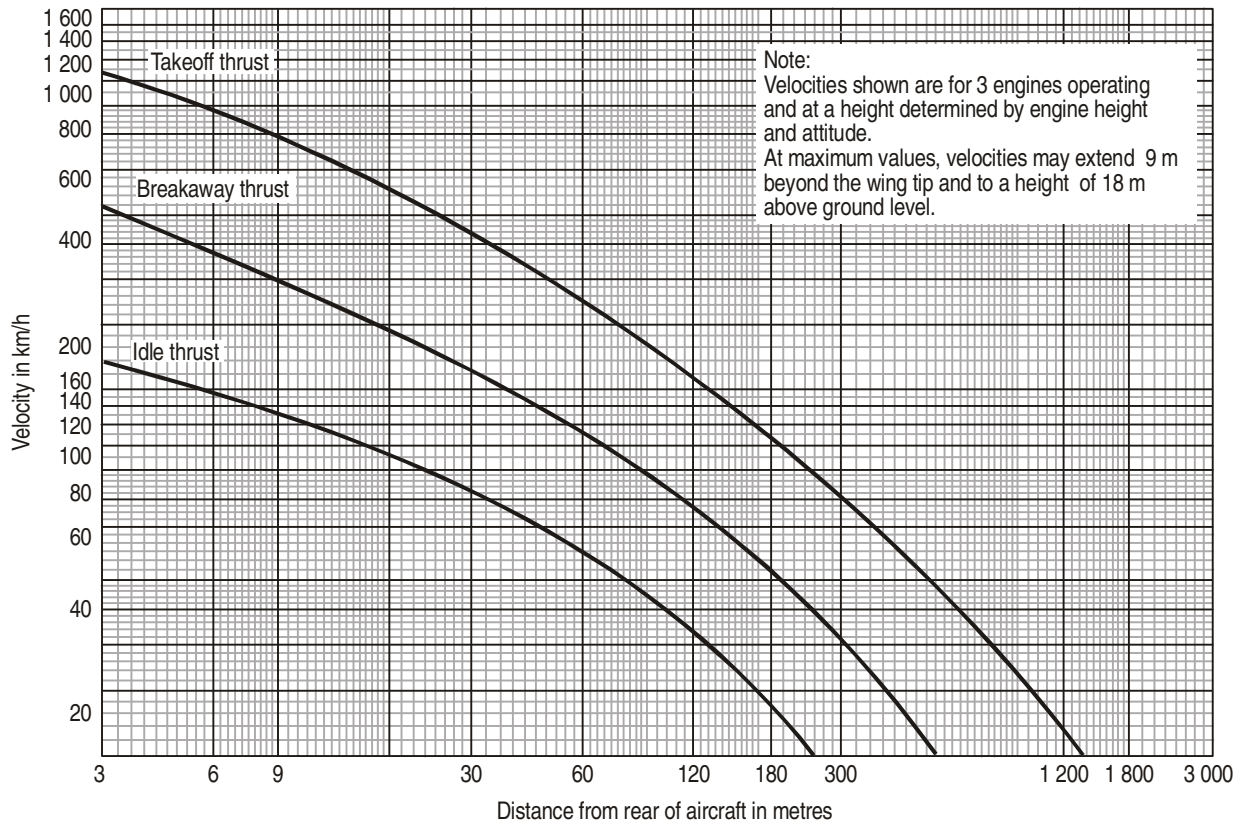

Figure A2-4. Maximum velocity curves (DC10)

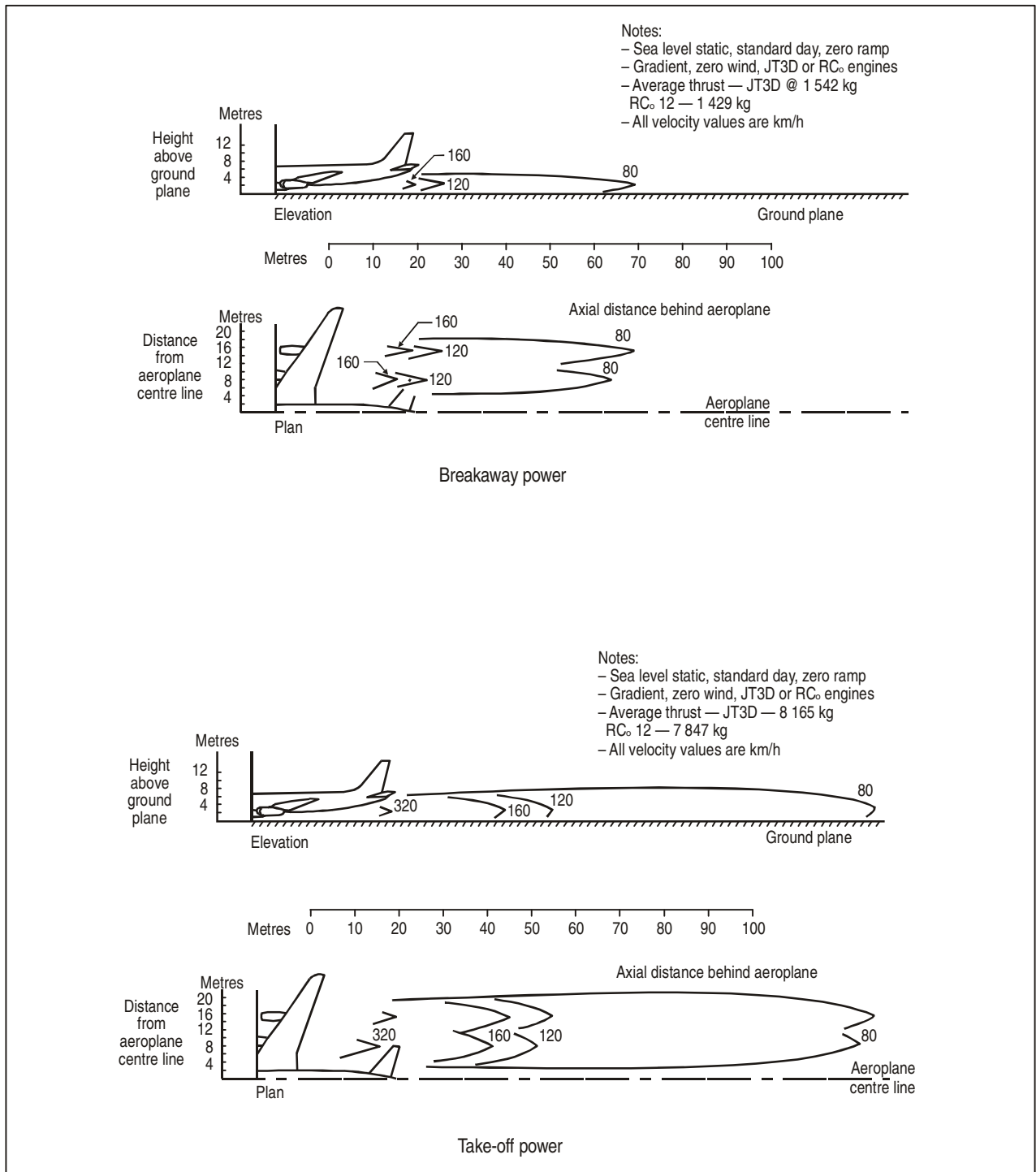

Figure A2-5. Jet engine exhaust velocity contours — McDonnell Douglas model DC8

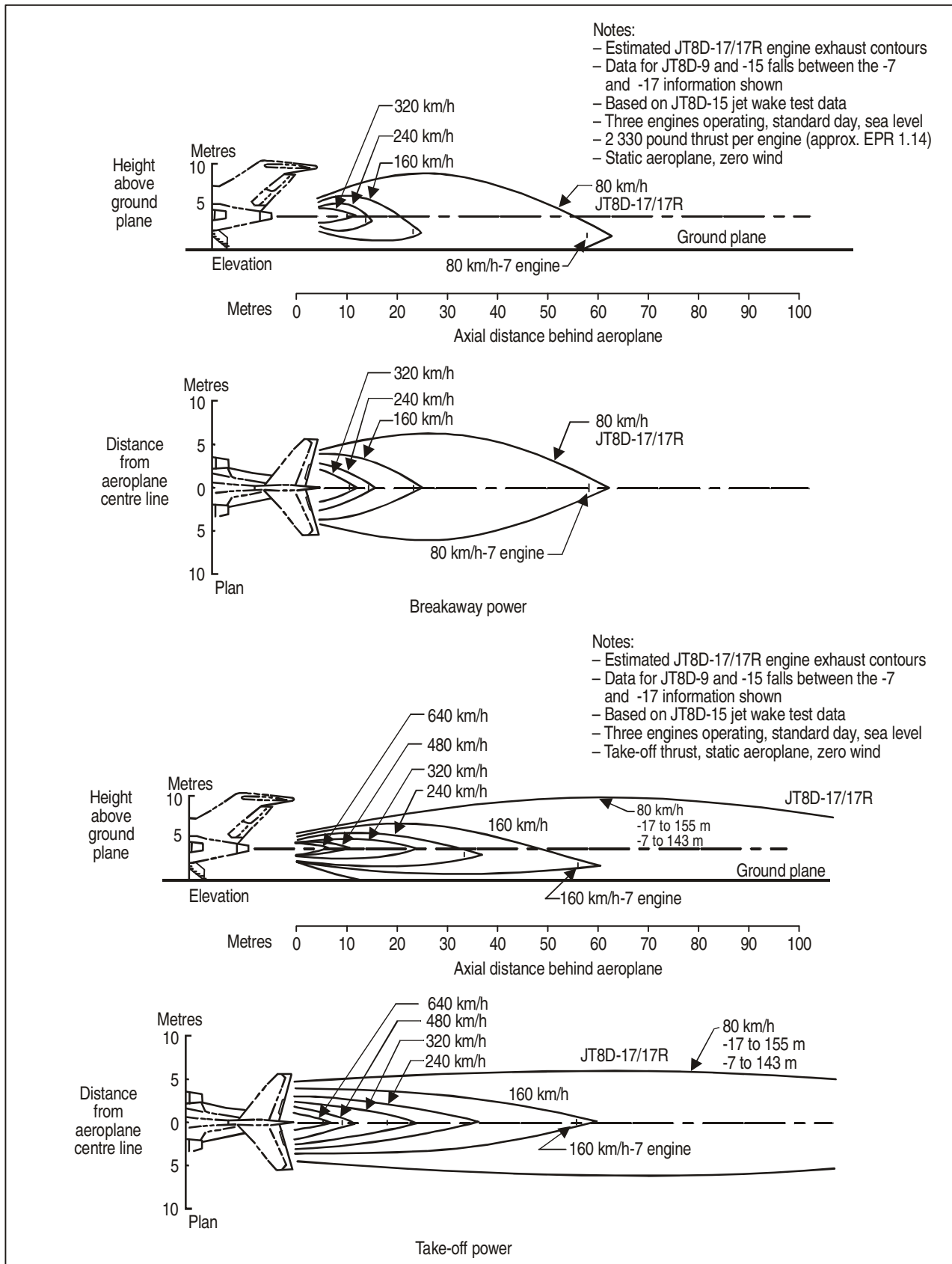

Figure A2-6. Jet engine exhaust velocity contours — Boeing model 727

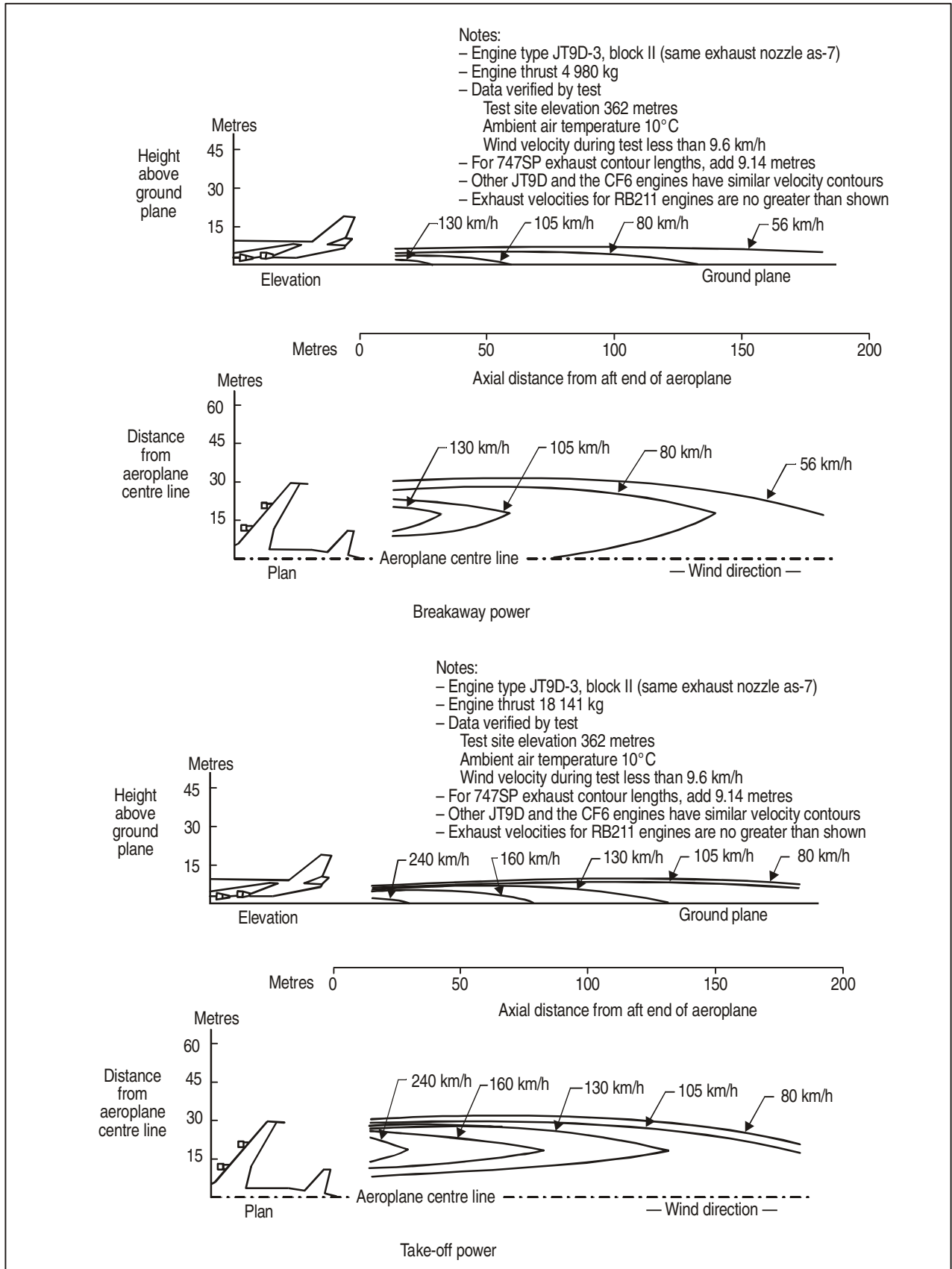

Figure A2-7. Jet engine exhaust velocity contours — Boeing model 747

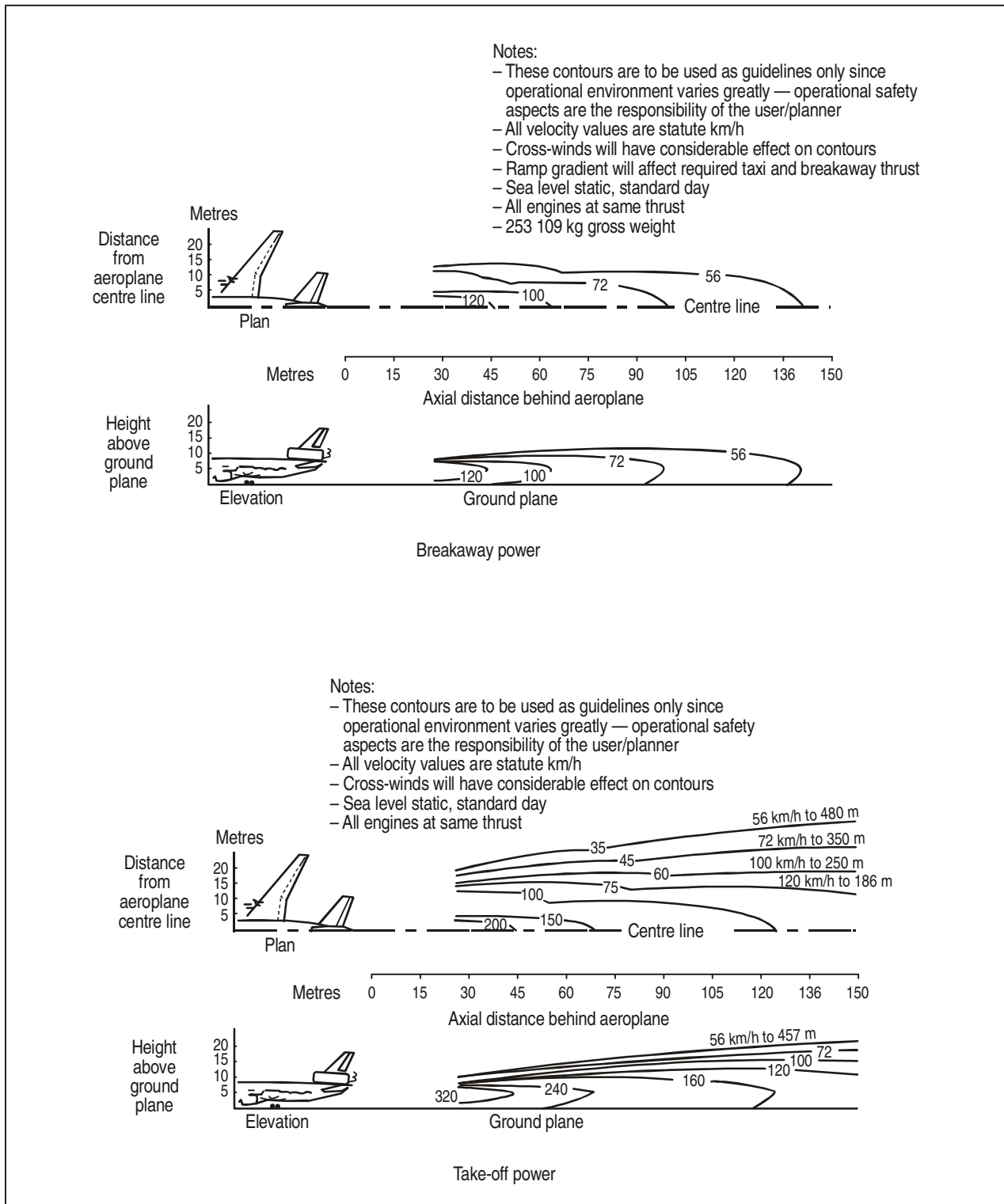

Figure A2-8. Jet engine exhaust velocity contours
 McDonnell Douglas model DC10

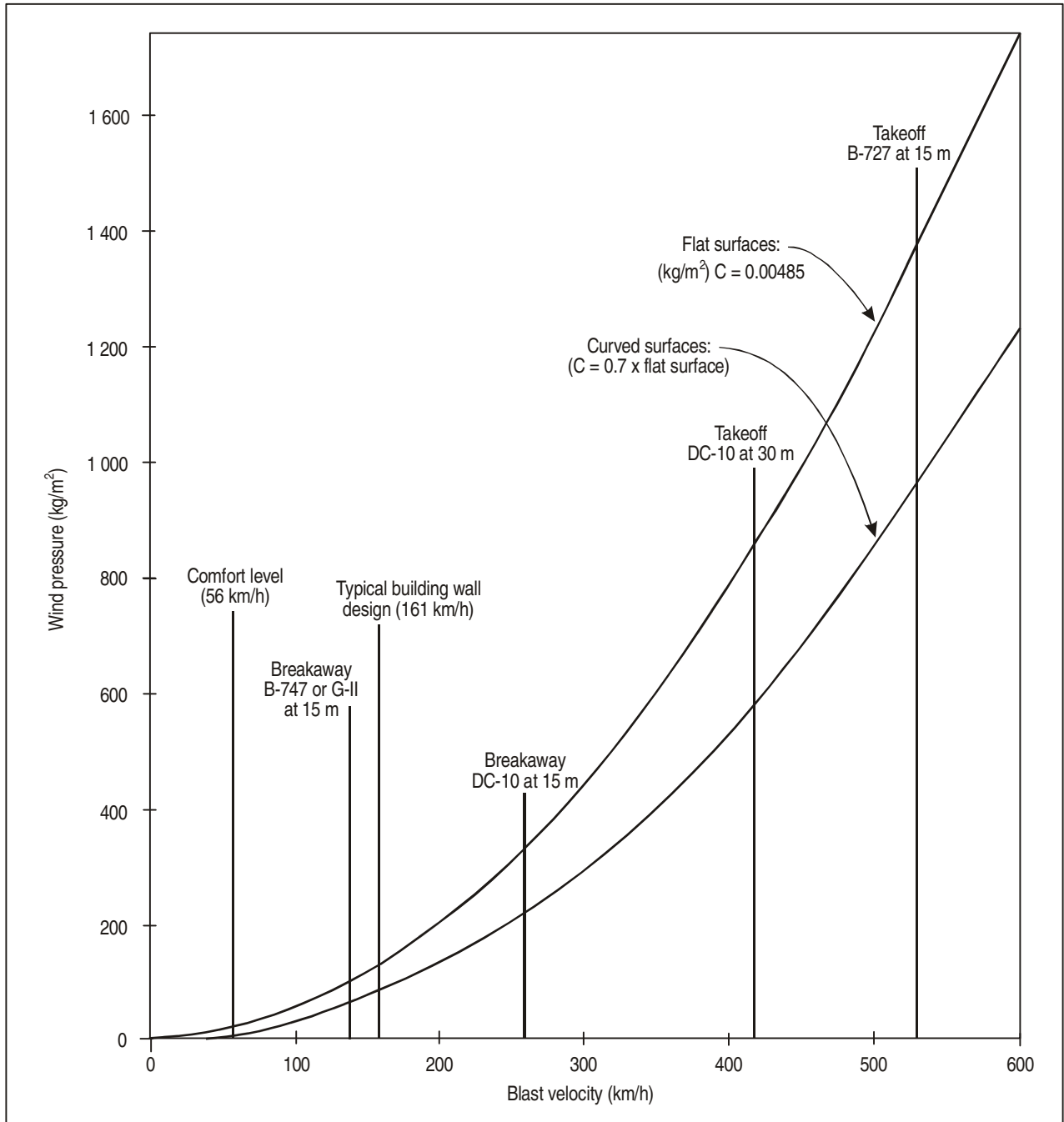

Figure A2-9. Wind pressure versus blast velocity

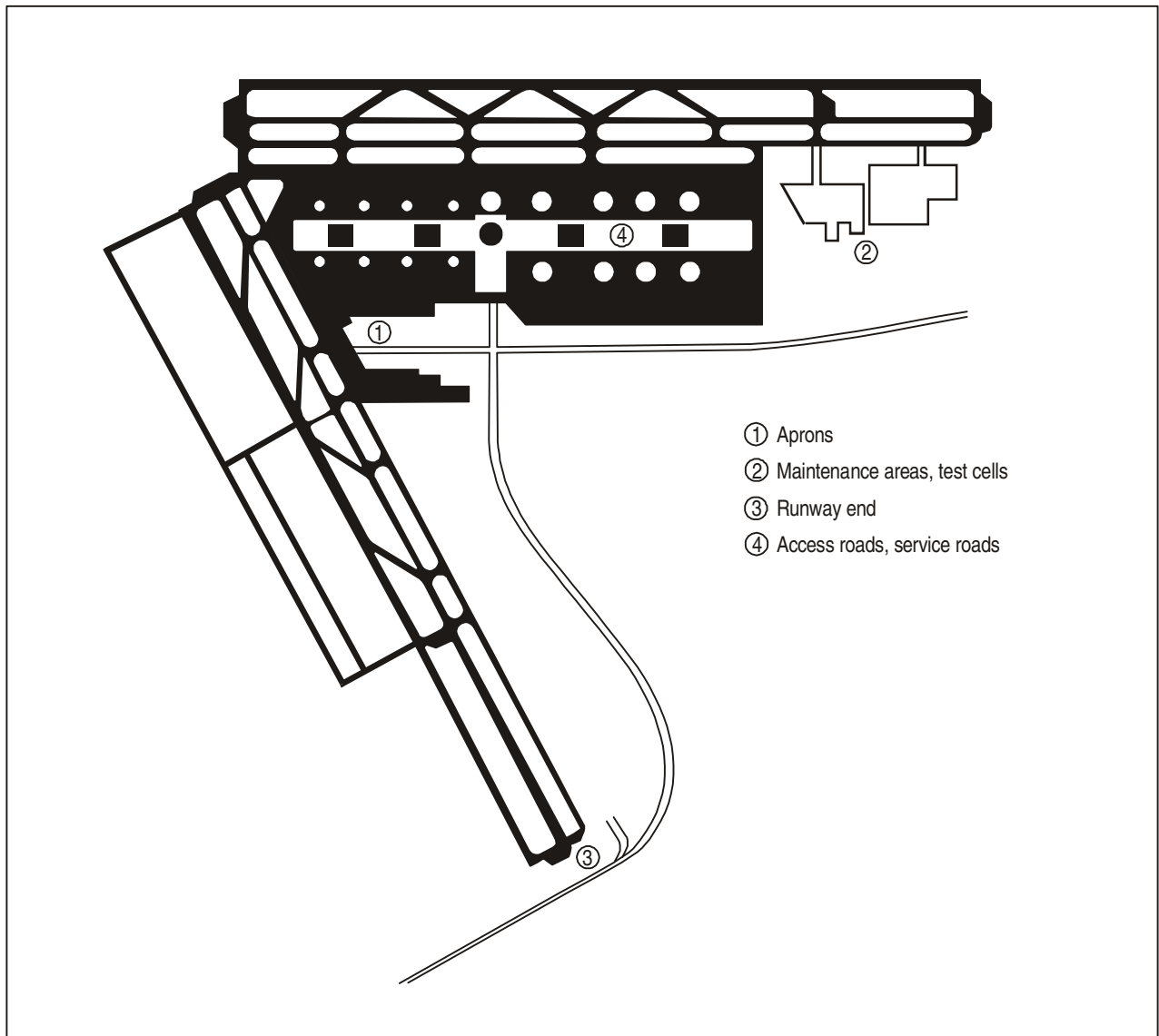

Figure A2-10. Aerodrome locations requiring blast fences

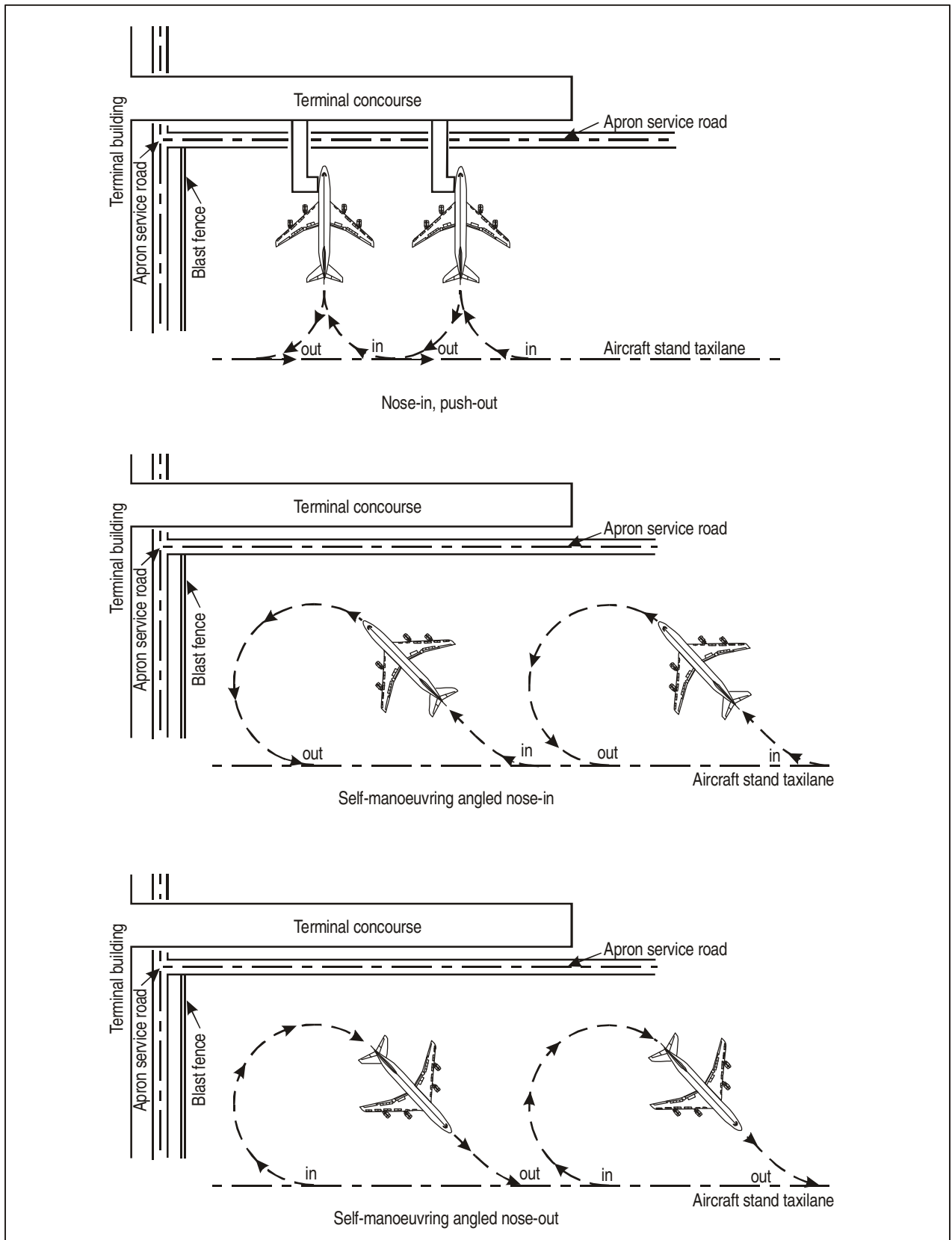

Figure A2-11. Blast fences in apron areas

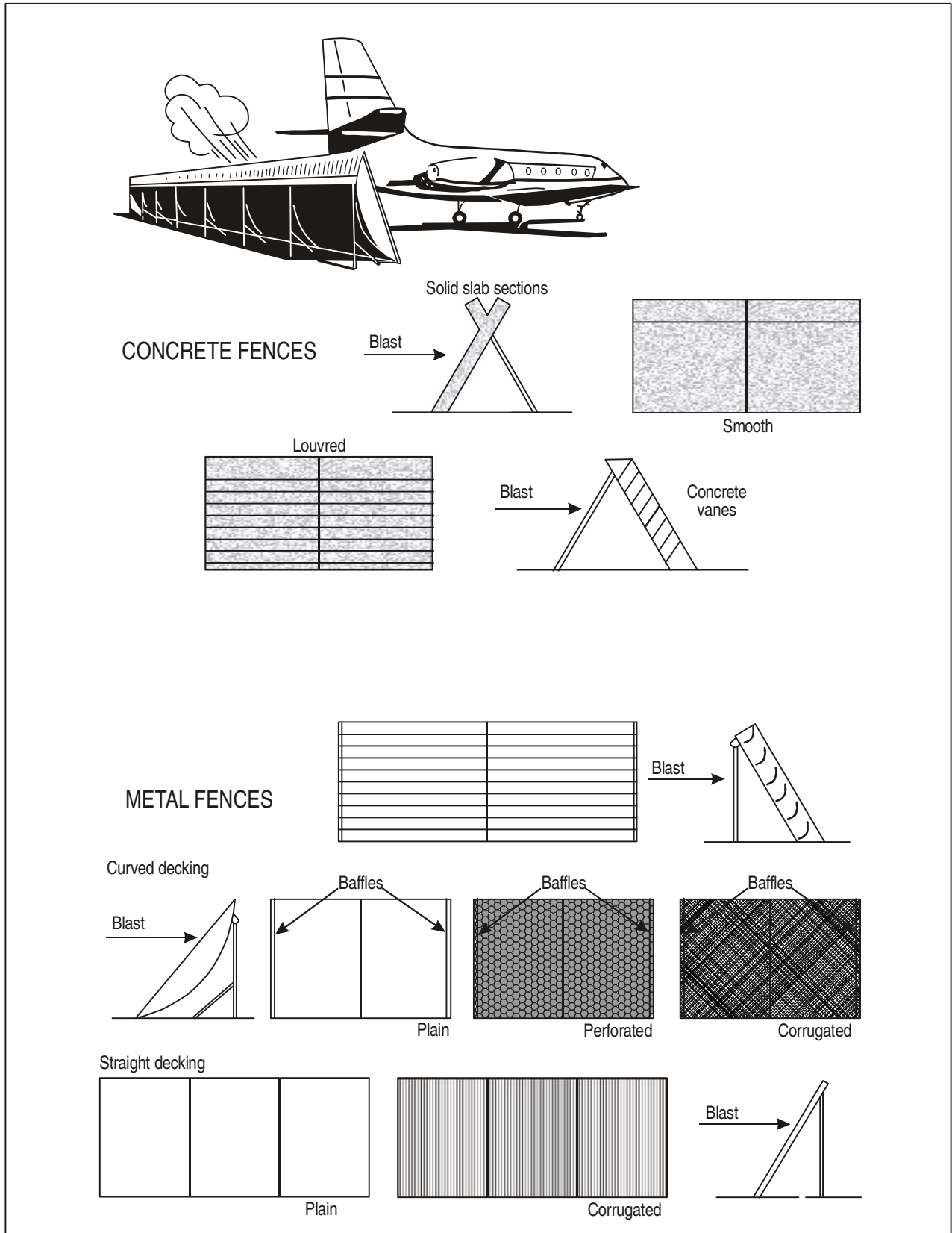

Figure A2-12. Types of blast fences

Appendix 3

AEROPLANE CLASSIFICATION BY CODE NUMBER AND LETTER

Aircraft Make	Model	Code	Aeroplane reference field length (m)	Wing span (m)	Outer main gear wheel span (m)
DeHavilland Canada	DHC2	1A	381	14.6	3.3
	DHC2T	1A	427	14.6	3.3
Britten Norman	BN2A	1A	353	14.9	4.0
Cessna	152	1A	408	10.0	—
	172 S	1A	381	11.0	2.7
	180	1A	367	10.9	—
	182 S	1A	462	11.0	2.9
	Stationair 6	1A	543	11.0	2.9
	Turbo 6	1A	500	11.0	2.9
	Stationair 7	1A	600	10.9	—
	Turbo 7	1A	567	10.9	—
	Skylane	1A	479	10.9	—
	Turbo Skylane	1A	470	10.9	—
	310	1A	518	11.3	—
	310 Turbo	1A	507	11.3	—
	Golden Eagle 421 C	1A	708	12.5	—
	Titan 404	1A	721	14.1	—
	Piper	PA28-161	1A	494 ¹	10.7
PA28-181		1A	490 ¹	10.8	3.2
PA28R-201		1A	487 ¹	10.8	3.4
PA32R-301		1A	539 ¹	11.0	3.5
PA32R-301T		1A	756 ¹	11.0	3.5
PA34-220T		1A	520 ¹	11.9	3.5
PA44-180		1A	671 ¹	11.8	3.2
PA46-350P		1A	637 ¹	13.1	3.9
Raytheon/Beechcraft		A24R	1A	603	10.0
	A36	1A	670	10.2	2.9
	76	1A	430	11.6	3.3
	B55	1A	457	11.5	2.9
	B60	1A	793	12.0	3.4
	B100	1A	579	14.0	4.3
Cessna	525	1B	939	14.3	4.1
DeHavilland Canada	DHC3	1B	497	17.7	3.7
	DHC6	1B	695	19.8	4.1
LET	L410 UPV	1B	740	19.5	4.0
Pilatus	PC-12	1B	452	16.2	4.5

Aircraft Make	Model	Code	Aeroplane reference field length (m)	Wing span (m)	Outer main gear wheel span (m)
Raytheon/Beechcraft	E18S	1B	753	15.0	3.9
	B80	1B	427	15.3	4.3
	C90	1B	488	15.3	4.3
	200	1B	579	16.6	5.6
Short	SC7-3/ SC7-3A	1B	616	19.8	4.6
DeHavilland Canada	DHC7	1C	689	28.4	7.8
Lear Jet	24F	2A	1 005	10.9	2.5
	28/29	2A	912	13.4	2.5
LET	L410 UPV-E	2B	920	20.0 ²	4.0
	L410 UPV-E9	2B	952	20.0 ²	4.0
	L410 UPV-E20	2B	1 050	20.0 ²	4.0
	L420	2B	920	20.0 ²	4.0
Shorts	SD3-30	2B	1 106	22.8	4.6
Dassault Aviation	Falcon 10	3A	1 615	13.1	3.0
Hawker Siddley	HS 125-400	3A	1 646	14.3	3.3
	HS 125-600	3A	1 646	14.3	3.3
	HS 125-700	3A	1 768	14.3	3.3
	Lear Jet	24D	3A	1 200	10.9
Lear Jet	35A/36A	3A	1 287/1 458	12.0	2.5
	54	3A	1 217	13.4	2.5
	55	3A	1 292	13.4	2.5
	Bombardier Aero.	CRJ 100	3B	1 470	21.2
CRJ 100ER		3B	1 720	21.2	4.0
CRJ 200		3B	1 440	21.2	4.0
CRJ 200ER		3B	1 700	21.2	4.0
Dassault Aviation	Falcon 20	3B	1 463	16.3	3.7
	Falcon 200	3B	1 700	16.3	3.5
	F50/F50EX	3B	1 586	18.9	4.5
	Falcon 900	3B	1 504	19.3	4.6
	Falcon 900EX	3B	1 590	19.3	4.6
	F2000	3B	1 658	19.3	5.0
Embraer	EMB-135 LR	3B	1 745	20.0	4.1
Fokker	F28-1000	3B	1 646	23.6	5.8
	F28-2000	3B	1 646	23.6	5.8
I.A.I.	SPX	3B	1 644	16.6	—
	Galaxy	3B	1 798	17.7	—
Gulfstream Aero.	G IV-SP	3B	1 661	23.7	4.8
Nord	262	3B	1 260	21.9	3.4
Antonov	AN24	3C	1 600	29.2	8.8
Boeing	B717-200	3C	1 670	28.4	5.4
	B737-600	3C	1 690	34.3	7.0
	B737-700	3C	1 598	34.3	7.0
	Convair	240	3C	1 301	28.0

Aircraft Make	Model	Code	Aeroplane reference field length (m)	Wing span (m)	Outer main gear wheel span (m)
	440	3C	1 564	32.1	8.6
	580	3C	1 341	32.1	8.6
	600	3C	1 378	28.0	8.4
	640	3C	1 570	32.1	8.6
Douglas	DC3	3C	1 204	28.8	5.8
	DC4	3C	1 542	35.8	8.5
	DC6A/6B	3C	1 375	35.8	8.5
	DC9-20	3C	1 551	28.5	6.0
Embraer	EMB-120 ER	3C	1 481	19.8	6.6
Fokker	F27-500	3C	1 670	29.0	7.9
	F27-600	3C	1 670	29.0	7.9
	F28-3000	3C	1 640	25.1	5.8
	F28-4000	3C	1 640	25.1	5.8
	F28-6000	3C	1 400	25.1	5.8
	F50	3C	1 355	29.0	8.0
McDonnell Douglas	MD90	3C	1 798	32.9	6.2
SAAB	340A	3C	1 220	21.4	7.3
	340B	3C	1 220	22.8 ³	7.3
	SAAB 2000	3C	1 340	24.8	8.9
BAe	ATP	3D	1 540	30.6	9.3
DeHavilland Canada	DHC5D	3D	1 471	29.3	10.2
Airbus	A300 B2	3D	1 676	44.8	10.9
Bombardier Aero.	CRJ 100LR	4B	1 880	21.2	4.0
	CRJ 200LR	4B	1 850	21.2	4.0
Dassault Aviation	Falcon 20-5 (Retrofit)	4B	1 859	16.3	3.7
Embraer	EMB-145 LR	4B	2 269	20.0	4.1
Airbus	A320-200	4C	2 480	33.9	8.7
BAC	1-11-200	4C	1 884	27.0	5.2
	1-11-300	4C	2 484	27.0	5.2
	1-11-400	4C	2 420	27.0	5.2
	1-11-475	4C	2 286	28.5	5.4
	1-11-500	4C	2 408	28.5	5.2
Boeing	B727-100	4C	2 502	32.9	6.9
	B727-200	4C	3 176	32.9	6.9
	B737-100	4C	2 499	28.4	6.4
	B737-200	4C	2 295	28.4	6.4
	B737-300	4C	2 160	28.9	6.4
	B737-400	4C	2 550	28.9	6.4
	B737-500	4C	2 470	28.9	6.4
	B737-800	4C	2 090	34.3	7.0
	B737-900	4C	2 240	34.3	7.0
Fokker	F100	4C	1 840	28.1	6.0
Gulfstream Aero.	G V	4C	1 863	28.5	5.1
Douglas	DC9-10	4C	1 975	27.2	5.9
	DC9-15	4C	1 990	27.3	6.0
	DC9-20	4C	1 560	28.4	6.0

Aircraft Make	Model	Code	Aeroplane reference field length (m)	Wing span (m)	Outer main gear wheel span (m)
McDonnell Douglas	DC9-30	4C	2 134	28.5	5.9
	DC9-40	4C	2 091	28.5	5.9
	DC9-50	4C	2 451	28.5	5.9
	MD81	4C	2 290	32.9	6.2
	MD82	4C	2 280	32.9	6.2
	MD83	4C	2 470	32.9	6.2
	MD87	4C	2 260	32.9	6.2
	MD88	4C	2 470	32.9	6.2
Airbus	A300 B4	4D	2 605	44.8	10.9
	A300-600	4D	2 332	44.8	10.9
	A310	4D	1 845	44.8	10.9
Boeing	B707-300	4D	3 088	44.4	7.9
	B707-400	4D	3 277	44.4	7.9
	B720	4D	1 981	39.9	7.5
	B757-200	4D	1 980	38.1	8.6
	B757-300	4D	2 400	38.1	8.6
	B767-200	4D	1 981	47.6	10.8
	B767-300ER	4D	2 540	47.6	10.9
	B767-400ER	4D	3 130	51.9	10.8
	Canadair	CL44D-4	4D	2 240	43.4
Ilyushin	18V	4D	1 980	37.4	9.9
	62M	4D	3 280	43.2	8.0
Lockheed	L100-20	4D	1 829	40.8	4.9
	L100-30	4D	1 829	40.4	4.9
	L188	4D	2 066	30.2	10.5
	L1011-1	4D	2 426	47.3	12.8
	L1011-100/200	4D	2 469	47.3	12.8
	L1011-500	4D	2 844	47.3	12.8
Douglas	DC8-61	4D	3 048	43.4	7.5
	DC8-62	4D	3 100	45.2	7.6
	DC8-63	4D	3 179	45.2	7.6
	DC8-71	4D	2 770	43.4	7.5
	DC8-72	4D	2 980	45.2	7.6
	DC8-73	4D	3 050	45.2	7.6
McDonnell Douglas	DC10-10	4D	3 200	47.4	12.6
	DC10-30	4D	3 170	50.4	12.6
	DC10-40	4D	3 124	50.4	12.6
Tupolev	TU134A	4D	2 400	29.0	10.3
	TU154	4D	2 160	37.6	12.4
Boeing	B747-100	4E	3 060	59.6	12.4
	B747-200	4E	3 150	59.6	12.4
	B747-300	4E	3 292	59.6	12.4
	B747-400	4E	2 890	64.9 ⁴	12.6
	B747-SR	4E	1 860	59.6	12.4
	B747-SP	4E	2 710	59.6	12.4
	B777-200	4E	2 390	61.0	12.9
	B777-200ER	4E	3 110	61.0	12.9

Aircraft Make	Model	Code	Aeroplane reference field length (m)	Wing span (m)	Outer main gear wheel span (m)
McDonnell Douglas	B777-300	4E	3 140	60.9	12.9
	B777-300ER	4E	3 120	64.8	12.9
	MD11	4E	3 130	52.0 ⁴	12.6
Airbus	A380	4F	3 350	79.8	15

1. Over a 15 m obstacle.
 2. With wing tip tanks installed.
 3. With extended wing tips.
 4. Winglets.
-

Appendix 4

TAXIWAY DEVIATION STUDIES

Introduction

Note.— There have been several studies to measure aircraft deviations from taxiway centre lines. This appendix contains examples of studies conducted in London and Amsterdam. The results are specific or particular to each airport, pavement surfaces and weather conditions. While these studies may be of guidance to those intending to carry out similar studies, it may not be appropriate to use the results directly where any or some of the local factors are different from those used in these studies. Safety of operations must be the overriding concern whenever studies aimed at operating with separation distances less than the minimum safety clearances specified in Table 3-1 of Annex 14, Volume I are contemplated.

London/Heathrow study

1. A taxiway deviation study was carried out by British Airports Public Ltd. at London Heathrow Airport. Over 77 000 aircraft taxiing movements in all weather conditions were recorded. The purpose of the study was to show that pilots do not deviate significantly from the centre line when taxiing. The analysis of the data had two objectives. The primary objective was to estimate the probability of two Boeing 747-400 aircraft colliding wing tips when passing each other on parallel taxiways. The secondary objective was to estimate the expected number of years that would elapse before this collision occurred. The study also attempted to assess the adequacy of the separation distances between parallel taxiway runways and between taxiways and objects, as recommended in Annex 14, Table 3-1.

Straight sections of taxiways

2. Based on some 2 000 observations of B747 deviations on the straight sections of taxiways, the study concluded that the probability of two B747-400 aircraft colliding when passing each other on parallel taxiways is around 10^{-8} , i.e. 1 in 100 million. This assumes that the taxiway centre lines are 76.5 m apart and that the aircraft have

a wing span of 65 m. Upon analysing the data in the large data base which had been established, there was ample evidence to indicate that taxiing aircraft do not deviate from taxiway centre lines to any great degree. The data also provided an estimate of the number of occasions per year that two standard B747s pass each other on Heathrow's parallel taxiways. This would be about 80 occasions per year out of around 34 000 B747 air transport movements. This low figure occurred because, in the majority of cases, the aircraft would be moving in the same direction through the taxiway system. Departing aircraft use one runway and arriving aircraft use another; their paths rarely overlap. Figure A4-1 shows the distribution of deviations upon which the analysis is based.

Curved sections of taxiways

3. It was considered that the probability of collision on curved sections on taxiways is of the same order of magnitude as in straight sections, i.e. 10^{-8} . There were not enough observations of B747 deviations on the curved sections of taxiway to repeat the analysis detailed for straight sections. Data were collected at two locations. Data from the inner curve proved not to be useful because there was a large paved area to the inside of it which pilots tended to cut across. The number of observations on the outer curve was low because several months of maintenance work had closed that part of the taxiway. Figure A4-2 shows the distribution of the 185 B747 deviations observed on the outer curve. The negative numbers are deviations from the centre line towards the inside of the curve. This is in a different form to Figure A4-1 which shows only absolute deviations. Figure A4-2 shows that almost all aircraft main wheels cut across the corner. For a collision to occur at a curved part of the parallel taxiway, the outer aircraft must deviate to the inside and the inner aircraft must deviate to the outside. Figure A4-2 shows that the latter is very unlikely to happen. The overall distribution suggests that the collision probability would be similar to that of straight sections, i.e. 10^{-8} . Curved sections of taxiways were regarded as less of a problem than straight sections of taxiways since there will always be fewer curved elements

in a given taxiway layout. Thus, the chance that two aircraft pass on a curved section is much less than on a straight section.

Speed effect

4. The analysis showed that an aircraft's speed does not effect its lateral deviation.

Bad weather effect

5. No link could be established between bad weather and large taxiway deviations. During the data collection period, most weather conditions were encountered including snow fall, heavy rain, strong winds and visibility reduced to 1 000 m.

Statistics for all aircraft

6. Tables A4-1 and A4-2 show summary statistics for all aircraft on the straight and the outer curved sections of taxiways, respectively.

Amsterdam Schiphol study

7. A taxiway centre line deviation test was conducted at Amsterdam's Schiphol Airport from October 1988 to September 1991. Over 9 000 ICAO Category E aircraft (mostly B747) taxiing movements were recorded over the three-year span. Using infra-red beams, data were collected for a straight and a curved section of the taxiway. The taxiway width was 22.9 m. The curved section had a centre line radius of 55 m and a turn of 120 degrees. Centre line lighting was provided on both sections of taxiway.

8. The data were used by the Boeing Company to accomplish a statistical analysis of aircraft landing gear deviations. The purpose of the study was to estimate the extreme probabilities of gear deviations (those well outside the range of observed deviations), as well as to obtain estimates of the probability of wing tip contact between two aircraft on parallel taxiways.

9. A summary of statistics for the taxiway data is provided in Table A4-3. The data from the curved section indicates that pilots of large aircraft use a judgmental oversteer technique to insure that the main landing gear remains on the pavement.

Deviation probability estimates

10. The fact that data do not exist for gear deviations greater than 3.54 m on straight taxiways necessitates extrapolation for probabilities for greater deviations.

Wing tip contact probability

11. Using the extrapolated probabilities of extreme main gear deviations, the probabilities of wing tip-to-wing tip contact between two aircraft on parallel taxiways were calculated. These probabilities depend on the probability distribution of the sum of the two taxiway deviations, noting that two simultaneous deviations on parallel taxiways are statistically independent.

12. Table A4-4 summarizes estimates of required taxiway separations and estimated 90 per cent upper bounds for various wingspan probabilities.

Estimates of required taxiway separations

13. As an example, the mean estimate of taxiway separation required for a probability of a 10^{-9} wing tip contact between two aircraft with 73.2 m wingspans is 80.5 m.

Conditions affecting deviation

14. Some conditions that were recorded with the deviation were the year, month, day, time, taxi speed and direction. The variability of deviations was not affected by these factors. For example, the standard deviation on the straight section is 68.8 cm. The standard deviation is 67.1 cm after removing any systematic deviation due to taxi direction, season and time of day. Thus, the practical significance (in contrast to the statistical significance) of these effects may be minimal.

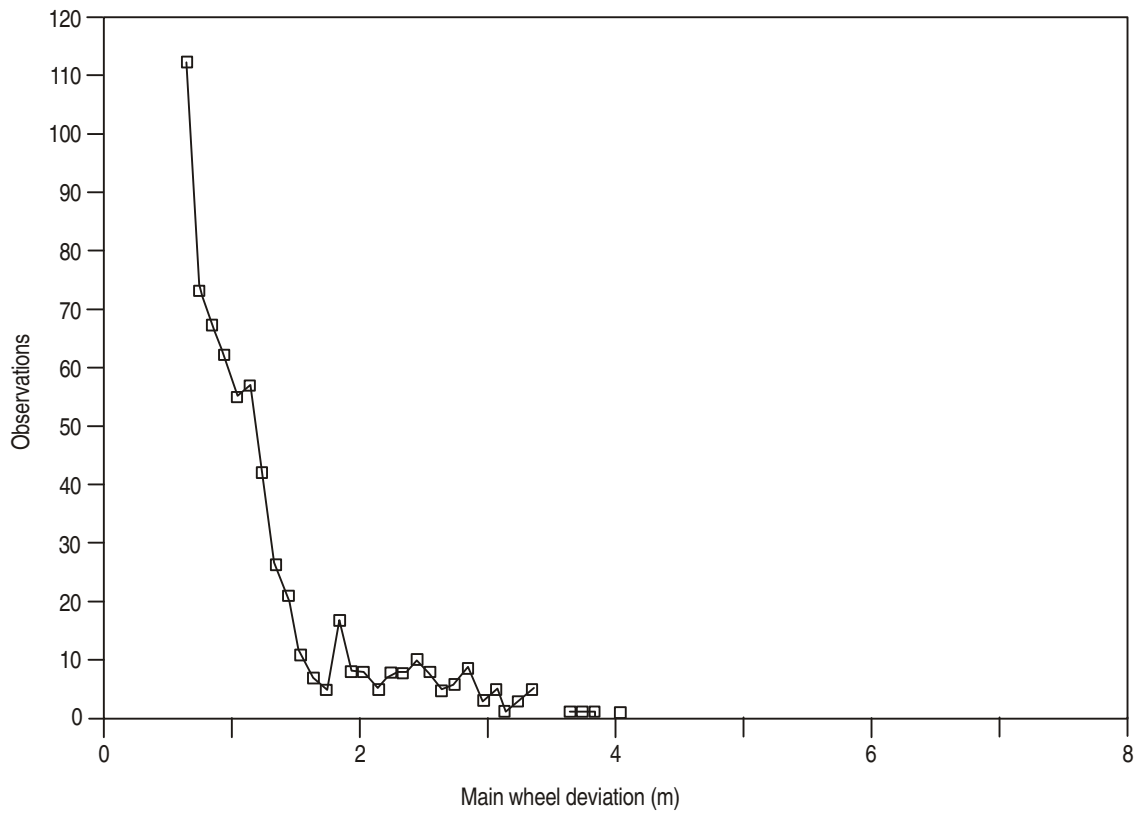

Figure A4-1. B747 main wheel deviations for straight sections of taxiway

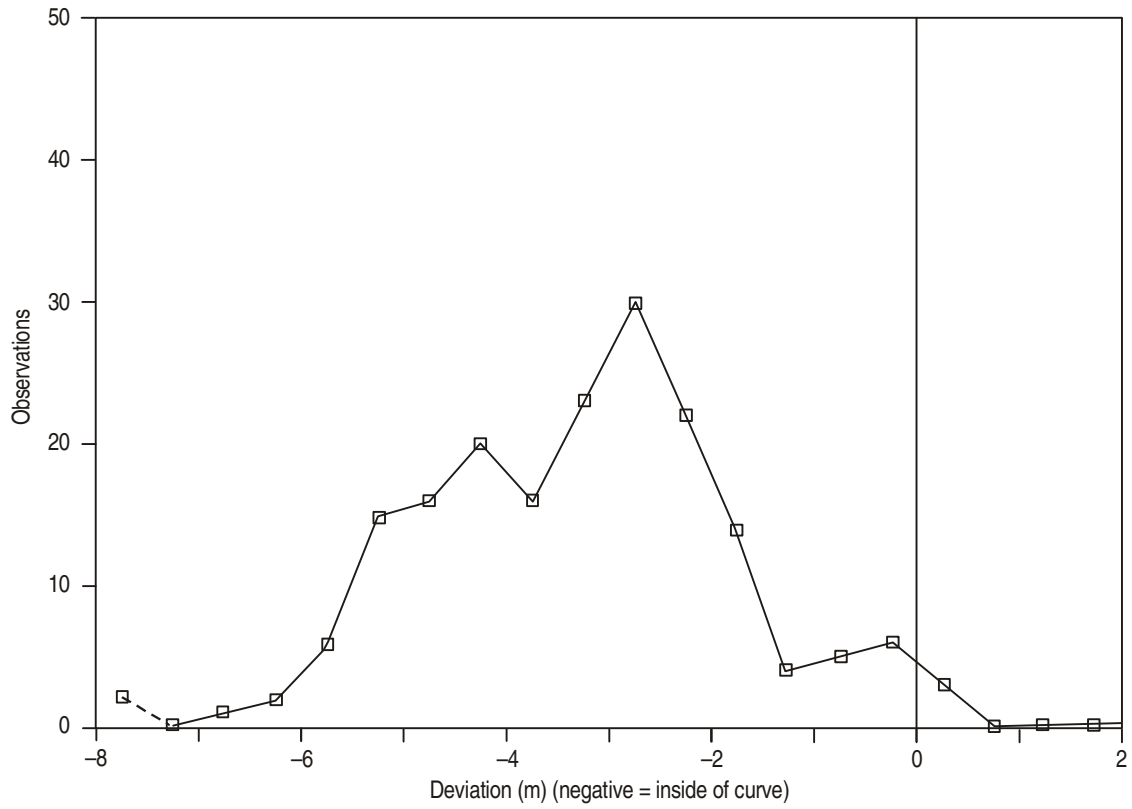

Figure A4-2. B747 main wheel deviations for curved sections of taxiway

Table A4-1. Summary statistics (straight sections of taxiway)

Aircraft	Main wheel deviation (m)			Nose wheel deviation (m)			Speed (kt)			Observations
	Mean	95%	Max	Mean	95%	Max	Mean	95%	Max	
A310	0.60	1.42	9.0	0.56	1.37	9.1	18.8	25	35	1 213
B727	0.65	1.85	8.1	0.56	1.36	9.0	18.9	27	49	1 997
B737	0.81	1.90	9.1	0.68	1.62	8.5	17.2	25	35	9 035
B747	0.59	1.90	4.1	0.47	1.21	7.8	17.3	25	34	1 988
B757	0.72	1.74	7.9	0.63	1.43	6.1	16.1	24	35	6 089
BAC1-11	0.65	1.53	9.5	0.63	1.49	8.2	15.8	23	33	3 749
DC9S	0.68	1.62	9.5	0.63	1.50	8.7	17.2	25	39	2 941
DC9	0.59	1.44	8.4	0.57	1.42	8.2	16.2	24	33	2 885
F27	0.95	2.39	9.6	0.62	1.47	9.6	17.9	26	32	1 075
F28	1.26	5.73	10.0	1.00	4.63	9.2	17.2	24	33	745
S360	0.80	2.00	7.4	0.63	1.43	9.2	17.1	23	27	1 528
L1011	0.50	1.22	8.9	0.46	1.13	5.2	17.1	25	31	722

Table A4-2. Summary statistics (outer taxiway curve)

Aircraft	Main wheel deviation (m)					Nose wheel deviation (m)					Speed (kt)			Observations
	Mean	Min	5%	95%	Max	Mean	Min	5%	95%	Max	Mean	95%	Max	
A310	-2.2	-6.4	-3.9	-0.5	+0.6	+0.54	-6.0	-1.3	+2.4	+4.6	16.0	21	27	848
B727	-1.92	-7.5	-3.7	+0.2	+2.5	+0.37	-5.2	-1.5	+2.2	+6.1	17.0	23	33	1 044
B737	-0.75	-5.0	-2.5	+0.9	+5.8	+0.32	-5.4	-1.4	+2.1	+5.4	16.6	22	30	3 152
B747	-3.31	-7.6	-5.7	-0.5	+0.1	-0.04	-4.1	-2.4	+2.6	+5.3	15.3	22	25	185
B757	-1.50	-7.7	-3.2	0.0	+2.5	+0.08	-3.7	-1.5	+2.0	+4.7	16.3	21	27	2 425
BAC1-11	-1.10	-9.7	-3.0	+0.7	+4.2	+0.47	-5.8	-1.4	+2.4	+6.1	16.4	22	27	962
DC9S	-1.09	-9.0	-3.2	+1.0	+3.6	-0.29	-8.3	-2.6	+1.9	+5.7	16.2	22	29	1 510
DC9	-1.11	-7.2	-3.0	-0.8	+2.0	+0.28	-3.0	-1.7	+2.3	+6.7	15.9	22	26	557
F27	-1.69	-7.4	-4.0	+0.4	+8.0	+0.39	-4.2	-1.4	+2.4	+9.2	17.1	23	27	465
F28	-1.33	-8.2	-3.8	+0.7	+9.2	+0.52	-8.9	-1.4	+2.5	+6.0	17.2	22	26	467
S360	-0.71	-9.6	-2.8	+1.1	+8.7	+0.47	-3.7	-1.3	+2.4	+4.2	17.0	22	25	534
L1011	-2.8	-5.9	-4.5	-0.8	+1.4	+0.18	-4.4	-2.2	+2.3	+3.4	14.5	20	26	255

Table A4-3. Summary of taxiway data

		ICAO Code E Aircraft		B747 (All Models)		Schiphol Report Code E Aircraft	
		Nose	Main	Nose	Main	Nose	Main
Straight Section	Sample size	7 958	7 958	7 855	7 855	8 191	8 191
	Mean (cm)	-14.8	-12.5	-15.2	-13.2	-8.0	-26.0
	Std. dev. (cm)	68.5	76.4	67.4	68.8	68.0	70.0
Curved section	Sample size	1 382	1 382	1 351	1 351	1 380	1 380
	Mean (cm) ¹	393.5	-202.2	400.3	-199.8	389	-199
	Std. dev. (cm)	244.1	236.8	237.6	236.0	227	216

1. Positive number indicates value outside of curved centre line. Negative number indicates value inside of curved centre line.

Table A4-4. Estimates of taxiway separations and 90 per cent upper bounds

Wingspan	Estimates				90% bounds			
	10e ⁻⁶	10e ⁻⁷	10e ⁻⁸	10e ⁻⁹	10e ⁻⁶	10e ⁻⁷	10e ⁻⁸	10e ⁻⁹
67	72.8	73.4	73.9	74.4	73.3	73.9	74.6	75.2
70	75.8	76.4	76.9	77.4	76.4	76.7	77.6	78.2
73	78.9	79.5	80.0	80.5	79.4	80.0	80.7	81.3
76	81.9	82.5	83.0	83.5	82.4	83.1	83.7	84.3
79	85.0	85.6	86.1	86.6	85.5	86.1	86.7	87.4
82	88.0	88.6	89.1	89.6	88.5	89.2	89.8	90.4
85	91.1	91.7	92.2	92.7	91.6	92.2	92.8	93.5

Appendix 5

DESIGN, LOCATION AND NUMBER OF RAPID EXIT TAXIWAYS

5.1 Process of determination of the optimal location of the turn-off point

- | | | | |
|---------|--|----------|---|
| Step 1. | <p>Specify for which operational conditions runway capacity should be enhanced. Depending on the intended purpose of the runway, specific conditions could consist of:</p> <ul style="list-style-type: none"> • peak period • special weather situation • particular group of aircraft • alternating landings and departures | Step 5. | <p>The calculations have to be repeated for different typical wind conditions using the following formula:</p> $V_{th,ground} = V_{th} - V_{wind}$ $V_{wind} = \text{Headwind component}$ <p>Insert $V_{th,ground}$ instead of V_{th} in the respective formulas.</p> |
| Step 2. | <p>Determine the representative fleetmix for the scenario the exit is intended to serve. Future types of aircraft should be taken into account. If only a particular group of aircraft is supposed to use the exit, take only these into consideration. Eliminate the types of aircraft with a share less than a certain percentage (e.g. 5 or 10 per cent).</p> | Step 6. | <p>These calculations lead to an optimal turn-off point (OTP) for each type of aircraft for different wind conditions.</p> |
| Step 3. | <p>Decide if the runway/taxiway separation is sufficient to permit the design of a standard rapid exit taxiway (RET).</p> <p>Standard RETs are designed according to Figures 1-13 and 1-14 in Chapter 1.</p> <p>If the runway and taxiway system does not permit construction of a standard RET, the construction of a spiral-shaped exit is recommended in order to achieve a higher turn-off speed as compared to a 90° exit. This option would in particular apply to non-instrument runways.</p> | Step 7. | <p>Since the position of the touchdown point as well as the transition and braking distance show a certain scatter, a stretch of 100 m before and 200 m after the OTP is designated as the “optimal turn-off segment” (OTS). This also acknowledges the fact that pilots can minimize runway occupancy time by adjusting their braking technique accordingly.</p> |
| Step 4. | <p>Calculate the distances for flare, transition and braking for each type of aircraft by using the three segment method. For the turn-off</p> | Step 8. | <p>Find the OTS with the highest percentage of aircraft being served (OTS_{max}), by adding the percentage of those aircraft types for which the OTP lies within a particular OTS. The probability of the differing wind conditions should also be considered.</p> |
| | | Step 9. | <p>Determine the turn-off point belonging to OTS_{max}. This is the optimal location for a rapid exit taxiway, according to the requirements of the selected scenario.</p> |
| | | Step 10. | <p>If there is more than one OTS showing clearly a higher percentage than others, it</p> |

may be necessary to consider the construction of two or more rapid exits.

Step 11. Compare the determined turn-off point with the turn-off points which are considered optimal relative to the existing configuration of the runway/taxiway system. Note that a distance between exits of approximately 450 m is recommended and should be observed.

5.2 Example for the use of the method described in Chapter 1, 1.3

The following example is provided to illustrate the use of the method described in Chapter 1, 1.3. The calculations are based on the following assumptions:

- Aerodrome Reference Code number 4
- In order to enhance runway capacity under specified conditions, a new exit should be located between 1 800 m and 2 500 m from threshold on a non-instrument runway with a length of 2 500 m. In the touch down area the runway slope is -0.75 per cent.
- The exit should be commissioned by 2005.
- The runway should provide its full capacity in strong headwind conditions (headwind > 15 kts). In this situation it is the only runway available for landing as well as for take-off at this airport, and it has to serve all types of aircraft.
- In light wind conditions the runway is used exclusively for landing by commuter aircraft; for take-off, however, it is used by all types of aircraft, subject to the performance capabilities of the aircraft.

Step 1. The specific operational scenario involves the peak traffic period in strong headwind conditions and alternating landing and take-off operations for all aircraft types.

Step 2. The fleetmix anticipated for the year 2005 till 2015 is displayed in Table A5-1. For the calculation of the optimal location of the exit, only types of aircraft with a share higher than 10 per cent are taken into account (marked with *).

Step 3. A parallel taxiway exists at a distance of 120 m (centre line to centre line). A 180°

turn is necessary for landing aircraft to reach the apron. The design of a standard rapid exit taxiway (Figure 1-7) is not possible. See 1.3.12 for an alternative design of the exit. The turn-off speed for this type of exit would be 24 kts according to Figure 1-16.

Step 4. As all the relevant types of aircraft are part of category C and D, the touchdown point is located at a common position. According to the three segment method it can be calculated for a runway slope of -0.75 per cent with no tailwind as:

Aircraft category C and D:	S ₁ =	450 m
+ Correction for slope (-0.75 per cent):		+ 150 m
	S ₁ =	600 m

The speed over threshold can be found for each type of aircraft in the aircraft operating manual of the airlines and it leads to the transition distance:

	[V _{th} in kts]	
A/C:	V _{th} :	S ₂ :
B737	128	590 m
A320	133	615 m
RJ	121	555 m

Based on a turn-off speed of 24 kts and a deceleration rate of 1.5m/s² the braking distance can be computed:

	[V in kts, a in m/s ²]	
A/C:	V _{th} :	S ₃ :
B737	128	1 016 m
A320	133	1 112 m
RJ	121	888 m

Step 5. As the decisive factor is a strong headwind, the calculations for S₂ and S₃ are repeated for headwinds of 15, 20 and 25 kts with

$$V_{th,ground} = V_{th} - V_{wind}$$

V_{wind} = 15 kts

A/C:	V _{th} :	V _{th,ground} :	S ₂ :	S ₃ :
B737	128	113	515	752 m
A320	133	118	540	836 m
RJ	121	106	480	642 m

$V_{\text{wind}} = 20$ kts

A/C:	V_{th} :	$V_{\text{th,ground}}$:	S_2 :	S_3 :
B737	128	108	490	673 m
A320	133	113	515	752 m
RJ	121	101	455	568 m

$V_{\text{wind}} = 25$ kts

A/C:	V_{th} :	$V_{\text{th,ground}}$:	S_2 :	S_3 :
B737	128	103	465	597 m
A320	133	108	490	673 m
RJ	121	96	430	499 m

Step 6. The sum of S_1 , S_2 and S_3 gives the OTP for each type of aircraft and each wind condition (values rounded to 10 m):

A/C:	$V_{\text{wind}} = 0$	$V_{\text{wind}} = 15$ kts	$V_{\text{wind}} = 20$ kts	$V_{\text{wind}} = 25$ kts
B737	2 210 m	1 870 m	1 760 m	1 660 m
A320	2 330 m	1 980 m	1 870 m	1 760 m
RJ	2 040 m	1 800 m	1 620 m	1 530 m

Step 7. The OTS can be determined for each turn-off point. It reaches from 100 m before the OTP to 200 m after. All types of aircraft being served within this segment are added. The maximum possible value for the four different wind conditions is 4×100 per cent = 400 per cent. Figure A5-1 shows the determination of the OTS for the A320 with 20 kts headwind.

Step 8. Table A5-2 shows that the highest percentage of aircraft can be served with an OTS_{max} from 1 660 to 1 960 m or 1 700 to 2 000 m from threshold. The probability of different wind conditions is not considered, as the exit is required only in strong wind conditions. In normal weather conditions the traffic volume for this runway is far below the maximum runway capacity even without additional exit.

Step 9. As shown in Table A5-2 and Figure A5-2, the optimal turn-off point for OTS_{max} is located at a position of 1 760 m or 1 800 m from threshold.

Step 10. In this scenario, there is no need to consider the location of a second exit as no other peak for a different aircraft mix has been identified.

Step 11. If the runway/taxiway system does not dictate a different position, it is suggested that the turn-off point be located at a distance of:

$$S = 1800 \text{ m from threshold.}$$

5.3 Example for the design of a non-standard rapid exit taxiway

Chapter 1, 1.3.19 and Figure 1-12 specify that the construction of a standard RET would normally require a distance between the centre lines of the runway and a parallel taxiway of at least

$$d = (150 + 75) \times \sin(31^\circ) + d_R = 116 + d_R \text{ (in metres)}$$

(where d_R is the additional distance required for turns onto the taxiway centre line).

An alternate method for the construction of a parallel taxiway spaced at 120 m, which would accommodate a higher turn-off speed, as compared to a right-angled exit taxiway, is described below and shown in Figure A5-3.

The exit was designed as follows:

- **Centre line:** The first part of the turn-off curve approximates the shape of a spiral, with an initial turn-off radius of 160 m changing to 100 m in the second part. When an angle of 60° between the taxiway centre line and the runway axis is reached, the radius changes to 40 m. The third part of the turn shows a constant radius of 40 m until the 180° turn is completed.
- **Turn-off speed:** According to Chapter 1, Table 1-12, the turn-off speed is 24 kts for a radius of 160 m. The turn-off speed for a 40 m radius is 13 kts. The distance required for the aircraft to decelerate from 24 to 13 kts is approximately 140 m. This leads to a deceleration rate of $a = 0.4 \text{ m/s}^2$ along the turn-off curve, which is a safe value for all types of aircraft.
- **Inside fillet curve:** The inside fillet curve was designed to allow access to all types of aircraft using this airport. The critical aircraft is the B777-300 which at the present time has the longest datum length.

- **Outer edge:** In order to allow intersection take-offs from this exit, the outer edge is designed with a simple right angle. The distance from the centre line to the outer edge is 20 m at the closest point, providing adequate safety for all turning manoeuvres.

5.4 Calculation of the turn-off curve

The coordinates of the basic points of the turn-off curve were determined as shown in Figure A5-4 and in the following calculations (all values in metres).

With

$$R_1 = 160 \text{ m}$$

$$R_2 = 100 \text{ m}$$

$$R_3 = 40 \text{ m}$$

the calculations are valid for

$$112 \text{ m} \leq S \leq 127 \text{ m}$$

where S is the distance from centre line RWY to centre line TWY.

$$P_0: \quad \begin{aligned} x_0 &= 0 \\ y_0 &= 0 \end{aligned}$$

$$M_1: \quad \begin{aligned} x_{M1} &= 0 \\ y_{M1} &= R_1 \end{aligned}$$

$$P_1: \quad x_1 = R_1 \times \sin(\varphi_1)$$

$$\varphi_1 = 90^\circ - \arctan\left(\frac{a}{\sqrt{R_2^2 - a^2}}\right)$$

$$a = \frac{R_2 \times b}{R_1 - R_2}$$

$$b = R_1 + 10 - S$$

$$y_1 = R_1 - (a + b)$$

$$M_2: \quad x_{M2} = b \times \tan(\varphi_1)$$

$$y_{M2} = S - 10$$

$$P_2: \quad x_2 = b \times \tan(\varphi_1) + R_2 \times \frac{\sqrt{3}}{2}$$

$$y_2 = S - 60$$

$$\varphi_2 = 60^\circ$$

$$M_3: \quad x_{M3} = b \times \tan(\varphi_1) + (R_2 - 40) \times \frac{\sqrt{3}}{2}$$

$$y_{M3} = S - 40$$

$$P_3: \quad x_3 = x_{M3}$$

$$y_3 = S$$

Table A5-1. Anticipated fleetmix, 2005-2015

Aircraft:	Share:
B747	1.2%
B777	1.2%
A340	6.7%
A3xx	0.2%
B757	1.4%
B767	1.7%
B737*	22.3%
A330	6.4%
A320*	35.9%
RJ*	18.1%
Misc.	4.9%
Total	100.0%

Table A5-2.

Turn-off point [m]:	Turn-off segment [m]:	A/C served at V _{wind} [kts]:			Sum of share [%]:
		B737	A320	RJ	
1 530	1 430 – 1 730	25		20, 25	59
1 620	1 520 – 1 820	20, 25	25	15, 20, 25	135
1 660	1 560 – 1 860	20, 25	25	15, 20	117
1 760	1 660 – 1 960	15, 20, 25	20, 25	15	157
1 800	1 700 – 2 000	15, 20	15, 20, 25	15	170
1 870	1 770 – 2 070	15	15, 20	0, 15	130
1 980	1 880 – 2 180		15	0	54
2 040	1 940 – 2 240	0	15	0	76
2 210	2 110 – 2 410	0	0		58
2 330	2 230 – 2 530		0		36

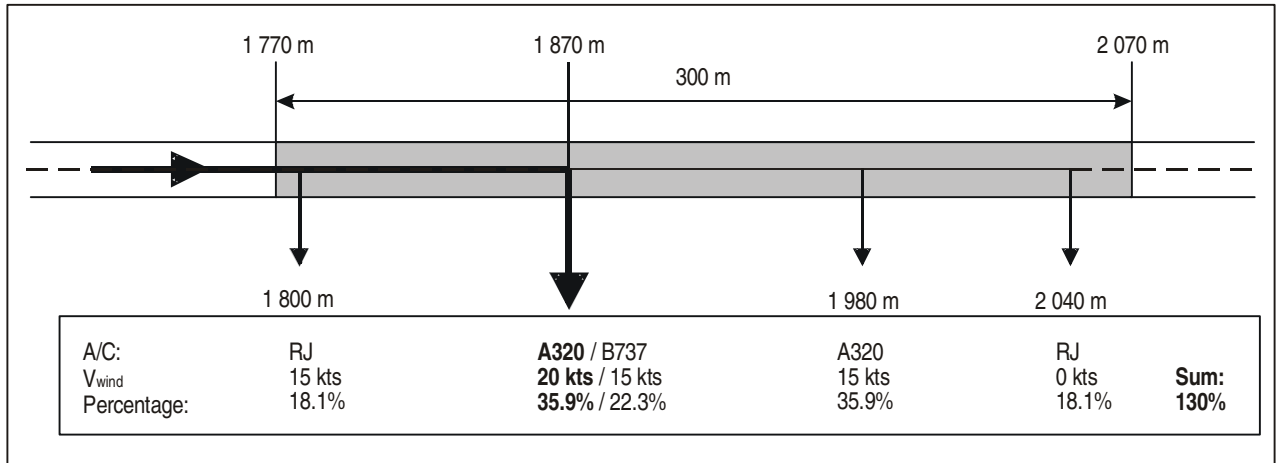

Figure A5-1. Optimal turn-off segment — A320

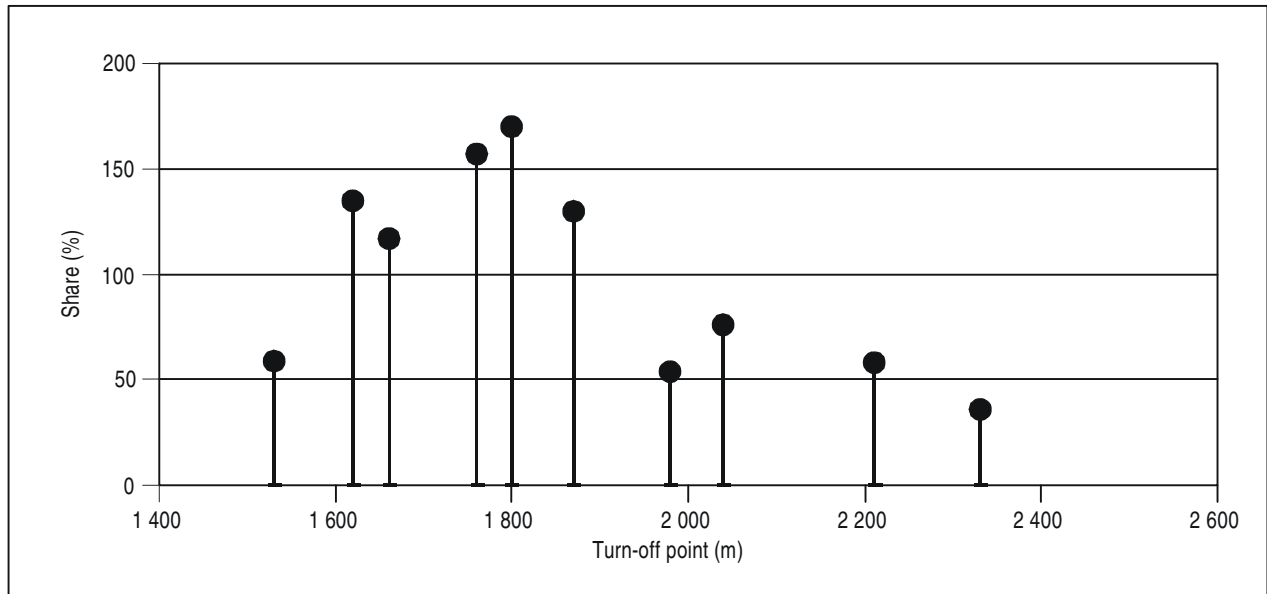

Figure A5-2. Optimal turn-off point

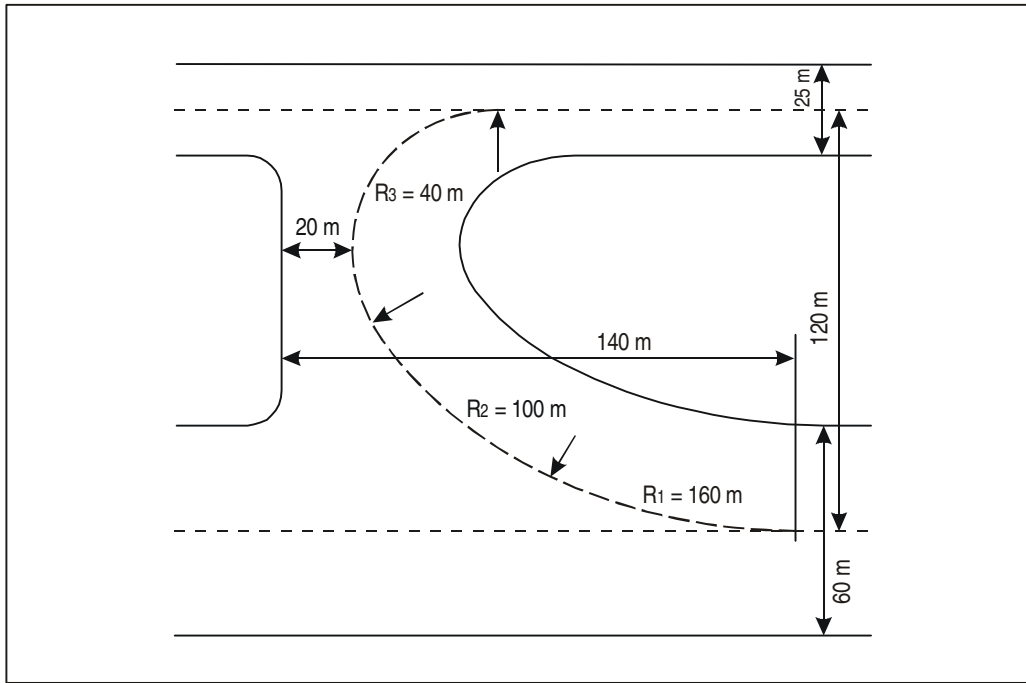

Figure A5-3. An alternative exit taxiway design

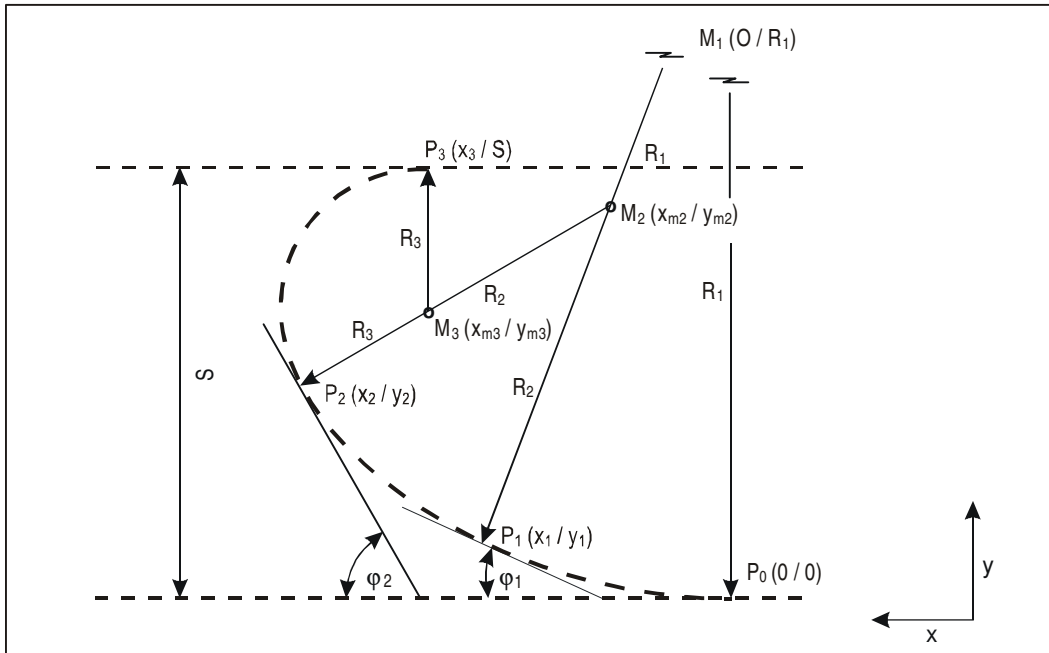

Figure A5-4. Calculation of the turn-off curve

— END —

© ICAO 2005
02/05, E/P1/1375; 02/07, E/P2/400;
02/08, E/P3/250

Order No. 9157P2
Printed in ICAO

