

TAKEOFF SAFETY TRAINING AID



U.S. Department
of Transportation
**Federal Aviation
Administration**

(This page intentionally left blank)

TAKEOFF SAFETY TRAINING AID

IMPORTANT - READ

**IF YOU DESIRE REVISION
SERVICE, PLEASE FILL IN THE
INFORMATION BELOW:**

COMPLETE ADDRESS (PLEASE TYPE OR PRINT)

COMPANY _____
NAME _____
TITLE _____
ADDRESS _____

RETURN TO:

**BOEING COMMERCIAL AIRPLANE GROUP
P.O. BOX 3707
SEATTLE, WASHINGTON 98124-2207 USA**

**ATTN: MANAGER, AIRLINE SUPPORT
CUSTOMER TRAINING AND FLIGHT
OPERATIONS SUPPORT
ORG. M-7661
MAIL STOP 2T-65**

(This page intentionally left blank)



U.S. Department
of Transportation

**Federal Aviation
Administration**

Office of the Administrator

800 Independence Ave., S.W.
Washington, D.C. 20591

AUG 13 1992

Captain Chester L. Ekstrand
Director, Flight Training
Boeing Commercial Airplane Group
P.O. Box 3707, MS 2T-62
Seattle, WA 98124-2207

Dear Captain Ekstrand:

It is a pleasure to recommend this "Takeoff Safety Training Aid" for use throughout the air carrier industry. This training tool is the culmination of a long, painstaking effort on the part of an industry/Government working group representing a broad segment of the U.S. and international air carrier community.

In late 1990, the working group began studying specific cases of rejected takeoff (RTO) accidents and incidents and related human factors issues. Opportunities for making improvements to takeoff procedures and for increasing the levels of aircrew knowledge and skill were indicated. To test this hypothesis, the working group was expanded to include all major aircraft manufacturers, international carriers, and members of the academic community. The general consensus supports enhancing flight safety through widespread use of the material developed.

I urge operators to adopt this material for use in qualification and recurring aircrew training programs. I am convinced that adopting these materials will make genuine improvements in safety for one of the most critical phases of flight.

My thanks to the members of the working group. Again, the industry/Government partnership for safety is working well for the protection of the flying public.

Sincerely,

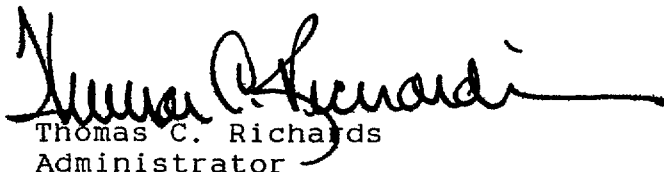
Thomas C. Richards
Administrator

(This page intentionally left blank)



U.S. Department
of Transportation

Federal Aviation
Administration

Advisory Circular

Subject: TAKEOFF SAFETY TRAINING AID Date 9/12/194 AC No: 120-62
Announcement of Availability Initiated by: AFS-210 Change:

1. **PURPOSE.** This advisory circular (AC) announces the availability of a joint industry/Federal Aviation Administration (FAA) Takeoff Safety Training Aid to help air carriers and pilots increase safety during the takeoff phase of flight.

a. The FAA recommends early consideration of the information contained in the aid and use of the material, as appropriate, for training aircrews. This AC also highlights certain key items, concepts, and definitions that each air carrier or operator should address in their respective operational procedures and crew qualification programs.

b. This circular applies to Federal Aviation Regulations (FAR) Part 121 operators. However, many of the principles, concepts, and procedures described apply to operations under FAR Parts 91, 129, and 135 for certain aircraft, and are recommended for use by those operators when applicable.

2. **BACKGROUND.** Takeoff accidents resulting from improper rejected takeoff (RTO) decisions and procedures are significant contributors to worldwide commercial aviation accident statistics. For those takeoffs that are rejected, and for takeoffs made under certain environmental conditions with certain system failures, risks could be reduced by a higher level of flightcrew knowledge and by the use of improved procedures. Due to the risks and accident statistics associated with takeoffs, a joint FAA/industry team studied what actions might be taken to increase takeoff safety. These studies included simulation trials and in-depth analysis of takeoff accidents and incidents. To present the findings of this group, a comprehensive training aid for operators and pilots of transport aircraft was prepared.

a. The goal of the Takeoff Safety Training Aid is to minimize, to the greatest extent practical, the probability of RTO-related accidents and incidents by:

(1) improving the ability of pilots to take advantage of opportunities to maximize takeoff performance margins;

(2) improving the ability of pilots to make appropriate Go/No Go decisions; and

(3) improving the ability of crews to effectively accomplish RTO related procedures. The training aid consists of four sections. These sections are listed below:

(i) Takeoff Safety-Overview for Management: This section includes an introduction, objectives, and an overview of the training aid;

(ii) Pilot Guide to Takeoff Safety: This section summarizes key RTO information for flightcrews. It includes an analysis of past RTO overrun accidents, and a discussion of information pilots should know in order to make better “Go/No Go” decisions. This section is intended for personal reading by all jet transport airplane pilots;

(iii) Example Takeoff Safety Training Program: This section provides ground and simulator training modules with a guide for implementing the simulator training; and

(iv) Takeoff Safety-Background Data: This section is an expansion of the Pilot Guide with selected and related supporting data provided by Appendix. This section targets instructors and training program developers.

b. This AC announces the general availability of the Takeoff Safety Training Aid. Additional related materials that support this aid (vides, model specific performance data, pictures, briefing materials, etc.) may be available from the manufacturers. This circular endorses the industry-developed training aid and the associated materials developed by each manufacturer in support of reducing the number of RTO overrun accidents and incidents.

3. HOW TO OBTAIN COPIES. For a fee, the Takeoff Safety Training Aid may be obtained by the general public from the National Technical Information Service (NTIS), 5285 Part Royal Road, Springfield, Virginia 22161, (703) 487-4650. The NTIS reference number for the Takeoff Safety Training Aid is PB93780013.

a. Some aircraft manufacturers have developed supporting instructional materials which may be available through their customer service and training departments.

b. Specific aircraft performance data relating to rejected takeoffs has been developed by Airbus Industries, Boeing, and McDonnell Douglas. These data packages are helpful in modeling certain scenarios through simulation for specific aircraft.

Airbus Industries:

Capt A. Guillard, VP Training
Aeroformation
Avenue Pierre, La Techoere St.
31700 Bloagnach
FRANCE

Phone: 33 61 932080

Boeing:

Boeing Commercial Aix-plane Group ATTN: Manager, Airline Support
Customer Training and Flight Operations Support MIS 2T-65
P.O. Box 3707
Seattle, WA 98124

Phone: (206) 544-5421

Mc Donnell Douglas:

Douglas Aircraft Co. MC 94-25
3855 Lakewood Blvd.
Long Beach, CA 90846
ATTN: Dr. Diane Schapiro
General Manager Flight Operations Safety and Training

Phone: (310) 496-8582

4. RELATED FEDERAL AVIATION REGULATIONS (FAR) SECTIONS.

- a. Part 121, Subpart E - Approval of Routes: Domestic and Flag Air Carriers. Section 121.97.
- b. Part 121, Subpart F - Approval of Areas and Routes for Supplemental Air Carriers and Commercial Operators. Section 121.117
- c. Part 121, Subpart G - Manual Requirements. Section 121.135.
- d. Part 121, Subpart I - Airplane Performance Operating Limitations. Sections 121.171, 121.173, and 121.189.
- e. Part 121, Subpart K - Instrument and Equipment Requirements. Section 121.315.
- f. Part 121, Subpart N - Training Program. Sections 121.401, 121.403 121, 121.405, 121.407, 121.409, 121.411, 121.413, 121.415, 121.418: 121.419, 121.422, 121.424-425, 121.427, and 121.439.
- g. Part 121, Subpart O - Crewmember Qualifications. Sections 121.433, 121.441, 121.443, and 121.445.
- h. Part 121, Appendices E, F, and H.

5. RELATED READING MATERIAL

- a. AC 91-6A, Water, Slush, and Snow on the Runway
- b. AC 120-40B, Airplane Simulator Qualification.
- c. AC 120-51A, Crew Resource Management.

6. DEFINITIONS. Certain definitions are needed to explain the concepts discussed in this training aid. Some of the definitions used are taken from the FAR's or other references, and some are defined in the training aid. Where appropriate, the training aid definitions have been written from the point of view of the pilot and may clarify or expand on the regulatory definition to the extent necessary to assure appropriate flightcrew action.

a. V₁. The speed selected for each takeoff, based upon approved performance data and specified conditions, which represents:

(1) The maximum speed by which a rejected takeoff must be initiated to assure that a safe stop can be completed within the remaining runway, or runway and stopway;

(2) The minimum speed which assures that a takeoff can be safely completed within the remaining runway, or runway and clearway, after failure of the most critical engine at the designated speed; and

(3) The single speed which permits a successful stop or continued takeoff when operating at the minimum allowable field length for a particular weight.

Note 1: Safe completion of the takeoff includes both attainment of the designated screen height at the end of the runway or clearway, and safe obstacle clearance along the designated takeoff flight path.

Note 2: Reference performance conditions for determining V_1 may not necessarily account for all variables possible affecting a takeoff, such as runway surface friction, failures other than a critical powerplant etc.

b. Minimum V_1 . The minimum permissible V_1 speed for the reference conditions from which the takeoff can be safely completed from a given runway, or runway and clearway, after the critical engine had failed at the designated speed.

c. Maximum V_1 . That maximum possible V_1 speed for the reference conditions at which a rejected takeoff can be initiated and the airplane stopped within the remaining runway, or runway and stopway.

d. Reduced V_1 . A V_1 less than maximum V_1 or the normal V_1 , but more than the minimum V_1 , selected to reduce the RTO stopping distance required.

Note: V_1 speeds based on wet or slippery conditions are reduced V_1 's to adjust the RTO stopping distance for the degraded stopping capability associated with the conditions. Reducing V_1 for a dry runway takeoff, when conditions permit, will provide additional stopping margin in the event of an RTO. In either case, the reduced V_1 must be determined to also assure the continued takeoff criteria are met (i.e., screen height, obstacle clearance, and V_{MCG}).

e. V_R . Rotation speed.

f. V_{LOF} . Lift-off speed.

g. V_2 . Minimum takeoff safety speed.

h. Screen Height. The height of an imaginary screen which the airplane would just clear at the end of the runway, or runway and clearway, in an unbanked attitude with the landing gear extended.

i. Takeoff Distance. The horizontal distance from the start of the takeoff to the point where the airplane reaches the prescribed screen height above the surface with a critical engine having failed at the designated speed or, 115% of the horizontal distance from the start of takeoff to the point where the airplane reaches the prescribed screen height above the surface with all engines operating.

j. Accelerate-Go Distance. The horizontal distance from the start of the takeoff to the point where the airplane reaches the prescribed screen height above the takeoff surface with the critical engine having failed at the designated speed.

k. Accelerate-Stop Distance. The horizontal distance from the start of the takeoff to the point where the airplane is stopped in the runway or runway and stopway, when the stop is initiated at V_1 and completed using the approved procedures and specified conditions.

l. Balanced Field Length. The runway length (or runway plus clearway and/or stopway) where, for the takeoff weight, the engine-out accelerate-go distance equals the accelerate-stop distance.

m. Critical Field Length. The minimum runway length (or runway plus clearway and/or stopway) required for a specific takeoff weight. This distance may be the longer of the balanced field length, 115% of the all engine takeoff distance, or established by other limitations such as maintaining V_1 to be less than or equal to V_R .

n. Derated Takeoff Thrust. A takeoff thrust level less than the maximum takeoff thrust approved for an airplane/engine for which a separate and specific set of data which complies with all of the requirements of FAR Part 25 exists. When operating with a derated takeoff thrust, the thrust setting parameter used to establish thrust for takeoff is presented in the AFM and is considered an operating limit for that takeoff.

o. Reduced Takeoff Thrust. A takeoff thrust level less than the maximum (or derated) takeoff thrust. The takeoff performance and thrust settings are established by approved simple methods, such as adjustments or corrections to the takeoff performance and thrust settings defined for the maximum thrust (or derated) performance and thrust settings. When operating with a reduced takeoff thrust, the thrust setting parameter used to establish thrust for takeoff is not considered an operating limit; the

p. Clearway. A cleared area beyond the end of the runway, not less than 500 feet wide, centrally located about the extended center line of the runway, that contains no obstructions and is under the control of the airport authorities.

q. Stopway. An area beyond the end of the runway, at least as wide as the runway and centered along the extended center line of the runway, able to support the airplane during a rejected takeoff without causing structural damage to the airplane, and designated by the authorities for use in decelerating the airplane during a rejected takeoff.

r. Rejected Takeoff. A takeoff that is discontinued after takeoff thrust is set and initiation of the takeoff roll has begun.

7. USE OF THE TAKEOFF SAFETY TRAINING AID. Operators should use this training aid in development or modification of their various training and crew qualification programs. This information may be helpful for other applications or assessments related to takeoff safety as shown in item (b) below.

a. Maintaining or Improving Airman Knowledge and Skills. Training aid information should be used for:

(1) Training program preparation or revisions, including upgrade, initial, transition, difference, recurrent, or requalification programs;

(2) Incorporation in Advanced Qualification Program curriculum segments;

(3) Incorporation in crew resource management or line oriented flight training;

(4) Briefing of check airmen to address pertinent items during various checks and evaluations, including annual proficiency check/proficiency training events, operational experience, line checks, and route checks;

(5) Incorporation of takeoff scenarios in airman training, certification, recurrency, and proficiency evaluation activities;

(6) Training of other airmen such as dispatchers; and

(7) Preparation of crew bulletins or manual materials.

b. Other Applications. Training aid information may be used:

(1) To assist in reviewing an operator's V speed and "call out" policies, and incorporating the latest validated procedures such as use of the "reduced V_1 " concept;

(2) To assist in reviewing RTO and continued takeoff procedures to ensure that the latest validated information is being provided to flightcrews;

(3) To assist in reviewing dispatch policies to ensure the latest validated information, procedures, and policies are being;

(4) To assist in reviewing an operator's performance engineering methods and programs to ensure that the latest validated information, procedures, and policies are being used (e.g., clutter correction methods and appropriate line up distance assumptions);

(5) To assist in reviewing an operator's maintenance practices to ensure that the latest validated information, procedures, and policies are being used (brake wear policies, minimum equipment list use, etc.);

(6) To assist in reviewing various operator manuals to ensure that the latest validated information, procedures, and policies are being used;

(7) To assist in planning for the most desirable safety options to be selected when making decisions about acquisition of new aircraft or modification of existing aircraft (availability or capability of auto brake-systems, reverse thrust, anti skid, auto spoilers, flight manual data appendices, etc.);

(8) To assist in planning for the purchase, lease, or modification of simulators and training devices to provide the most desirable options (appropriate simulator response for RTO'S, realistic visual representation of critical scenarios, incorporation of relevant systems such as auto brakes, etc.); and

(9) To assist in formulation of airline special emphasis or seasonal programs.

8. TRAINING AID KEY PROVISIONS. The following key elements of takeoff safety training aid are recommended, as a minimum, for implementation by each air carrier.

a. Ground Training. The ground training program should ensure thorough crew awareness in at least the following topics:

(1) Proper RTO and takeoff continuation procedures in the event of failures;

(2) Potential effects of improper procedures during an RTO;

(3) Guidelines on rejecting or not rejecting a takeoff in the low and high speed regimes;

(4) Assigned crewmember duties, use of comprehensive briefings, and proper crew coordination;

(5) Appropriate selection of runway, flap settings, thrust levels, and V speeds relative to takeoff conditions (gross weight, runway contaminants, etc.);

(6) Proper use of "reduced VI" policies if used; and

(7) The increased stopping distance required on slippery or contaminated runways.

b. Flight Training and Checking. Flight Training programs and airmen evaluations, to the extent appropriate, using an approved simulator should ensure appropriate crew skill in applying the items listed in (a) above. Simulator scenarios should include the following conditions and procedures:

(1) The use of critical weights for a specified runway (e.g., critical field length/balanced field length).

(2) Demonstration of the increased stopping distance required on slippery or contaminated runways.

(3) Demonstration of the proper and appropriate crew responses for engine failure, tire failure, nuisance alerts, and critical failures that effect the ability to safely continue the takeoff in both the high and low speed regimes.

c. Crew Resource Management (CRM). The topics of ground training and scenarios suggested for flight training and checking, as shown above, including specific behaviors associated with decision making, crew coordination/communication, and team building. Therefore, those carriers who have CRM training separate from ground or flight training should include the appropriate topics and scenarios in their CRM program.

9. ASSESSMENT OF SIMULATORS AND TRAINING DEVICES. Any simulators or training devices used to support programs related to the Takeoff Safety Training Aid should be assessed using the guidelines of section 3.3 of the aid to ensure appropriate characteristics. Planning for new, leased, or modified simulators or training devices should also consider those guidelines to ensure that future devices will have the necessary capability to satisfy takeoff safety training objectives.

10. OTHER FACTORS AFFECTING TAKEOFF SAFETY. Other factors affecting takeoff safety such as deicing precautions, winter operations, windshear, engine-out takeoff obstacle clearance criteria, and other topics are addressed by other references and are not repeated in the takeoff safety training aid. To ensure a comprehensive air carrier program, other references listed in paragraph 4 of this AC should be consulted.

William J. White
Deputy Director, Flight Standards Service

(This page intentionally left blank)

Takeoff Safety Training Aid

REVISION HIGHLIGHTS

Revision 1 to the *Takeoff Safety Training Aid* dated April 2, 1993

The following changes comprise this revision:

<u>PAGE</u>	<u>CODE</u>	<u>EXPLANATION</u>
<u>Log of Pages</u> 1,2,3,4,5	R1	Added Log of Pages to document.
<u>Section 2</u> 2.i	R1	Typographical correction.
2.26	R1	Correction of statement on tire failures.
<u>Section</u> 4.35	R1	Completed the last sentence in the right hand column.

(This page intentionally left blank)

Takeoff Safety Training Aid

Log of Pages to the, Takeoff Safety Training Aid

<u>PAGE</u>	<u>CO</u>	<u>DE</u>	<u>DATE</u>
Draft Advisory Circular			
		AC120-XX	08-03-92
Title			
1			
Log of Pages			
* 1		R1	04-02-93
* 2		R1	04-02-93
* 3		R1	04-02-93
* 4		R1	04-02-93
* 5		R1	04-02-93
Table of Contents			
i			
ii			
Section 1			
1.i			
1.ii			
1.1			
1.2			
1.3			
1.4			
Section 2			
* 2.1			
2.ii			
2.1			
2.2		R1	04-02-93
2.3			
2.4			
2.5			
2.6			
2.7			
2.8			
2.9			
2.10			
2.11			
2.12			

<u>PAGE</u>	<u>CO</u>	<u>DE</u>	<u>DATE</u>
Section 2 (coat)			
2.13			
2.14			
2.15			
2.16			
2.17			
2.18			
2.19			
2.20			
2.21			
2.22			
2.23			
2.24			
2.25			
* 2.26	R1		04-02-93
2.27			
2.28			
2.29			
2.30			
2.31			
2.32			
2.33			
2.34			
2.35			
2.36			
2.37			
2.38			
2.39			
2.40			
2.41			
2.42			
Section 3			
3.i			
3.ii			
3.1			
3.2			
3.3			
3.4			
3.5			
3.6			
3.7			
3.8			
3.9			
3.10			
3.11			
3.12			

CODE: Original issue unless otherwise noted by R# = Revision number and date.[]

* Revised Pages[]

4/9/93[]

Page 1 of 5[]

R1

<u>PAGE</u>	<u>CO</u>	<u>DE</u>	<u>DATE</u>
Section 3 (cont)			
3.13			
3.14			
3.15			
3.16			
3.17			
3.18			
Appendix 3-A			
App.3-A.1			
App.3-A.2			
App.3-A.3			
App.3-A.4			
App.3-A.5			
App.3-A.6			
Appendix 3-B			
App.3-B.i			
App.3-B.ii			
App.3-B.1			
App.3-B.2			
App.3-B.3			
App.3-B.4			
App.3-B.5			
App.3-B.6			
App.3-B.7			
App.3-B.8			
App.3-B.9			
App.3-B.10			
App.3-B.11			
App.3-B.12			
App.3-B.13			
App.3-B.14			
App.3-B.15			
App.3-B.16			
App.3-B.17			
App.3-B.18			
Appendix 3-C			
App.3-C.i			
App.3-C.ii			
Title			
Page 1			
Figure 1			
Page 2			
Figure 2			
Page 3			

<u>PAGE</u>	<u>CO</u>	<u>DE</u>	<u>DATE</u>
Appendix 3-C (cont)			
Figure 3			
Page 4			
Figure 4			
Page 5			
Figure 5			
Page 6			
Figure 6			
Page 7			
Figure 7			
Page 8			
Figure 8			
Page 9			
Figure 9			
Page 10			
Figure 10			
Page 1 I			
Figure 11			
Page 12			
Figure 12			
Page 13			
Figure 13			
Page 14			
Figure 14			
Page 15			
Figure 15			
Page 16			
Figure 16			
Page 17			
Figure 17			
Page 18			
Figure 18			
Page 19			
Figure 19			
Page 20			
Figure 20			
Page 21			
Figure 21			
Page 22			
Figure 22			
Page 23			
Figure 23			
Page 24			
Figure 24			
Page 25			
Figure 25			
Page 26			

CODE: Original issue unless otherwise noted by R# = Revision number and date.[]

<u>PAGE</u>	<u>CO</u>	<u>DE</u>	<u>DATE</u>
Appendix 3-C (cont)			
Figure 26			
Page 27			
Figure 27			
Page 28			
Figure 28			
Page 29			
Figure 29			
Page 30			
Figure 30			
Page 31			
Figure 31			
Page 32			
Figure 32			
Page 33			
Figure 33			
Page 34			
Figure 34			
Page 35			
Figure 35			
Page 36			
Figure 36			
Page 37			
Figure 37			
Page 38			
Figure 38			
Page 39			
Figure 39			
Page 40			
Figure 40			
Page 41			
Figure 41			
Page 42			
Figure 42			
Page 43			
Figure 43			
Page 44			
Figure 44			
Page 45			
Figure 45			
Page 46			
Figure 46			
Page 47			
Figure 47			
Page 48			
Figure 48			
Page 49			

<u>PAGE</u>	<u>CO</u>	<u>DE</u>	<u>DATE</u>
Appendix 3-C (cont)			
Figure 49			
Page 50			
Appendix 3-D App.3-D.i			
App.3-D.ii			
(Other pages supplied by specific manufacturers)**			
Section 4			
4.i			
4.ii			
4.1			
4.2			
4.3			
4.4			
4.5			
4.6			
4.7			
4.8			
4.9			
4.10			
4.11			
4.12			
4.13			
4.14			
4.15			
4.16			
4.17			
4.18			
4.19			
4.20			
4.21			
4.22			
4.23			
4.24			
4.25			
4.26			
4.27			
4.28			
4.29			
4.30			
4.31			
4.32			
4.33			
4.34			

CODE: Original issue unless otherwise noted by R# = Revision number and date.[]

**Boeing and Douglas Model-Specific data are incorporated into this report.

*Revised Pages[]

4/9/93[]

Page 3 of 5[]

R1

<u>PAGE</u>	<u>CO</u>	<u>DE</u>	<u>DATE</u>
* 4.35		R1	04- 02-93
4.36			
4.37			
4.38			
4.39			
4.40			
4.41			
4.42			
4.43			
4.44			
4.45			
4.46			
4.47			
4.48			
4.49			
4.50			
4.51			
4.52			
4.53			
4.54			
Appendix 4-A			
App. 4-A.i			
App. 4-A.ii			
Complete NTSB Report (SIR-90/02) with appendices			
Appendix 4-B			
App. 4-B.i			
App. 4-B.ii			
App. 4-B.1			
App. 4-B.2			
Appendix 4-C			
App.4-A.i			
App.4-A.ii			
App.4-A.1			
App.4-A.2			
App.4-A.3			
App.4-A.4			
App.4-A.5			
App.4-A.6			
App.4-A.7			
App.4-A.8			
App.4-A.9			
App.4-A.10			
App.4-A.11			

<u>PAGE</u>	<u>CO</u>	<u>DE</u>	<u>DATE</u>
Appendix 4-C (cont)			
App. 4-C.12			
App. 4-C.13			
App. 4-C.14			
Appendix 4-D			
App. 4-D.i			
App. 4-D.ii			
App. 4-D.1			
App. 4-D.2			
App. 4-D.3			
App. 4-A.4			
Appendix 4-E			
App.4-E.i			
App.4-E.ii			
App.4-E.1			
App.4-E.2			
App.4-E.3			
App.4-E.4			
App.4-E.5			
App.4-E.6			
App.4-E.7			
App.4-E.8			
App.4-E.9			
App.4-E.10			
App.4-E.11			
App.4-E.12			
App.4-E.13			
App.4-E.14			
App.4-E.15			
App.4-E.16			
App.4-E.17			
App.4-E.18			
Appendix 4-F			
App. 4-F.i			
App. 4-F.ii			
(Other pages supplied by specific manufacturer) **			
Appendix 4-G			
App. 4-G.i			
App. 4-G.ii			
(Other pages supplied by specific manufacturer) **			

CODE: Original issue unless otherwise noted by R# = Revision number and date.[]

**Boeing and Douglas Model-Specific data are incorporated into this report.

*Revised Pages[]

4/9/93[]

Page 4 of 5[]

R1

<u>PAGE</u>	<u>CO</u>	<u>DE</u>	<u>DATE</u>
Appendix 4-H			
		App.4-H.i	
		App.4-H.ii	
		(Other pages supplied by specific manufacturers) **	
Appendix 4-I			
		App.4-I.i	
		App.4-I.ii	
		(Other pages supplied by specific manufacturers) **	
Appendix 4-J			
		App.4-J.i	
		App.4-J.ii	
		(Other pages supplied by specific manufacturers) **	
Index			
		i	
		ii	
		iii	
		iv	
		v	
		vi	

CODE: Original issue unless otherwise noted by R# = Revision number and date.□

**Boeing and Douglas Model-Specific data are incorporated into this report.

*Revised Pages□

4/9/93□

Page 5 of 5□

R1

(This page intentionally left blank)

Takeoff Safety Training Aid

Table of Contents

Section	Page
1	Takeoff Safety - Overview for Management1.i
1.0	Introduction1.1
1.1	General Goal sand Objectives1.2
1.2	Documentation Overview1.2
1.3	Industry Consensus1.3
1.4	Resource Utilization1.3
1.4	Conclusion1.3
2	Pilot Guide to Takeoff Safety2.i
2.0	Introduction2.1
2.1	Objectives2.1
2.2	"Successful versus unsuccessful" Go/No Go decisions2.1
2.2.1	An inservice perspective on Go/No Go decisions2.2
2.2.2	"Successful" Go/No Go decisions2.3
2.2.3	RTO overrun accidents and incidents2.4
2.2.4	Statistics2.5
2.2.5	Lessons learned2.7
2.3	Decisions and Procedures -- What every pilot should know2.8
2.3.1	The takeoff rules -- the source of the data2.8
2.3.2	Transition to the stopping configuration2.12
2.3.3	Comparing the "Stop" and "Go" Margins2.15
2.3.4	Operational takeoff calculations2.18
2.3.5	Factors that affect takeoff and RTO performance2.19
2.3.6	Increasing the RTO safety margins2.35
2.4	Crew Resource Management (CRM)2.41
2.4.1	CRM and the RTO2.41
2.4.2	The takeoff briefing2.41
2.4.3	Callouts2.42
2.4.4	The use of all crew members2.42
2.4.5	Summary2.42
3	Example Takeoff Safety Training Program3.i
3.0	Introduction3.1
3.1	Academic Training Program3.2
3.1.1	Training Objectives3.2
3.1.2	Academic Training Program Modules3.2
3.1.3	Academic Training Syllabus3.2
3.1.4	Additional Academic Training Resources3.3
3.2	Simulator Training Program3.3
3.2.1	Training Objectives3.3
3.2.2	Simulator Training Syllabus3.4
3.2.3	Pilot Simulator Briefing3.6
3.2.4	Simulator Exercises3.6
3.2.5	Exercises With Other Models3.14

Section	Page
3	Example Takeoff Safety Training Program (continued)
3.3	Simulator Implementation Guide3.15
3.3.1	Simulator Fidelity Checks3.15
3.3.2	Tuning for Accomplishments of Objectives3.15
3.3.3	Grooved Runways3.15
	Appendix 3-A Instructor Pilot Syllabus Briefing Supplement
	Appendix 3-B Pilot Guide to Takeoff Safety Questions
	Appendix 3-C Takeoff Safety Briefing
	Appendix 3-D Simulator Exercises
	Appendix 3-E Takeoff Safety Video Script, <i>Rejected Takeoff and the Go/No Go Decision</i>
4	Takeoff Safety Background Data 4.i
4.0	Introduction 4.1
4.1	Objectives 4.1
4.2	"Successful versus unsuccessful" Go/No Go decisions 4.2
4.2.1	An inservice perspective on Go/No Go decisions 4.2
4.2.2	"Successful" Go/No Go decisions 4.3
4.2.3	RTO overrun accidents and incidents 4.5
4.2.4	Statistics 4.6
4.2.5	Lessons learned 4.8
4.3	Decisions and Procedures -- What every pilot should know 4.9
4.3.1	The takeoff rules -- the source of the data 4.9
4.3.2	Transition to the stopping configuration 4.13
4.3.3	Comparing the "Stop" and "Go" Margins 4.15
4.3.4	Operational takeoff calculations 4.19
4.3.5	Factors that affect takeoff and RTO performance 4.21
4.3.6	Increasing the RTO safety margins 4.42
4.4	Crew Resource Management (CRM) 4.51
4.4.1	CRM and the RTO 4.51
4.4.2	The takeoff briefing 4.51
4.4.3	Callouts 4.53
4.4.4	The use of all crew members 4.53
4.4.5	Summary 4.53
	Appendix 4-A NTSB Special Investigation Report SIR -90/02
	Appendix 4-B RTO Accident/Incident List 1959 to 1990
	Appendix 4-C Other Takeoff Rules
	Appendix 4-D Reverse Thrust Effectiveness
	Appendix 4-E Takeoff Safety Training Aid Human Performance Study
	Appendix 4-F Airplane Flight Manual Transition Time Details
	Appendix 4-G Brake Pedal Force Data
	Appendix 4-H Reduced Thrust and Reduced V ₁ Examples
	Appendix 4-I Lineup Distance Charts
	Appendix 4-J The Effect of Procedural Variations On Stopping Distance

1

RTO Safety Overview for Management

TAKEOFF
SAFETY
TRAINING AID

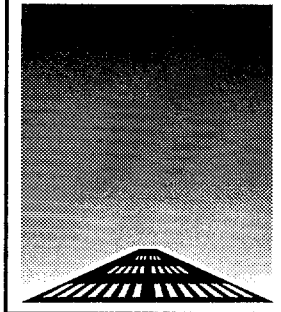

(This page intentionally left blank)

Takeoff Safety - Overview for Management Table of Contents



Section	Page
1.0 Introduction	1.1
1.1 General Goal and Objectives	1.2
1.2 Documentation Overview	1.2
1.3 Industry Consensus	1.3
1.4 Resource Utilization	1.3
1.5 Conclusion	1.3

(This page intentionally left blank)

Takeoff Safety - Overview for Management

1.0 Introduction

Airframe manufacturers, airlines, pilot groups, and government and regulatory agencies, have developed this training resource dedicated to reducing the number of rejected takeoff (RTO) accidents. The training package consists primarily of this document. However, a companion video developed by the Training Aid Working Group is also available.

Rejected takeoff accidents have been and continue to be, a significant contributor to the worldwide commercial aviation accident statistics. The National Transportation Safety Board (NTSB), in a report on RTO overruns¹, stated that historical evidence from two decades of RTO-related accidents "suggests that pilots faced with unusual or unique situations may perform high-speed RTO's unnecessarily or may perform them improperly."

An Airline Transport Association (ATA)/Aerospace Industries Association (AIA) organized, all-industry team (the "RTO Safety Task Force"), studied past RTO overrun events and made nine recommendations to the U.S. Federal Aviation Administration (FAA) and Joint Airworthiness Authority (JAA) in 1990². Three of the recommendations dealt with the need for improved crew training and operational practices, and where it was lacking, improved simulator fidelity to support improved training.

Key points relating to the need for improved training can be summarized as follows:

- 1) Over half of the RTO accidents and incidents in the past thirty years, were initiated from a speed in excess of V_1 .
- 2) Approximately one-third were reported as having occurred on runways that were wet or contaminated with snow or ice.

- 3) Only slightly more than one-fourth of the accidents and incidents actually involved any loss of engine thrust.

- 4) Nearly one-fourth of the accidents and incidents were the result of wheel/tire failures.

- 5) Approximately 80 percent of the overrun events were avoidable.

Most of the participants in the RTO Safety Task Force conclude that the recommendations to enhance RTO training and operational practices have the highest probability of significantly improving the RTO safety record. They believe enhancing the pilot's understanding of airplane and human performance and providing the opportunity to experience a greater variety of realistic takeoff decision scenarios in simulators will result in pilots making better Go/No Go decisions and improve their RTO procedure execution.

This training aid is intended to be a comprehensive training package which airlines can present to their crews in a combination of classroom and simulator programs. It is structured in a manner which should allow either stand alone use, incorporation into existing programs, or customizing by the airline to meet its unique requirements. This document provides instructors with technical information on takeoff performance for specific airplanes in an operator's fleet.

Whether operators choose to adopt the *Takeoff Safety Training Aid* as the foundation of their RTO safety training program or extract portions of the material to enhance their existing training program, a significant and measurable return is expected. Major airlines who have takeoff safety training programs in place, are experiencing significantly fewer unnecessary high speed rejected takeoffs and their passengers, crews and equipment are exposed to fewer potentially dangerous events.

¹ Section 4, Appendix A, NTSB/SIR-90/02 Special Investigation Report—Runway Overruns Following High Speed Rejected Takeoffs, 27 February 1990.

² ATA letter to the FAA, Standardization of FAA and JAA Rules For Certification of Aircraft Takeoff Performance, April 5, 1990.

It is anticipated that the cost of implementing this enhanced training will be minimal. An operator who is already doing a credible job of training flight crews will find the implementation of the training aid to be principally a change in emphasis, not a replacement of existing training syllabi. Except in unique instances where training devices may need upgrading to address significant pre-existing limitations, there should be virtually no hardware costs associated with this improved takeoff training.

In the final analysis, the pilots operating the flight are the ones who must make the Go/No Go decision and when necessary, carry out a successful RTO. They need appropriate training to assure that they can and will do the best job in the very difficult task of performing a high speed RTO. Achieving this objective of having flight crews well prepared for a possible RTO requires it to be a high priority of top management.

1.1 General Goal and Objectives

The goal of the *Takeoff Safety Training Aid* is to reduce the number of RTO related accidents and incidents by improving the pilot's decision making and associated procedure accomplishment through increased knowledge and awareness of the factors affecting the successful outcome of the Go/No Go decision. Objectives in support of this goal are to:

- 1) Establish an industry-wide consensus on effective Go/No Go decision training methods.
- 2) Develop appropriate educational material.
- 3) Develop an example training program, thereby providing a basis from which individual airlines may develop their own programs.

1.2 Documentation Overview

In addition to the Takeoff Safety - Overview for Management, the *Takeoff Safety Training Aid* package consists of the following:

Section 2	Pilot Guide to Takeoff Safety
Section 3	Example Takeoff Safety Training Program
Section 4	Takeoff Safety - Background Data
Video (optional)	<i>Rejected Takeoff and the Go/No Go Decision</i>

Section 2 Pilot Guide to Takeoff Safety, summarizes the material from Section 4 (Background Data) and is organized in a like manner to facilitate cross-referencing. The guide is a highly readable, concise treatment of pilot issues, written by pilots, for pilots. It is intended for self study or classroom use.

Section 3 Example Takeoff Safety Training Program, is a stand-alone resource designed to serve the needs of a training department. Both an example academic training program and an example simulator training program are included. Academic training lends itself to decision making education and planning strategies, while actual practice in making good takeoff decisions and correctly completing the appropriate procedures is best accomplished in the simulator.

The Simulator Implementation Guide addresses the verification of required simulator performance and possible "tuning" that might be required to insure accomplishment of the training program objectives. This section is offered as guidance for an airline's simulator technical staff.

Section 4 Takeoff Safety - Background Data, forms the basis for the document and provides technical reference material for the statements and recommendations in the training program. Section 4 includes information on:

- Past RTO overrun accidents and the lessons learned;

- A review of the basic factors involved in determining takeoff weights and speeds;
- A review of the atmospheric, airplane configuration, runway, and human performance factors that affect takeoff performance;
- A summary of what the flight crew can do to increase safety margins of every takeoff;
- The results of the Human Performance Simulator Study conducted as a part of the development of the training aid.

This section is written in as generic a manner as possible, subject to the limitation that specific airplane model data is occasionally required to make meaningful examples. However, an additional objective of Section 4 is to be a definitive source of information to the airline instructors with respect to the correct data on takeoff related subjects for all the airplane models operated by the airline. For this reason, space has been provided for the insertion of data from airframe manufacturers. Operators who desire this model specific data should contact the appropriate manufacturers.

Video Program (optional) - *Rejected Takeoff and the Go/No Go Decision*, is intended for use in an academic program in conjunction with Section 2, the Pilot Guide. Although the video is specifically designed to be used in a pilot briefing scenario, it can also be used to heighten the takeoff safety awareness of all people in an airline who are involved in areas which may contribute to the pilot needing to make a Go/No Go decision.

1.3 Industry Consensus

In the initial stages, those involved in defining the *Takeoff Safety Training Aid* included The Boeing Company, the Airline Transport Association, numerous airlines, the FAA, Air Line Pilots Association (ALPA), and the National Transportation Safety Board (NTSB). The fi-

nal draft reviews expanded the list to include many international airlines and regulatory agencies, and several other major airframe manufacturers. In all, a total of four review cycles were conducted, in which the comments and recommendations of all participants were considered for inclusion in the final material.

1.4 Resource Utilization

This document has been designed to be of maximum utility both in its current form and as a basis for an airline to design or modify its current programs as it sees fit.

Both academic and practical simulator training should be employed to achieve a well balanced, effective training program. For some operators, the adoption of the *Takeoff Safety Training Aid* into their existing training programs will require little more than a shift in emphasis. For those airlines that are in the process of formulating a complete training program, the *Takeoff Safety Training Aid* will readily provide the foundation of a thorough and efficient program.

The allocation of training time within recurrent and transition programs will vary from airline to airline. A typical program may be expected to consume a maximum of 15 minutes in each of four simulator sessions, backed up by at least one-half hour of academic training.

1.5 Conclusion

This document and the optional video are intended to assist all operators in creating or updating their own takeoff safety training program. Effective training in the areas of takeoff decision making and rejected takeoff procedure execution will reduce RTO overrun accidents and incidents. Management is encouraged to take appropriate steps to ensure that they have an effective takeoff safety training program.

(This page intentionally left blank)

2

Pilot Guide to Takeoff Safety

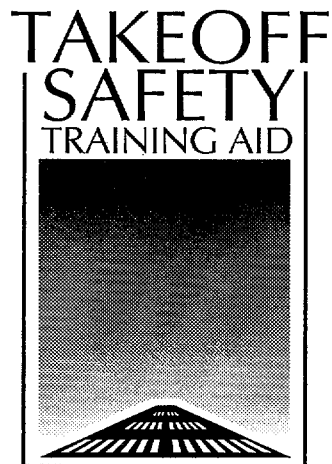

(This page intentionally left blank)

Pilot Guide to Takeoff Safety

Table of Contents

2

Section	Page
2.0	Introduction2.1
2.1	Objectives2.1
2.2	“Successful versus unsuccessful” Go/No Go decisions2.1
2.2.1	An inservice perspective on Go/No Go decisions2.2
2.2.2.	“Successful” Go/No Go decisions2.3
2.2.3.	RTO overrun accidents and incidents2.4
2.2.4.	Statistics2.5
2.2.5	Lessons learned2.7
2.3	Decisions and Procedures -- What every pilot should know2.8
2.3.1	The takeoff rules -- the source of the data2.8
2.3.1.1	The “FAR” takeoff field length2.9
2.3.1.2	V ₁ speed defined2.10
2.3.1.3	Balanced Field defined2.11
2.3.1.4	(Not Used)2.11
2.3.2	Transition to the stopping configuration2.12
2.3.2.1	Flight test transitions2.12
2.3.2.2	Airplane Flight Manual transition times2.12
2.3.3	Comparing the “Stop” and “Go” Margins2.15
2.3.3.1	The “Stop” margins2.15
2.3.3.2	The “Go” option2.16
2.3.4	Operational takeoff calculations2.18
2.3.4.1	The field length limit weight2.18
2.3.4.2	Actual weight less than limit weight2.19
2.3.5	Factors that affect takeoff and RTO performance2.19
2.3.5.1	Runway surface condition2.19
2.3.5.1.1	Hydroplaning2.20
2.3.5.1.2	The final stop2.21
2.3.5.2	Atmospheric conditions2.21
2.3.5.3	Airplane configuration2.22
2.3.5.3.1	Flaps2.22
2.3.5.3.2	Engine bleed air2.22
2.3.5.3.3	Missing or inoperative equipment2.22
2.3.5.3.4	Wheels, tires, and brakes2.24
2.3.5.3.5	Worn brakes2.27
2.3.5.3.6	Residual brake energy2.27
2.3.5.3.7	Speedbrake effect on wheel braking performance2.27
2.3.5.3.8	Carbon and Steel brake differences2.29
2.3.5.3.9	High brake energy RTO's2.31

Table of Contents (continued)

Section	Page
2.3.5	Factors that affect takeoff performance (continued)
2.3.5.4	Reverse thrust effects2.32
2.3.5.5	Runway parameters2.32
2.3.5.6	(Not used)
2.3.5.7	Takeoffs using reduced thrust2.34
2.3.5.8	Takeoff data the pilot sees2.35
2.3.6	Increasing the RTO safety margins2.35
2.3.6.1	Runway surface condition2.35
2.3.6.2	Flap selection2.36
2.3.6.3	Runway lineup2.37
2.3.6.4	Setting takeoff thrust2.37
2.3.6.5	Manual braking techniques2.38
2.3.6.6	Antiskid inoperative braking techniques2.39
2.3.6.7	RTO Autobrakes2.39
2.3.6.8	(Not used)
2.3.6.9	The V ₁ call2.40
2.3.6.10	Crew preparedness2.40
2.4	Crew Resource Management (CRM)2.41
2.4.1	CRM and the RTO2.41
2.4.2	The takeoff briefing2.41
2.4.3	Callouts2.42
2.4.4	The use of all crew members2.42
2.4.5	Summary2.42

Pilot Guide to Takeoff Safety

2

2.0 Introduction

The Pilot Guide to Takeoff Safety is one part of the *Takeoff Safety Training Aid*. The other parts include the Takeoff Safety Overview for Management (Section 1), Example Takeoff Safety Training Program (Section 3), Takeoff Safety Background Data (Section 4), and an optional video. The sub-section numbering used in Sections 2 and 4 are identical to facilitate cross referencing. Those sub-sections not used in Section 2 are noted "not used."

The goal of the training aid is to reduce the number of RTO related accidents by improving the pilot's decision making and associated procedural accomplishment through increased knowledge and awareness of the factors affecting the successful outcome of the "Go/No Go" decision.

The educational material and the recommendations provided in the *Takeoff Safety Training Aid* were developed through an extensive review process to achieve consensus of the air transport industry.

2.1 Objectives

The objective of the Pilot Guide to Takeoff Safety is to summarize and communicate key RTO related information relevant to flight crews. It is intended to be provided to pilots during academic training and to be retained for future use.

2.2 "Successful Versus Unsuccessful" Go/No Go Decisions

Any Go/No Go decision can be considered "successful" if it does not result in injury or airplane damage. However, just because it was "successful" by this definition, it does not mean the action was the "best" that could have been taken. The purpose of this section is to point out some of the lessons that have been learned through the RTO experiences of other airline crews over the past 30 years, and to recommend ways of avoiding similar experiences by the pilots of today's airline fleet.

Takeoffs, RTOs, and Overruns

	Through 1990	Projected 1995
Takeoffs	230,000,000	18,000,000
RTOs (est.)	76,000	6,000
RTO Overrun Accidents/Incidents	74	6

- 1 RTO per 3,000 takeoffs
- 1 RTO overrun accident/incident per 3,000,000 takeoffs

Figure 1
Takeoffs, RTOs,
and Overrun
Statistics

2.2.1 An Inservice Perspective On Go/No Go Decisions

Modern jet transport services began in the early 1950's and significantly increased later that decade after introduction of the Boeing 707 and the Douglas DC-8. As shown in Figure 1, the western built jet transport fleet will have accumulated approximately 230 million takeoffs by the end of 1990. The projection for 1995 alone is nearly 18 million takeoffs. That's approximately 34 takeoffs every minute, every day!

Since no comprehensive fleet-wide records are available, it is difficult to identify the total number of RTO's that have occurred through-

out the jet era. However, based on those events which have been documented, our best estimate is that one in 3000 takeoff attempts ends with an RTO. At this rate, there will be nearly 6000 RTO's during the year 1995. That means that every day in 1995, 16 flight crews will perform an RTO. Statistically, at the rate of one RTO per 3000 takeoffs, a pilot who flies short-haul routes and makes 80 departures per month, will experience one RTO every three years. At the opposite extreme, the long-haul pilot making only eight departures per month will be faced with only one RTO every 30 years.

The probability that a pilot will ever be required to perform an RTO from high speed is even less, as is shown in Figure 2.

Figure 2
Distribution of RTO
Initiation Speeds

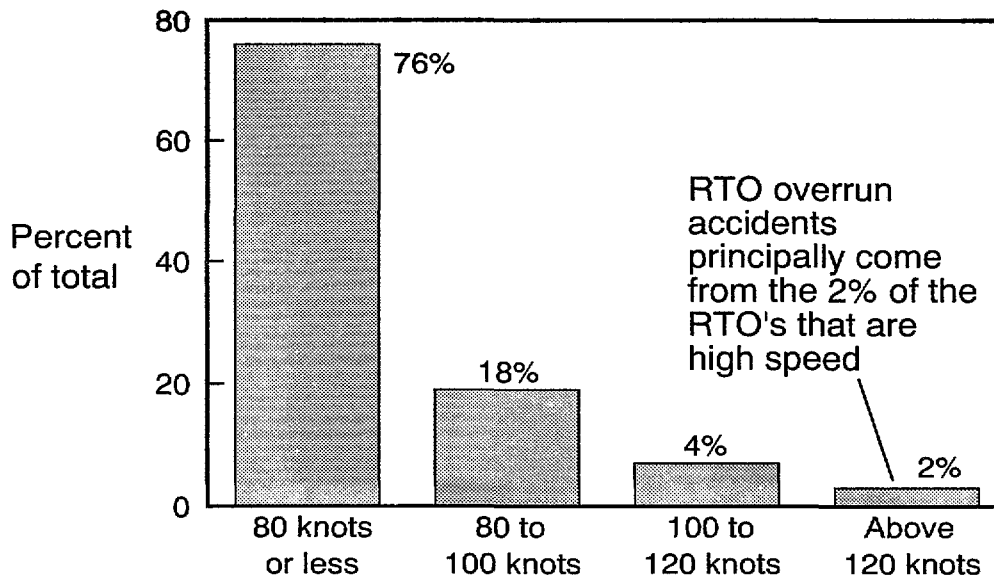

Available data indicates that over 75% of all RTO's are initiated at speeds of 80 knots or less. These RTO's almost never result in an accident. Inherently, low speed RTO's are safer and less demanding than high speed RTO's. At the other extreme, about 2% of the RTO's are initiated at speeds above 120 knots. Overrun accidents and incidents that occur principally stem from these high speed events.

What should all these statistics tell a pilot? First, RTO's are not a very common event. This speaks well of equipment reliability and the preparation that goes into operating jet transport airplanes. Both are, no doubt, due in large part to the certification and operational standards developed by the aviation community over the thirty plus years of operation. Second, and more important, the infrequency of RTO events may lead to complacency about maintaining sharp decision-making skills and procedural effectiveness. In spite of the equipment reliability, **every pilot must be prepared to make the correct Go/No Go decision on every takeoff — just in case.**

2.2.2 "Successful" Go/No Go Decisions

As was mentioned at the beginning of Section 2.2, there is more to a "good" Go/No Go decision than the fact that it may not have resulted in any apparent injury or aircraft damage. The following examples illustrate a variety of situations that have been encountered in the past, some of which would fit the description of a "good" decision, and some which are, at least, "questionable".

Listed at the beginning of each of the following examples, is the primary cause or cue which prompted the crew to reject the takeoff:

1. Takeoff Warning Horn: The takeoff warning horn sounded as the takeoff roll

commenced. The takeoff was rejected at 5 knots. The aircraft was taxied off the active runway where the captain discovered the stabilizer trim was set at the aft end of the green band. The stabilizer was reset and a second takeoff was completed without further difficulty.

2. Takeoff Warning Horn: The takeoff was rejected at 90 knots when the takeoff warning horn sounded. The crew found the speed brake lever slightly out of the detent. A normal takeoff was made following a delay for brake cooling.

3. Engine Power Setting: The throttles were advanced and N_1 increased to slightly over 95%. N_1 eventually stabilized at 94.8% N_1 . The target N_1 from the FMC Takeoff Page was 96.8% N_1 . The throttles were then moved to the firewall but the N_1 stayed at 94.8%. The takeoff was rejected due to low N_1 at 80 knots.

4. Compressor Stall: The takeoff was rejected from 155 knots due to a bird strike and subsequent compressor stall on the number three engine. Most of the tires subsequently deflated due to melted fuse plugs.

5. Nose Gear Shimmy: The crew rejected the takeoff after experiencing a nose landing gear shimmy. Airspeed at the time was approximately V_1-10 knots. All four main gear tires subsequently blew during the stop, and fires at the number 3 and 4 tires were extinguished by the fire department.

6. Blown Tire: The takeoff was rejected at 140 knots due to a blown number 3 main gear tire. Number 4 tire blew turning onto the taxiway causing the loss of both A and B hydraulic systems as well as major damage to flaps, spar, and spoilers.

These examples demonstrate the diversity of rejected takeoff causes. All of these RTO's were "successful", but some situations came very close to ending differently. By contrast, the large number of takeoffs that are successfully continued with indications of airplane system problems such as caution lights that illuminate at high speed or tires that fail near V_1 , are rarely ever reported outside the airline's own information system. They may result in diversions and delays but the landings are normally uneventful, and can be completed using standard procedures.

This should not be construed as a blanket recommendation to "Go, no matter what." The goal of this training aid is to eliminate RTO accidents by reducing the number of improper decisions that are made, and to ensure that the correct procedures are accomplished when an RTO is necessary. It is recognized that the kind of situations that occur in line operations are not always the simple problem that the pilot was exposed to in training. Inevitably, the resolution of some situations will only be possible through the good judgment and discretion of the pilot, as is exemplified in the following takeoff event:

After selecting EPR mode to set takeoff thrust, the right thrust lever stuck at 1.21 EPR, while the left thrust lever moved to the target EPR of 1.34. The captain tried to reject the takeoff but the right thrust lever could

not be moved to idle. Because the light weight aircraft was accelerating very rapidly, the Captain advanced the thrust on the left engine and continued the takeoff. The right engine was subsequently shut down during the approach, and the flight was concluded with an uneventful single-engine landing.

The failure that this crew experienced was not a standard training scenario. Nor is it included here to encourage pilots to change their mind in the middle of an RTO procedure. It is simply an acknowledgment of the kind of real world decision making situations that pilots face. It is perhaps more typical of the good judgements that airline crews regularly make, but the world rarely hears about.

2.2.3 RTO Overrun Accidents and Incidents

The one-in-one-thousand RTO's that became accidents or serious incidents are the ones that we must strive to prevent. As shown in Figure 3, at the end of 1990, records show 46 in service RTO overrun accidents for the western built jet transport fleet. These 46 accidents caused more than 400 fatalities. An additional 28 serious incidents have been identified which likely would have been accidents if the runway overrun areas had been less forgiving. The following are brief accounts of four actual accidents. They are real events. Hopefully, they will not be repeated.

Figure 3
74 RTO overrun
accidents/incidents
1959-1990

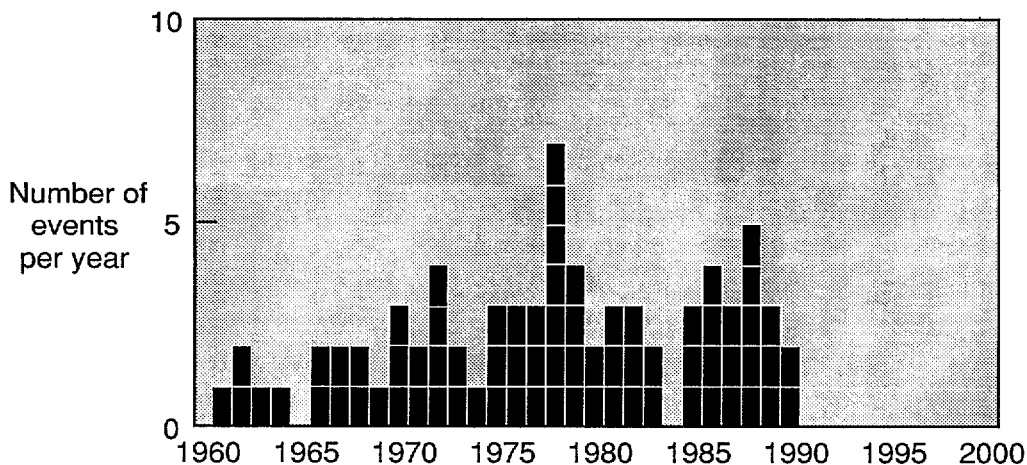

ACCIDENT: At 154 knots, four knots after V_1 , the copilot's side window opened, and the takeoff was rejected. The aircraft overran, hitting a blast fence, tearing open the left wing and catching fire.

ACCIDENT: The takeoff was rejected by the captain when the first officer had difficulty maintaining runway tracking along the 7000 foot wet runway. Initial reports indicate that the airplane had slowly accelerated at the start of the takeoff roll due to a delay in setting takeoff thrust. The cockpit voice recorder (CVR) readout indicates there were no speed callouts made during the takeoff attempt. The reject speed was 5 knots above V_1 . The transition to stopping was slower than expected. This was to have been the last flight in a long day for the crew. Both pilots were relatively inexperienced in their respective positions. The captain had about 140 hours as a captain in this airplane type and the first officer was conducting his first non-supervised line takeoff in this airplane type. The airplane was destroyed when it overran the end of the runway and broke apart against piers which extend off the end of the runway into the river. There were two fatalities. Subsequent investigation revealed that the rudder was trimmed full left prior to the takeoff attempt.

ACCIDENT: A flock of sea gulls was encountered "very near V_1 ." The airplane reportedly had begun to rotate. The number one engine surged and flamed out, and the takeoff was rejected. The airplane overran the end of the wet 6000 foot runway despite a good RTO effort.

ACCIDENT: At 120 knots, the flight crew noted the onset of a vibration. When the vibration increased, the captain elected to reject and assumed control. Four to eight seconds elapsed between the point where the vibration was first noted and when the RTO was initiated (just after V_1). Subsequent investigation showed two tires had failed. The maximum speed reached was 158 knots. The airplane overran the end of the runway at a speed of 35 knots and finally stopped with the nose in a swamp. The airplane was destroyed.

These four cases are typical of the 74 reported accidents and incidents.

2.2.4 Statistics

Studies of the previously mentioned 74 accidents/incidents have revealed some interesting statistics, as shown in Figure 4:

- Fifty-eight percent were initiated at speeds in excess of V_1 .
- Approximately one-third were reported as having occurred on runways that were wet or contaminated with snow or ice.

Both of these issues will be thoroughly discussed in subsequent sections. An additional, vitally interesting statistic that was observed when the accident records involving Go/No Go decisions were reviewed, was that virtually no revenue flight was found where a "Go"

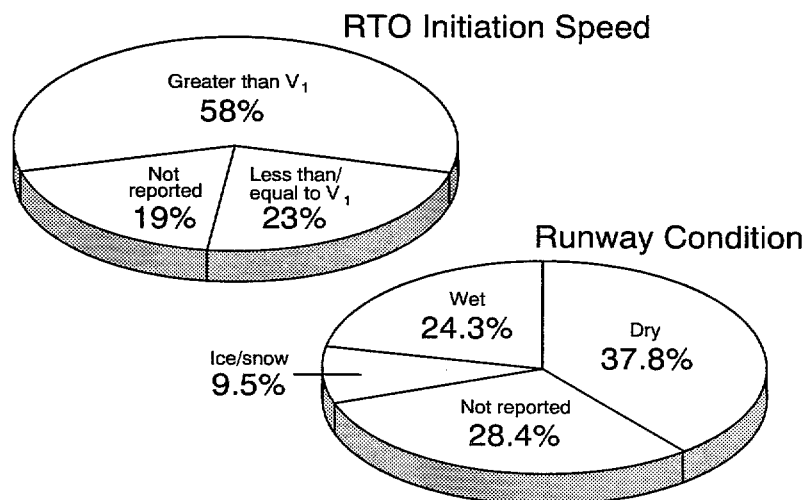
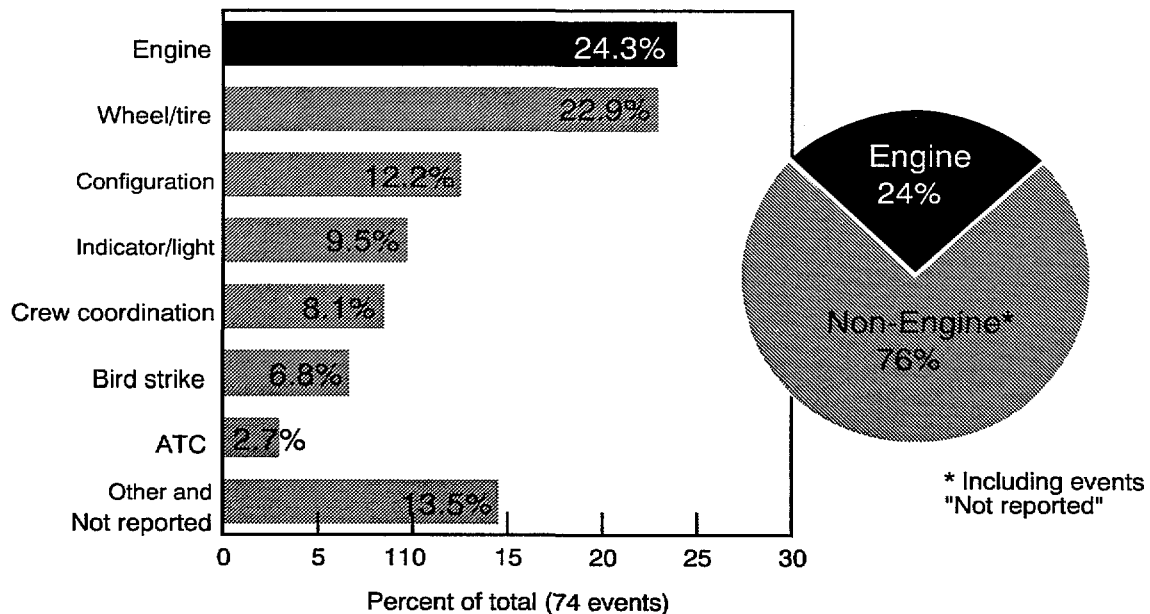

Figure 4
Major factors in
previous RTO
accidents

decision was made and the airplane was incapable of continuing the takeoff. Regardless of the ability to safely continue the takeoff, as will be seen in Section 2.3, virtually any takeoff can be "successfully" rejected, IF the reject is initiated early enough and is conducted properly. There is more to the Go/No Go decision than "Stop before V_1 " and "Go after V_1 ." The statistics of the past three decades show that a number of jet transports have experienced circumstances near V_1 that rendered the airplane incapable of being stopped on the runway remaining. It also must be recognized, that catastrophic situations could occur which render the airplane incapable of flight.

Reasons why the 74 "unsuccessful" RTO's were initiated are also of interest. As shown in Figure 5, approximately one-fourth were initiated because of engine failures or engine indication warnings. The remaining seventy-six percent were initiated for a variety of reasons which included tire failures, procedural error, malfunction indication or lights, noises and vibrations, directional control difficulties and unbalanced loading situations where the airplane failed to rotate. Some of the events contained multiple factors such as an RTO on a contaminated runway following an engine failure at a speed in excess of V_1 . The fact that the majority of the accidents and incidents occurred on airplanes that had full thrust available should figure heavily in future Go/No Go training.

Figure 5
Reasons for
initiating the RTO
(74 accident/
incident events)



2.2.5 Lessons Learned

Several lessons can be learned from these RTO accidents. First, the crew must always be prepared to make the Go/No Go decision prior to the airplane reaching V_1 speed. As will be shown in subsequent sections, there may not be enough runway left to successfully stop the airplane if the reject is initiated after V_1 . Second, in order to eliminate unnecessary RTO's, the crew must differentiate between situations that are detrimental to a safe take-off, and those that are not. Third, the crew must be prepared to act as a well-coordinated team. A good summarizing statement of these lessons is, **as speed approaches V_1 , the successful completion of an RTO becomes increasingly more difficult.**

A fourth and final lesson learned from the past 30 years of RTO history is illustrated in Figure 6. Analysis of the available data suggests that of the 74 RTO accidents and incidents, approximately 80% were potentially avoidable through appropriate operational practices. These potentially avoidable accidents can be divided into three categories. Roughly 9% of the RTO accidents of the past were the result of improper preflight planning. Some of these instances were caused by loading errors and others by incorrect preflight procedures. About 16% of the accidents and incidents could be attributed to incorrect pilot techniques or procedures in the stopping effort. Delayed application of the brakes, failure to deploy the speedbrakes, and the failure to make a maximum effort stop until late in the RTO were the chief characteristics of this category.

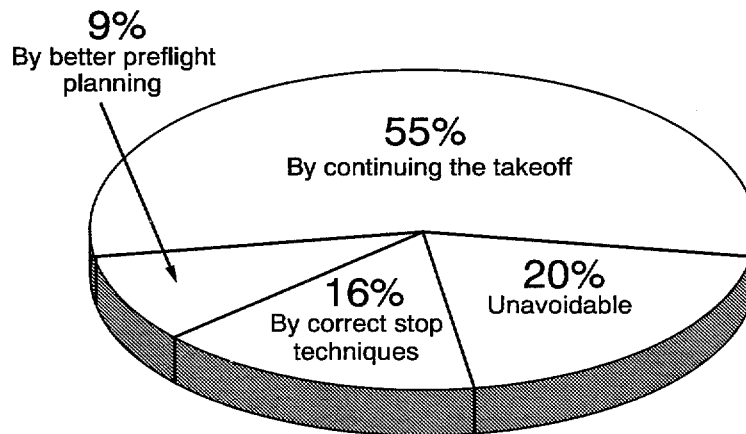

Figure 6
80% of the RTO
accidents were
avoidable

Review of the data from the 74 RTO accidents and incidents suggests that in approximately 55% of the events, the airplane was capable of continuing the takeoff and either landing at the departure airport or diverting to an alternate. In other words, the decision to reject the takeoff appears to have been "improper." It is not possible, however, to predict with total certainty what would have happened in every event if the takeoff had been continued. Nor is it possible for the analyst of the accident data to visualize the events leading up to a particular accident "through the eyes of the crew", including all the other factors that were vying for their attention at the moment when the "proper" decision could have been made. It is not very difficult to imagine a set of circumstances where the only logical thing for the pilot to do is to reject the takeoff. Encountering a large flock of birds at rotation speed, which then produces loss of thrust on both engines of a two-engine airplane, is a clear example.

Although these are all valid points, debating them here will not move us any closer to the goal of reducing the number of RTO accidents. Several industry groups have recently studied this problem. Their conclusions and recommendations agree surprisingly well. The areas identified as most in need of attention are decision making and proficiency in correctly performing the appropriate procedures. These are the same areas highlighted in Figure 6. It would appear then, that an opportunity exists to significantly reduce the number of RTO accidents in the future by attempting to improve the pilots' decision making capability and procedure accomplishment, through better training.

2.3 Decisions and Procedures - - What Every Pilot Should Know

There are many things that may ultimately affect the outcome of a Go/No Go decision.

The goal of the *Takeoff Safety Training Aid* is to reduce the number of RTO related accidents and incidents by improving the pilot's decision making and associated procedure accomplishment through increased knowledge and awareness of the related factors. This section discusses the rules that define takeoff performance limit weights and the margins that exist when the actual takeoff weight of the airplane is less than the limit weight. The effects of runway surface condition, atmospheric conditions, and airplane configuration variables on Go/No Go performance are discussed, as well as what the pilot can do to make the best use of any excess available runway.

Although the information contained in this section has been reviewed by many major airframe manufacturers and airlines, the incorporation of any of the recommendations made in this section are subject to the approval of each operator's management.

2.3.1 The Takeoff Rules - - The Source of the Data

It is important that all pilots understand the takeoff field length / weight limit rules and the margins these rules provide. Misunderstanding the rules and their application to the operational situation could contribute to an incorrect Go/No Go decision.

The U.S. Federal Aviation Regulations (FAR's) have continually been refined so that the details of the rules that are applied to one airplane model may differ from another. However, these differences are minor and have no effect on the basic actions required of the flight crew during the takeoff. In general, it is more important for the crew to understand the basic principles rather than the technical variations in certification policies.

2.3.1.1 The "FAR" Takeoff Field Length

The "FAR" Takeoff Field Length determined from the FAA Approved Airplane Flight Manual (AFM), considers the most limiting of each of the following three criteria:

- 1) All-Engine Go Distance: 115% of the actual distance required to accelerate, liftoff and reach a point 35 feet above the runway with all engines operating (Figure 7).
- 2) Engine-Out Accelerate-Go Distance: The distance required to accelerate with all engines operating, have one engine fail at V_{EF} , at least one second before V_1 , continue the takeoff, liftoff and reach a point 35 feet above the runway surface at V_2 speed (Figure 8).
- 3) Engine-Out Accelerate-Stop Distance: The distance required to accelerate with all engines operating, have an engine fail at V_{EF} , at least one second before V_1 , recognize the failure, reconfigure for stopping and bring the airplane to a stop using maximum wheel braking with the speed-

brakes extended. Reverse thrust is not used to determine the FAR accelerate-stop distance (Figure 9).

The FAR criteria provide accountability for wind, runway slope, clearway and stopway. FAA approved takeoff data are based on the performance demonstrated on a smooth, dry runway. Separate advisory data for wet or contaminated runway conditions are published in the manufacturer's operational documents. These documents are used by many operators to derive wet or contaminated runway takeoff adjustments.

Other criteria define the performance weight limits for takeoff climb, obstacle clearance, tire speeds and maximum brake energy capability. Any of these other criteria can be the limiting factor which determines the maximum dispatch weight. However, the Field Length Limit Weight and the amount of runway remaining at V_1 will be the primary focus of our discussion here since they more directly relate to preventing RTO overruns.

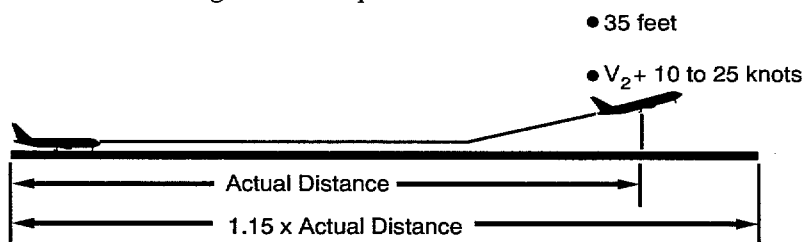

Figure 7
All-engine go
distance

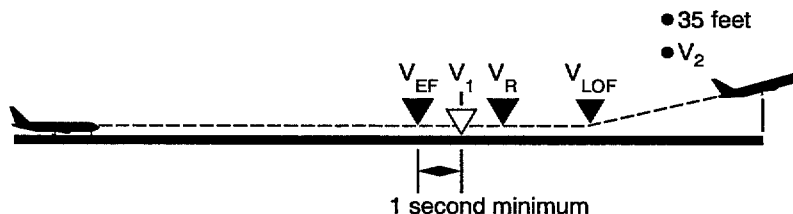

Figure 8
Engine-out
accelerate-go
distance

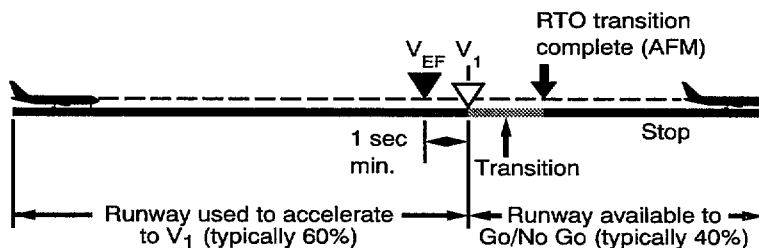
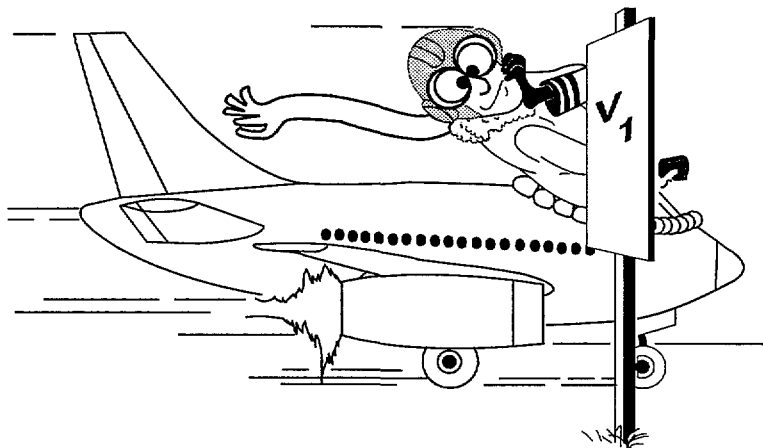

Figure 9
Engine-out
accelerate-stop
distance

2.3.1.2 V_1 Speed Defined

What is the proper operational meaning of the key parameter " V_1 speed" with regard to the Go/No Go criteria? This is not such an easy question since the term " V_1 speed" has been redefined several times since commercial jet operations began more than 30 years ago and there is possible ambiguity in the interpretation of the words used to define V_1 .

Paragraph 25.107 of the FAA Regulations defines the relationship of the takeoff speeds published in the Airplane Flight Manual, to various speeds determined in the certification testing of the airplane. Although the terms engine failure speed, decision speed, recognizes, and reacts are all within this "official" definition, for our purposes here, the most important statement within this "official" definition is that V_1 is determined from "**...the pilot's application of the first retarding means during the accelerate-stop tests.**"

One common and misleading way to think of V_1 is to say " V_1 is the decision speed." This is misleading because V_1 is not the point to begin making the operational Go/No Go decision. **The decision must have been made by the time the airplane reaches V_1 or the pilot will not have initiated the RTO procedure at V_1 .** Therefore, by definition, the airplane will be traveling at a speed higher than V_1 when stopping action is initiated, and if the airplane is at a Field Length Limit Weight, an overrun is virtually assured.

Another commonly held misconception: " V_1 is the engine failure recognition speed", suggests that the decision to reject the takeoff following engine failure recognition may begin as late as V_1 . Again, the airplane will have accelerated to a speed higher than V_1 before stopping action is initiated.

The certified accelerate-stop distance calculation is based on an engine failure at least one second prior to V_1 . This standard time allowance¹ has been established to allow the line pilot to recognize an engine failure and begin the subsequent sequence of stopping actions.

In an operational Field Length Limited context, the correct definition of V_1 consists of two separate concepts:

First, with respect to the "No Go" criteria, **V_1 is the maximum speed at which the rejected takeoff maneuver can be initiated and the airplane stopped within the remaining field length under the conditions and procedures defined in the FAR's. It is the latest point in the takeoff roll where a stop can be initiated.**

Second, with respect to the "Go" criteria, **V_1 is also the earliest point from which an engine out takeoff can be continued and the airplane attain a height of 35 feet at the end of the runway.** This aspect of V_1 is discussed in a later section.

¹ The time interval between V_{EF} and V_1 is the longer of the flight test demonstrated time or one second. Therefore, in determining the scheduled accelerate-stop performance, one second is the minimum time that will exist between the engine failure and the first pilot stopping action.

The Go/No Go decision must be made before reaching V_1 . A “No Go” decision after passing V_1 will not leave sufficient runway remaining to stop if the takeoff weight is equal to the Field Length Limit Weight. When the airplane actual weight is less than the Field Length Limit Weight, it is possible to calculate the actual maximum speed from which the takeoff could be successfully rejected. However, few operators use such takeoff data presentations. It is therefore recommended that pilots consider V_1 to be a limit speed: Do not attempt an RTO once the airplane has passed V_1 unless the pilot has reason to conclude the airplane is unsafe or unable to fly. This recommendation should prevail no matter what runway length appears to remain after V_1 .

2.3.1.3 Balanced Field Defined

The previous two sections established the general relationship between the takeoff performance regulations and V_1 speed. This section provides a closer examination of how the choice of V_1 actually affects the takeoff performance in specific situations.

Since it is generally easier to change the weight of an airplane than it is to change the length of a runway, the discussion here will consider the effect of V_1 on the allowable takeoff weight from a fixed runway length.

The Continued Takeoff - - After an engine failure during the takeoff roll, the airplane must continue to accelerate on the remaining

engine(s), lift off and reach V_2 speed at 35 feet. The later in the takeoff roll that the engine fails, the heavier the airplane can be and still gain enough speed to meet this requirement. For the engine failure occurring approximately one second prior to V_1 , the relationship of the allowable engine-out go takeoff weight to V_1 would be as shown by the “Continued Takeoff” line in Figure 10. The higher the V_1 , the heavier the takeoff weight allowed.

The Rejected Takeoff - - On the stop side of the equation, the V_1 / weight trade has the opposite trend. The lower the V_1 , or the earlier in the takeoff roll the stop is initiated, the heavier the airplane can be, as indicated by the “Rejected Takeoff” line in Figure 10.

The point at which the “Continued and Rejected Takeoff” lines intersect is of special interest. It defines what is called a “Balanced Field Limit” takeoff. The name “Balanced Field” refers to the fact that the accelerate-go performance required is exactly equal to (or “balances”) the accelerate-stop performance required. From Figure 10 it can also be seen that at the “Balanced Field” point, the allowable Field Limit Takeoff Weight for the given runway is the maximum. The resulting unique value of V_1 is referred to as the “Balanced Field Limit V_1 Speed” and the associated takeoff weight is called the “Balanced Field Weight Limit.” This is the speed that is typically given to flight crews in handbooks or charts, by the onboard computer systems, or by dispatch.

2.3.1.4 (Not Used)

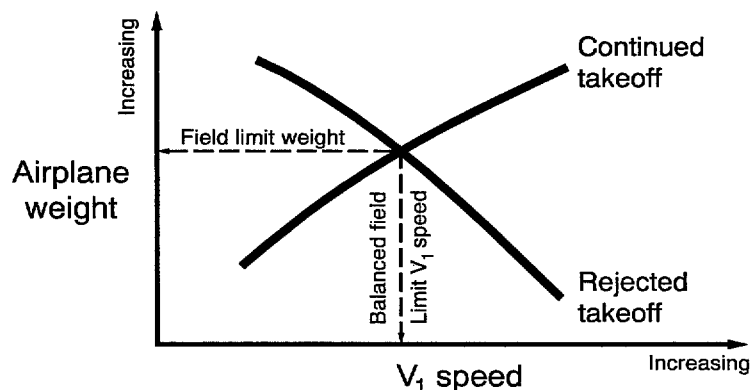

Figure 10
Effect of V_1 speed on takeoff weight (from a fixed runway length)

2.3.2 Transition to the Stopping Configuration

In establishing the certified accelerate-stop distance, the time required to reconfigure the airplane from the "Go" to the "Stop" mode is referred to as the "transition" segment. This action and the associated time of accomplishment includes applying maximum braking, simultaneously moving the thrust levers to idle and raising the speedbrakes. The transition time demonstrated by flight test pilots during the accelerate-stop testing is used to derive the transition segment times used in the AFM calculations. The relationship between the flight test demonstrated transition times and those finally used in the AFM is another frequently misunderstood area of RTO performance.

2.3.2.1 Flight Test Transitions

Several methods of certification testing that produce comparable results have been found to be acceptable. The following example illustrates the intent of these methods.

During certification testing, the airplane is accelerated to a pre-selected speed, one engine is "failed" by selecting fuel cut-off, and the pilot flying rejects the takeoff. In human factors circles, this is defined as a "simple task" because the test pilot knows in advance that an RTO will be performed. Exact measurements of the time taken by the pilot to apply the brakes, retard the thrust levers to idle, and to deploy the speedbrakes are recorded. Detailed measurements of engine parameters during spooldown are also made so that the thrust actually being generated can be accounted for in the calculation.

The manufacturer's test pilots, and pilots from the regulatory agency, each perform several rejected takeoff test runs. An average of the recorded data from at least six of these RTO's is then used to determine the "demonstrated" transition times. The total flight test "demonstrated" transition time, initial brake application to speedbrakes up, is typically one second or less. However this is not the total transition time used to establish the certified accelerate-stop distances. The certification regulations require that additional time delays, sometimes referred to as "pads", be included in the calculation of certified takeoff distances.

2.3.2.2 Airplane Flight Manual Transition Times

Although the line pilot must be prepared for an RTO during every takeoff, it is fairly likely that the event or failure prompting the Go/No Go decision will be much less clear-cut than an outright engine failure. It may therefore be unrealistic to expect the average line pilot to perform the transition in as little as one second in an operational environment. Human factors literature describes the line pilot's job as a "complex task" since the pilot does not know when an RTO will occur. In consideration of this "complex task", the flight test transition times are increased to calculate the certified accelerate-stop distances specified in the AFM. **These additional time increments are not intended to allow extra time for making the "No Go" decision after passing V_1 .** Their purpose is to allow sufficient time (and distance) for "the average pilot" to transition from the takeoff mode to the stopping mode.

The first adjustment is made to the time required to recognize the need to stop. During the RTO certification flight testing, the pilot knows that the engine will be failed, therefore, his reaction is predictably quick. To account for this, an engine failure recognition time of at least one second has been set as a standard for all jet transport certifications since the late 1960's. V_1 is therefore, at least one second after the engine failure. During this recognition time segment, the airplane continues to accelerate with the operating engine(s) continuing to provide full forward thrust. The "failed" engine has begun to spool down, but it is still providing some forward thrust, adding to the airplane's acceleration.

Over the years, the details of establishing the transition time segments after V_1 have varied slightly but the overall concept and the resulting transition distances have remained essentially the same. For early jet transport models, an additional one second was added to both the flight test demonstrated throttles-to-idle time and the speedbrakes-up time, as illustrated in Figure 11. The net result is that the flight test demonstrated recognition and transition time of approximately one second has been increased for the purpose of calculating the AFM transition distance.

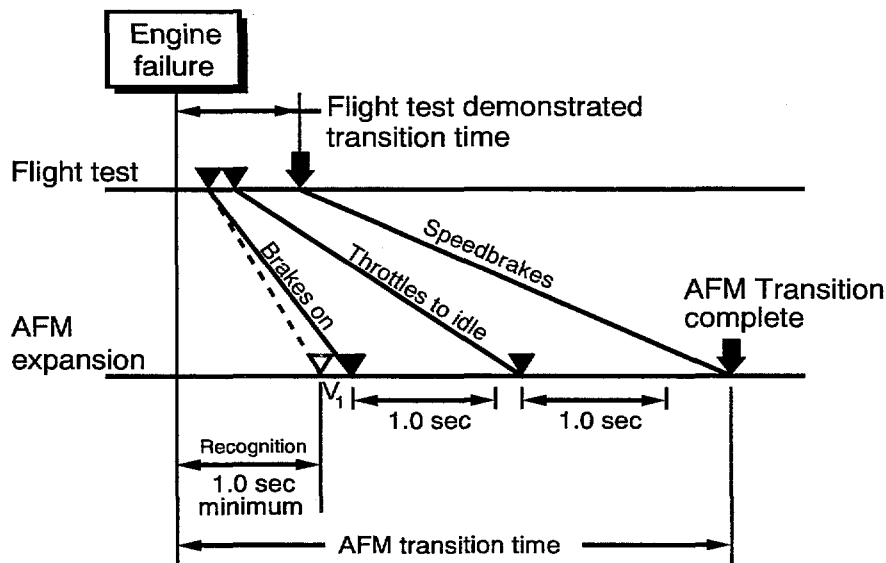

Figure 11
Early method of
establishing AFM
transition time

In more recent certification programs, the AFM calculation procedure was slightly different. An allowance equal to the distance traveled during two seconds at the speedbrakes-up speed was added to the actual total transition time demonstrated in the flight test to apply brakes, bring the thrust levers to idle and deploy the speedbrakes, as shown in Figure 12. To insure "consistent and repeatable results," retardation forces resulting from brake application and speed brake deployment are not applied during this two second allowance time, i.e. no deceleration credit is taken. This two second distance allowance simplifies the transition distance calculation and accomplishes the same goal as the individual one second "pads" used for older models.

Regardless of the method used, the accelerate - stop distance calculated for every takeoff from the AFM is typically 400 to 600 feet

longer than the flight test accelerate - stop distance.

These differences between the past and present methodology are not significant in so far as the operational accelerate-stop distance is concerned. **The key point is that the time/distance "pads" used in the AFM transition distance calculation are not intended to allow extra time to make the "No Go" decision.** Rather, the "pads" provide an allowance that assures the pilot has adequate distance to get the airplane into the full stopping configuration.

Regardless of the airplane model, the transition, or reconfiguring of the airplane for a rejected takeoff, demands quick action by the crew to simultaneously initiate maximum braking, retard the thrust levers to idle and then quickly raise the speedbrakes.

Figure 12
More recent method
of establishing AFM
transition time

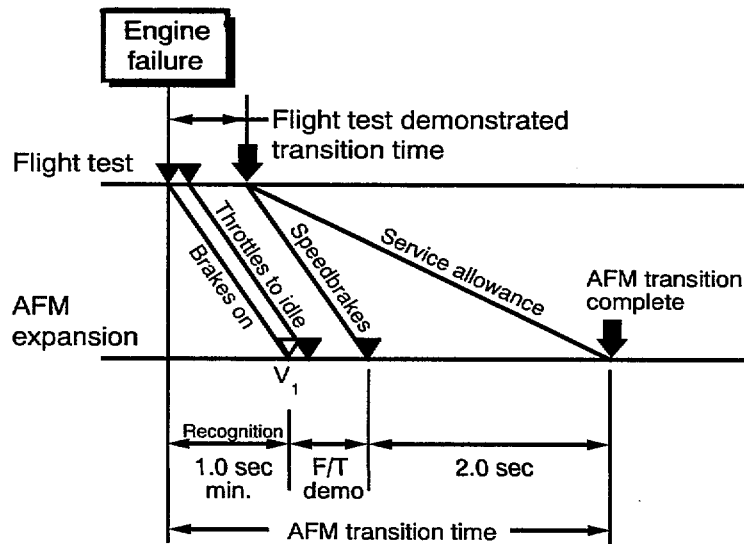

2.3.3 Comparing the "Stop" and "Go" Margins

When performing a takeoff at a Field Length Limit Weight determined from the AFM, the pilot is assured that the airplane performance will, at the minimum, conform to the requirements of the FAR's if the assumptions of the calculations are met. This means that following an engine failure at V_{EF} , the takeoff can be rejected at V_1 and the airplane stopped at the end of the runway, or if the takeoff is continued, a minimum height of 35 feet will be reached over the end of the runway.

This section discusses the inherent conservatism of these certified calculations, and the margins they provide beyond the required minimum performance.

2.3.3.1 The "Stop" Margins

From the preceding discussion of the certification rules, it has been shown that at a Field Length Limit Weight condition, an RTO initiated at V_1 will result in the airplane coming to a stop at the end of the runway. This accelerate-stop distance calculation specifies a smooth, dry runway, an engine failure at V_{EF} , the pilot's initiation of the RTO at V_1 , and the completion of the transition within the time allotted in the AFM. If any of these basic assumptions are not satisfied, the actual accelerate-stop distance may exceed the AFM calculated distance, and an overrun will result.

The most significant factor in these assumptions is the initiation of the RTO no later than V_1 , yet as was noted previously, in approximately 58% of the RTO accidents the stop was initiated after V_1 . At heavy weights near V_1 , the airplane is typically traveling at 200 to 300 feet per second, and accelerating at 3 to 6 knots per second. This means that a delay of only a second or two in initiating the RTO will require several hundred feet of additional runway to successfully complete the stop. If the takeoff was at a Field Limit Weight, and there is no excess runway available, the airplane will reach the end of the runway at a significant speed, as shown in Figure 13.

The horizontal axis of Figure 13 is the incremental speed in knots above V_1 at which a **maximum effort stop** is initiated. The vertical axis shows the **minimum speed** in knots at which the airplane would cross the end of the runway, assuming the pilot used all of the transition time allowed in the AFM to reconfigure the airplane to the stop configuration, and that a maximum stopping effort was maintained. The data in Figure 13 assumes an engine failure not less than one second prior to V_1 and does not include the use of reverse thrust. Therefore, if the pilot performs the transition more quickly than the AFM allotted time, and/or uses reverse thrust, the line labeled "MAXIMUM EFFORT STOP" would be shifted slightly to the right. However, based on the RTO accidents of the past, the shaded area above the line shows what is more likely to occur if a high speed RTO is initiated at or just after V_1 . This is especially true if the RTO

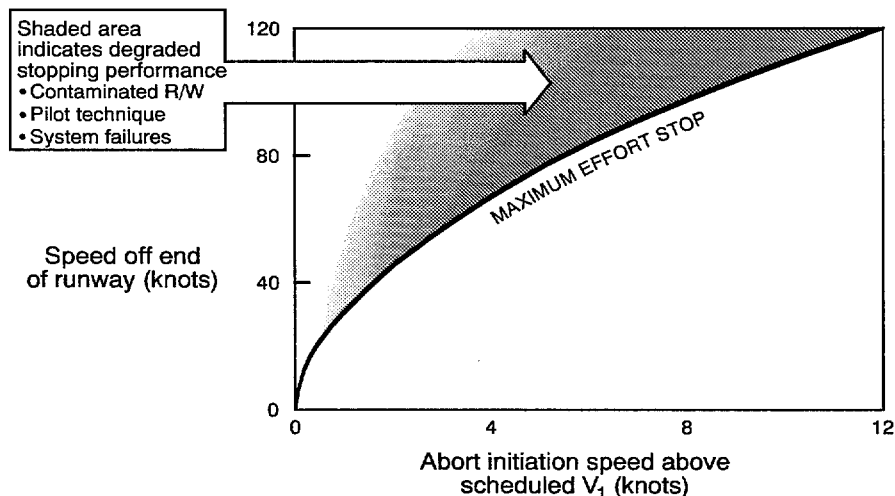

Figure 13
Overrun Speed
for an RTO
initiated after V_1

was due to something other than an engine failure, or if the stopping capability of the airplane is otherwise degraded by runway surface contamination, tire failures, or poor technique. The data in Figure 13 are typical of a large, heavy jet transport and would be rotated slightly to the right for the same airplane at a lighter weight.

In the final analysis, although the certified accelerate-stop distance calculations provide sufficient runway for a properly performed RTO on a dry runway, the available margins are fairly small. Most importantly, there are no margins to account for initiation of the RTO after V_1 or extenuating circumstances such as runway contamination.

2.3.3.2 The "Go" Option

FAR rules also prescribe minimum performance standards for the "Go" situation. With an engine failed at the most critical point along the takeoff path, the FAR "Go" criteria requires that the airplane be able to continue to accelerate, rotate, liftoff and reach V_2 speed at a point 35 feet above the end of the runway. The airplane must remain controllable throughout this maneuver and must meet certain minimum climb requirements. These handling characteristics and climb requirements are demonstrated many times throughout the certification flight test program. While a great deal of attention is focused on the engine failure case, it is important to keep in mind, that in nearly three-quarters of all RTO accident cases, full takeoff power was available. It is likely that each crew member has had a

good deal of practice in engine inoperative takeoffs in prior simulator or airplane training. However, it may have been done at relatively light training weights. As a result, the crew may conclude that large control inputs and rapid response typical of conditions near minimum control speeds (V_{mcg}) are always required in order to maintain directional control. However, at the V_1 speeds associated with a typical Field Length Limit Weight, the control input requirements are noticeably less than they are at lighter weights.

Also, at light gross weights, the airplane's rate of climb capability with one engine inoperative could nearly equal the all-engine climb performance at typical inservice weights, leading the crew to expect higher performance than the airplane will have if the actual airplane weight is at or near the takeoff Climb Limit Weight. Engine-out rate of climb and acceleration capability at a Climb Limit Weight may appear to be substantially less than the crew anticipates or is familiar with.

The minimum second segment climb gradients required in the regulations vary from 2.4% to 3.0% depending on the number of engines installed. These minimum climb gradients translate into a climb rate of only 350-500 feet per minute at actual climb limit weights and their associated V_2 speeds, as shown in Figure 14. The takeoff weight computations performed prior to takeoff are required to account for all obstacles in the takeoff flight path. All that is required to achieve the anticipated flight path is adherence by the flight crew to the planned headings and speeds per their pre-departure briefing.

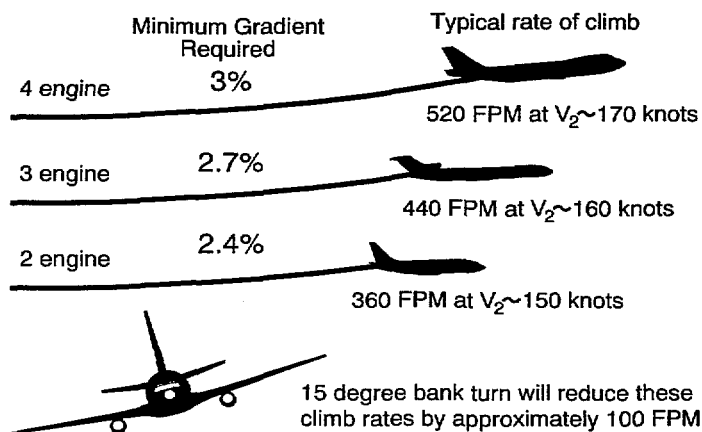

Figure 14
"GO" performance
at climb limit
weights

Consider a one-engine-inoperative case where the engine failure occurs earlier than the minimum time before V_1 specified in the rules. Because engine-out acceleration is less than all-engine acceleration, additional distance is needed to accelerate to V_R and, as a consequence, the liftoff point will be moved further down the runway. The altitude (or "screen height") achieved at the end of the runway is somewhat reduced depending on how much more than one second before V_1 the engine failure occurs. On a field length limit runway, the height at the end of the runway may be less than the 35 ft specified in the regulations.

Figure 15 graphically summarizes this discussion of "Go" margins. First, let V_{EF} be the speed at which the Airplane Flight Manual calculation assumes the engine to fail, (a minimum of one second before reaching V_1). The horizontal axis of Figure 15 shows the number of knots prior to V_{EF} that the engine actually fails instead of the time, and the vertical axis gives the "screen height" achieved at the end of the runway. A typical range of acceleration for jet transports is 3 to 6 knots per second, so the shaded area shows the range in screen height that might occur if the engine actually failed "one second early", or approximately two seconds prior to V_1 . In other words, a "Go" decision made with the engine failure occur-

ring two seconds prior to V_1 will result in a screen height of 15 to 30 feet for a Field Length Limit Weight takeoff.

Figure 15 also shows that the "Go" performance margins are strongly influenced by the number of engines. This is again the result of the larger proportion of thrust loss when one engine fails on the two-engine airplane compared to a three or four-engine airplane. On two-engine airplanes, there are still margins but they are not as large, a fact that an operator of several airplane types must be sure to emphasize in training and transition programs.

It should also be kept in mind that the 15 to 30 foot screen heights in the preceding discussion were based on the complete loss of thrust from one engine. If all engines are operating, as was the case in most of the RTO accident cases, the height over the end of the Field Length Limit runway will be approximately 150 feet and speed will be $V_2 + 10$ to 25 knots, depending on airplane type. This is due to the higher acceleration and climb gradient provided when all engines are operating and because the required all-engine takeoff distance is multiplied by 115%. If the "failed" engine is developing partial power, the performance is somewhere in between, but definitely above the required engine-out limits.

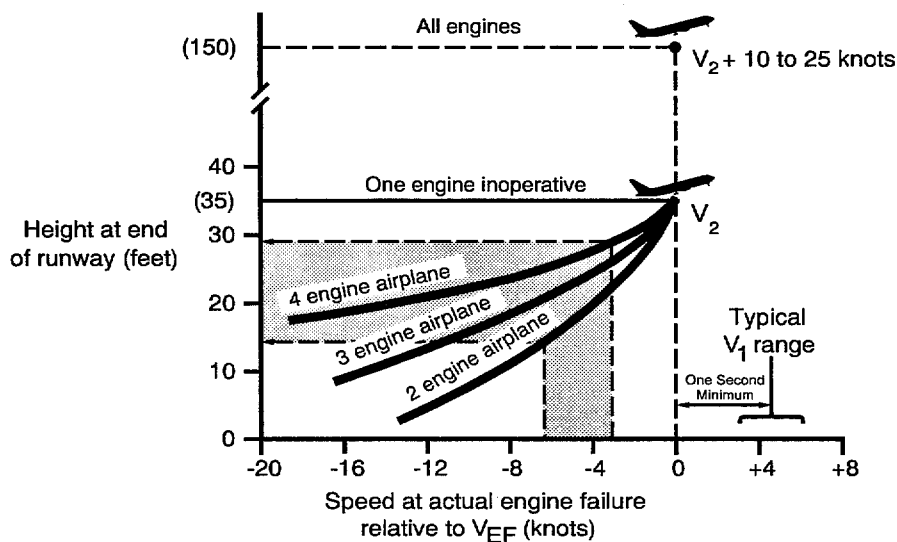

Figure 15
Effect of engine failure
before V_{EF}
on screen height

2.3.4 Operational Takeoff Calculations

As we have seen, the certification flight testing, in accordance with the appropriate government regulations, determines the relationship between the takeoff gross weight and the required runway length which is published in the AFM. By using the data in the AFM it is then possible to determine, for a given combination of ambient conditions and airplane weight, the required runway length which will comply with the regulations. Operational takeoff calculations, however, have an additional and obviously different limitation. The length of the runway is the Limit Field Length and it is fixed, not variable.

2.3.4.1 The Field Length Limit Weight

Instead of solving for the required runway length, the first step in an operational takeoff calculation is to determine the maximum airplane weight which meets the rules for the fixed runway length available. In other words, what is the limit weight at which the airplane:

- 1) will achieve 35 ft altitude with all engines operating and a margin of 15% of the actual distance used remaining;
- 2) will achieve 35 ft altitude with the critical engine failed prior to V_1 ;
- 3) will stop with an engine failed prior to V_1 and the reject initiated at V_1 ;

...all within the existing runway length available.

The result of this calculation is three allowable weights. These three weights may or may not be the same, but the lowest of the three becomes the Field Length Limit Weight for that takeoff.

An interesting observation can be made at this point as to which of these three criteria will typically determine the Takeoff Field Limit Weight for a given airplane type. Two-engine airplanes lose one-half their total thrust when an engine fails. As a result, the Field Length Limit Weight for two-engine airplanes is usu-

ally determined by one of the engine-out distance criteria. If it is limited by the accelerate-stop distance, there will be some margin in both the all-engine and accelerate-go distances. If the limit is the accelerate-go distance, some margin would be available for the all-engine-go and engine-out-stop cases.

By comparison, four-engine airplanes only lose one-fourth of their takeoff thrust when an engine fails so they are rarely limited by engine-out go performance. The Field Length Limit Weight for a four-engine airplane is typically limited by the 115% all-engine distance criteria or occasionally by the engine-out stop case. As a result, a slight margin frequently exists in both of the engine-out distances on four-engine airplanes.

Three-engine airplanes may be limited by engine out performance, or for some models, by a more complex criterion wherein the rotation speed V_R becomes the limiting factor. Since the regulations prohibit V_1 from exceeding V_R , some tri-jets frequently have $V_1 = V_R$, and a small margin may therefore exist in the accelerate-stop distance. Two-engine airplanes may occasionally be limited by this $V_1 = V_R$ criterion also.

The possible combinations of airport pressure altitude, temperature, wind, runway slope, clearway and stopway are endless. Regardless of airplane type, they can easily combine to make any one of the three previously discussed takeoff field length limits apply. Flight crews have no convenient method to determine which of the three criteria is limiting for a particular takeoff, and from a practical point of view, it really doesn't matter. The slight differences that may exist are rarely significant. Most RTO overrun accidents have occurred on runways where the airplane was not at a limit takeoff weight. That is, the accidents occurred on runways that were longer than required for the actual takeoff weight. Combining this historical evidence with the demanding nature of the high speed rejected takeoff, it would seem prudent that the crew should always assume the takeoff is limited by the accelerate-stop criteria when the takeoff weight is Field Length Limited.

2.3.4.2 Actual Weight Less Than Limit Weight

Returning to the operational takeoff calculation, the second step is to then compare the actual airplane weight to the Field Length Limit Weight. There are only two possible outcomes of this check.

- 1) The actual airplane weight could equal or exceed the Field Length Limit Weight, or
- 2) The actual airplane weight is less than the Field Length Limit Weight.

The first case is relatively straightforward, the airplane weight cannot be greater than the limit weight and must be reduced. The result is a takeoff at a Field Length Limit Weight as we have just discussed. The second case, which is typical of most jet transport operations, is worthy of further consideration.

By far, the most likely takeoff scenario for the line pilot is the case where the actual airplane weight is less than any limit weight, especially the Field Length Limit Weight. It also is possibly the most easily misunderstood area of takeoff performance since the fact that the airplane is not at a limit weight is about all the flight crew can determine from the data usually available on the flight deck. Currently, few operators provide any information that will let the crew determine how much excess runway is available; what it means in terms of the V_1 speed they are using; or how to best maximize the potential safety margins represented by the excess runway.

2.3.5 Factors that Affect Takeoff and RTO Performance

Both the continued and the rejected takeoff performance are directly affected by atmospheric conditions, airplane configuration, runway characteristics, engine thrust available, and by human performance factors. The following sections review the effects of these variables on airplane performance. The purpose is not to make this a complete treatise on airplane performance, rather, it is to emphasize that changes in these variables can have a significant impact on a successful Go/No Go

decision. In many instances, the flight crew has a degree of direct control over these changes.

2.3.5.1 Runway Surface Condition

The condition of the runway surface can have a significant effect on takeoff performance, since it can affect both the acceleration and deceleration capability of the airplane. The actual surface condition can vary from perfectly dry to a damp, wet, heavy rain, snow, or slush covered runway in a very short time. The entire length of the runway may not have the same stopping potential due to a variety of factors. Obviously, a 10,000 foot runway with the first 7,000 feet bare and dry, but the last 3,000 feet a sheet of ice, does not present a very good situation for a high speed RTO. On the other hand, there are also specially constructed runways with a grooved or Porous Friction Coat (PFC) surface which can offer improved braking under adverse conditions. The crews cannot control the weather like they can the airplane's configuration or thrust. Therefore, to maximize both the "Go" and "Stop" margins, they must rely on judiciously applying their company's wet or contaminated runway policies as well as their own understanding of how the performance of their airplane may be affected by a particular runway surface condition.

The certification testing is performed on a smooth, ungrooved, dry runway. Therefore, any contamination which reduces the available friction between the tire and the runway surface will increase the required stopping distance for an RTO. Runway contaminants such as slush or standing water can also affect the continued takeoff performance due to "displacement and impingement drag" associated with the spray from the tires striking the airplane. Some manufacturers provide advisory data for adjustment of takeoff weight and/or V_1 when the runway is wet or contaminated. Many operators use this data to provide flight crews with a method of determining the limit weights for slippery runways.

Factors that make a runway slippery and how they affect the stopping maneuver are discussed in the following sections.

2.3.5.1.1 Hydroplaning

Hydroplaning is an interesting subject since most pilots have either heard of or experienced instances of extremely poor braking action on wet runways during landing. The phenomenon is highly sensitive to speed which makes it an especially important consideration for RTO situations.

As a tire rolls on a wet runway, its forward motion tends to displace water from the tread contact area. While this isn't any problem at low speeds, at high speeds this displacement action can generate water pressures sufficient to lift and separate part of the tire contact area from the runway surface. The resulting tire-to-ground friction can be very low at high speeds but fortunately improves as speed decreases.

Dynamic hydroplaning is the term used to describe the reduction of tire tread contact area due to induced water pressure. At high speeds on runways with significant water, the forward motion of the wheel generates a wedge of high pressure water at the leading edge of the contact area, as shown in Figure 16A. Depending on the speed, depth of water, and certain tire parameters, the portion of the tire tread that can maintain contact with the runway varies significantly. As the tread contact area is reduced, the available braking friction is also reduced. This is the predominant factor leading to reduced friction on runways that have either slush, standing water or significant water depth due to heavy rain activity. In the extreme case, total dynamic hydroplaning can occur where the tire to runway contact area vanishes, the tire lifts off the runway and rides on the wedge of water like a water-ski. Since

the conditions required to initiate and sustain total dynamic hydroplaning are unusual, it is rarely encountered. When it does occur, such as during an extremely heavy rainstorm, it virtually eliminates any tire braking or cornering capability, at high speeds.

Another form of hydroplaning can occur where there is some tread contact with the runway surface but the wheel is either locked or rotating slowly (compared to the actual airplane speed). The friction produced by the skidding tire causes the tread material to become extremely hot. As indicated in Figure 16B, the resulting heat generates steam in the contact area which tends to provide additional upward pressure on the tire. The hot steam also starts reversing the vulcanizing process used in manufacturing the rubber tread material. The affected surface tread rubber becomes irregular in appearance, somewhat gummy in nature, and usually has a light gray color. This "reverted" rubber hydroplaning results in very low friction levels, approximately equal to icy runway friction when the temperature is near the melting point. An occurrence of reverted rubber hydroplaning is rare and usually results from some kind of antiskid system or brake malfunction which prevented the wheel from rotating at the proper speed.

In the last several years, many runways throughout the world have been grooved, thereby greatly improving the potential wet runway friction capability. As a result, the number of hydroplaning incidents has decreased considerably. Flight tests of one manufacturer's airplane on a well maintained grooved runway, which was thoroughly drenched with water, showed that the stopping forces were approximately 90% of the

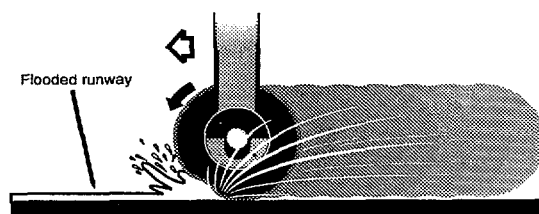

Dynamic Hydroplaning

Figure 16A

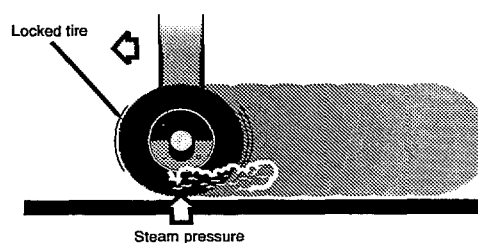

Reverted Rubber Hydroplaning

Figure 16B

forces that could be developed on a dry runway. Continued efforts to groove additional runways or the use of other equivalent treatments such as porous friction overlays, will significantly enhance the overall safety of takeoff operations.

The important thing to remember about wet or contaminated runway conditions is that for smooth runway surfaces there is a pronounced effect of forward ground speed on friction capability — aggravated by the depth of water. For properly maintained grooved or specially treated surfaces, the friction capability is markedly improved.

2.3.5.1.2 The Final Stop

A review of overrun accidents indicates that, in many cases, the stopping capability available was not used to the maximum during the initial and mid-portions of the stop maneuver, because there appeared to be “plenty of runway available”. In some cases, less than full reverse thrust was used and the brakes were released for a period of time, letting the airplane roll on the portion of the runway that would have produced good braking action. When the airplane moved onto the final portion of the runway, the crew discovered that the presence of moisture on the top of rubber deposits in the touchdown and turnoff areas resulted in very poor braking capability, and the airplane could not be stopped on the runway. When an RTO is initiated on wet or slippery runways, it is especially important to use full stopping capability until the airplane is completely stopped.

2.3.5.2 Atmospheric Conditions

In general, the lift the wings generate and thrust the engines produce are directly related to the airplane’s speed through the air and the density of that air. The flight crew should anticipate that the airplane’s takeoff performance will be affected by wind speed and direction as well as the atmospheric conditions which determine air density. Properly accounting for last minute changes in these factors is crucial to a successful Go/No Go decision.

The effect of the wind speed and direction on takeoff distance is very straightforward. At any given airspeed, a 10 knot headwind component lowers the ground speed by 10 knots. Since V_1 , rotation, and liftoff speeds are at lower ground speeds, the required takeoff distance is reduced. The opposite occurs if the wind has a 10 knot tailwind component, producing a 10 knot increase in the ground speed. The required runway length is increased, especially the distance required to stop the airplane from V_1 . Typical takeoff data supplied to the flight crew by their operations department will either provide takeoff weight adjustments to be applied to a zero wind limit weight or separate columns of limit weights for specific values of wind component. In either case, it is the responsibility of the flight crew to verify that last minute changes in the tower reported winds are included in their takeoff planning.

The effect of air density on takeoff performance is also straightforward in so far as the crew is normally provided the latest meteorological information prior to takeoff. However, it is the responsibility of the crew to verify the correct pressure altitude and temperature values used in determining the final takeoff limit weight and thrust setting.

2.3.5.3 Airplane Configuration

The planned configuration of the airplane at the time of takeoff must be taken into consideration by the flight crew during their takeoff planning. This should include the usual things like flap selection, and engine bleed configuration, as well as the unusual things like inoperative equipment covered by the Minimum Equipment List (MEL) or missing items as covered by the Configuration Deviation List (CDL). This section will discuss the effect of the airplane's configuration on takeoff performance capability and/or the procedures the flight crew would use to complete or reject the takeoff.

2.3.5.3.1 Flaps

The airplane's takeoff field length performance is affected by flap setting in a fairly obvious way. For a given runway length and airplane weight, the takeoff speeds are reduced by selecting a greater flap setting. This is because the lift required for flight is produced at a lower V_2 speed with the greater flap deflection. Since the airplane will reach the associated lower V_1 speed earlier in the takeoff roll, there will be more runway remaining for a possible stop maneuver. On the "Go" side of the decision, increasing the takeoff flap deflection will increase the airplane drag, and the resulting lower climb performance may limit the allowable takeoff weight. However, the takeoff analysis used by the flight crew will advise them if climb or obstacle clearance is a limiting factor with a greater flap setting.

2.3.5.3.2 Engine Bleed Air

Whenever bleed air is extracted from an engine and the value of the thrust setting parameter is appropriately reduced, the amount of thrust the engine generates is reduced. Therefore, the use of engine bleed air for air conditioning/pressurization reduces the airplane's potential takeoff performance for a given set of runway length, temperature and altitude conditions.

When required, using engine and/or wing anti-ice further decreases the performance on some airplane models. This "lost" thrust may be recoverable via increased takeoff EPR or N_1 limits as indicated in the airplane operating manual. It depends on engine type, airplane model, and the specific atmospheric conditions.

2.3.5.3.3 Missing or Inoperative Equipment

Inoperative or missing equipment can sometimes affect the airplane's acceleration or deceleration capability. Items which are allowed to be missing per the certified Configuration Deviation List (CDL), such as access panels and aerodynamic seals, can cause airplane drag to increase. The resulting decrements to the takeoff limit weights are, when appropriate, published in the CDL. With these decrements applied, the airplane's takeoff performance will be within the required distances and climb rates.

Inoperative equipment or deactivated systems, as permitted under the Minimum Equipment List (MEL) can also affect the airplane's dispatched "Go" or "Stop" performance. For instance, on some airplane models, an inoperative in-flight wheel braking system may require the landing gear to be left extended during a large portion of the climbout to allow the wheels to stop rotating. The "Go" performance calculations for dispatch must be made in accordance with certified "Landing Gear Down" Flight Manual data. The resulting new limit takeoff weight may be much less than the original limit in order to meet obstacle clearance requirements, and there would be some excess runway available for a rejected takeoff.

An MEL item that would not affect the "Go" performance margins but would definitely degrade the "Stop" margins is an inoperative anti-skid system. In this instance, not only is the limit weight reduced by the amount determined from the AFM data, but the flight crew may also be required to use a different

rejected takeoff procedure in which the throttles are retarded first, the speedbrakes deployed second, and then the brakes are applied in a judicious manner to avoid locking the wheels and failing the tires.³ The associated decrement in the Field Length Limit Weight is usually substantial.

Other MEL items such as a deactivated brake may impact both the continued takeoff and RTO performance through degraded braking capability and loss of in-flight braking of the spinning tire.

The flight crew should bear in mind that the performance of the airplane with these types of CDL or MEL items in the airplane's maintenance log at dispatch will be within the certified limits. However, it would be prudent for the flight crew to accept final responsibility to assure that the items are accounted for in the dispatch process, and to insure that they, as a crew, are prepared to properly execute any revised procedures.

³ U.K. CAA procedure adds "...apply maximum reverse thrust."

2.3.5.3.4 Wheels, Tires, and Brakes

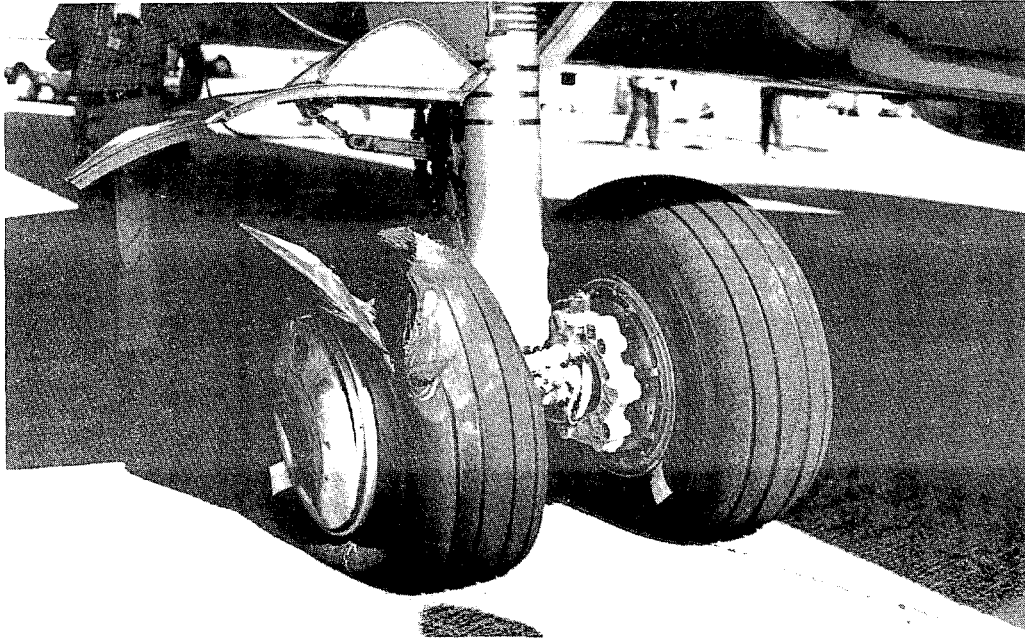

The airplane's wheels, tires, and brakes are another area that should be considered in light of the significant part they play in determining the results of a Go/No Go decision.

One design feature which involves all three components is the wheel fuse plug. All jet transport wheels used for braking incorporate thermal fuse plugs. The function of the fuse plug is to prevent tire or wheel bursts by melting if the heat transferred to the wheels from the brakes becomes excessive. Melting temperatures of fuse plugs are selected so that with excessive brake heat, the inflation gas (usually nitrogen) is released before the structural integrity of the tire or wheel is seriously impaired. Both certification limitations and operational recommendations to avoid melting fuse plugs are provided to operators by the manufacturer, as is discussed in Section 2.3.5.3.6 under the heading, Residual Brake Energy.

While fuse plugs provide protection from excessive brake heat, it is also important to recognize that fuse plugs cannot protect against all types of heat induced tire failures. The location of the fuse plug in the wheel is selected to ensure proper response to brake heat. This location in combination with the inherent low thermal conductivity of tire rubber means that the fuse plugs cannot prevent tire failures from the rapid internal heat buildup associated with taxiing on an underinflated tire. This type of heat buildup can cause a breakdown of the rubber compound, ply separation, and/or rupture of the plies. This damage might not cause immediate tire failure and because it is internal, it may not be obvious by visual inspection. However, the weakened tire is more prone to failure on a subsequent flight. Long taxi distances especially at high speeds and heavy takeoff weights can aggravate this problem and result in a blown tire. While underinflation is a maintenance issue, flight crews can at least minimize the possibility of tire failures due to overheating by using low taxi speeds and minimizing taxi braking whenever possible.

Correct tire inflation and fuse plug protection are significant, but will never prevent all tire failures. Foreign objects in parking areas, taxiways and runways can cause severe cuts in tires. The abrasion associated with sustained locked or skidding wheels, which can be caused by various antiskid or brake problems can grind through the tire cords until the tire is severely weakened or a blow-out occurs. Occasionally, wheel cracks develop which deflate a tire and generate an overloaded condition in the adjacent tire on the same axle. Some of these problems are inevitable. However, it cannot be overstressed that proper maintenance and thorough walk around inspections are key factors in preventing tire failures during the takeoff roll.

Tire failures may be difficult to identify from the flight deck and the related Go/No Go decision is therefore, not a simple task. A tire burst may be loud enough to be confused with an engine compressor stall, may just be a loud noise, or may not be heard. A tire failure may not be felt at all, may cause the airplane to pull to one side, or can cause the entire airplane to shake and shudder to the extent that instruments may become difficult to read. Vibration arising out of failure of a nosewheel tire potentially presents another complication. During takeoff rotation, vibration may actually increase at nosewheel liftoff due to the loss of the dampening effect of having the wheel in contact with the runway. A pilot must be cautious not to inappropriately conclude, under such circumstances, that another problem exists.

Although continuing a takeoff with a failed tire will generally have no significant adverse results, there may be additional complications as a result of a tire failure. Failed tires do not in themselves usually create directional control problems. Degradation of control can

occur, however, as a result of heavy pieces of tire material being thrown at very high velocities and causing damage to the exposed structure of the airplane and/or the loss of hydraulic systems. On airplanes with aft mounted engines, the possibility of pieces of the failed tire being thrown into an engine must also be considered.

An airplane's climb gradient and obstacle clearance performance with all engines operating and the landing gear down exceeds the minimum certified engine-out levels that are used to determine the takeoff performance limits. Therefore, leaving the gear down after a suspected tire failure will not jeopardize the aircraft if all engines are operating. However, if the perceived tire failure is accompanied by an indication of thrust loss, or if an engine problem should develop later in the takeoff sequence, the airplane's climb gradient and/or obstacle clearance capability may be significantly reduced if the landing gear is not retracted. The decision to retract the gear with a suspected tire problem should be in accordance with the airline's/manufacturer's recommendations.

If a tire failure is suspected at fairly low speeds, it should be treated the same as any other rejectable failure and the takeoff should be rejected promptly. When rejecting the takeoff with a blown tire, the crew should anticipate that additional tires may fail during the stop attempt and that directional control may be difficult. They should also be prepared for the possible loss of hydraulic systems which may cause speedbrake or thrust reverser problems. Since the stopping capability of the airplane may be significantly compromised, the crew should not relax from a maximum effort RTO until the airplane is stopped on the pavement.

Rejecting a takeoff from high speeds with a failed tire is a much riskier proposition, especially if the weight is near the Field Limit Weight. The chances of an overrun are increased simply due to the loss of braking force from one wheel. If additional tires should fail during the stop attempt, the available braking force is even further reduced. In this case, it is generally better to continue the takeoff, as can be seen in Figure 17. The subsequent landing may take advantage of a lower weight and speed if it is possible to dump fuel. Also, the crew will be better prepared for possible vibration and/or control problems. Most important, however, is the fact that the entire

runway will be available for the stop maneuver instead of perhaps, as little as 40% of it. As can be seen from this discussion, it is not a straightforward issue to define when a takeoff should be continued or rejected after a suspected tire failure. It is fairly obvious however, that an RTO initiated at high speed with a suspected tire failure is not a preferred situation. McDonnell Douglas Corporation, in a recent All Operator Letter⁴, has addressed this dilemma by recommending a policy of not rejecting a takeoff for a suspected tire failure at speeds above $V_1 - 20$ knots. The operators of other model aircraft should contact the manufacturer for specific recommendations regarding tire failures.

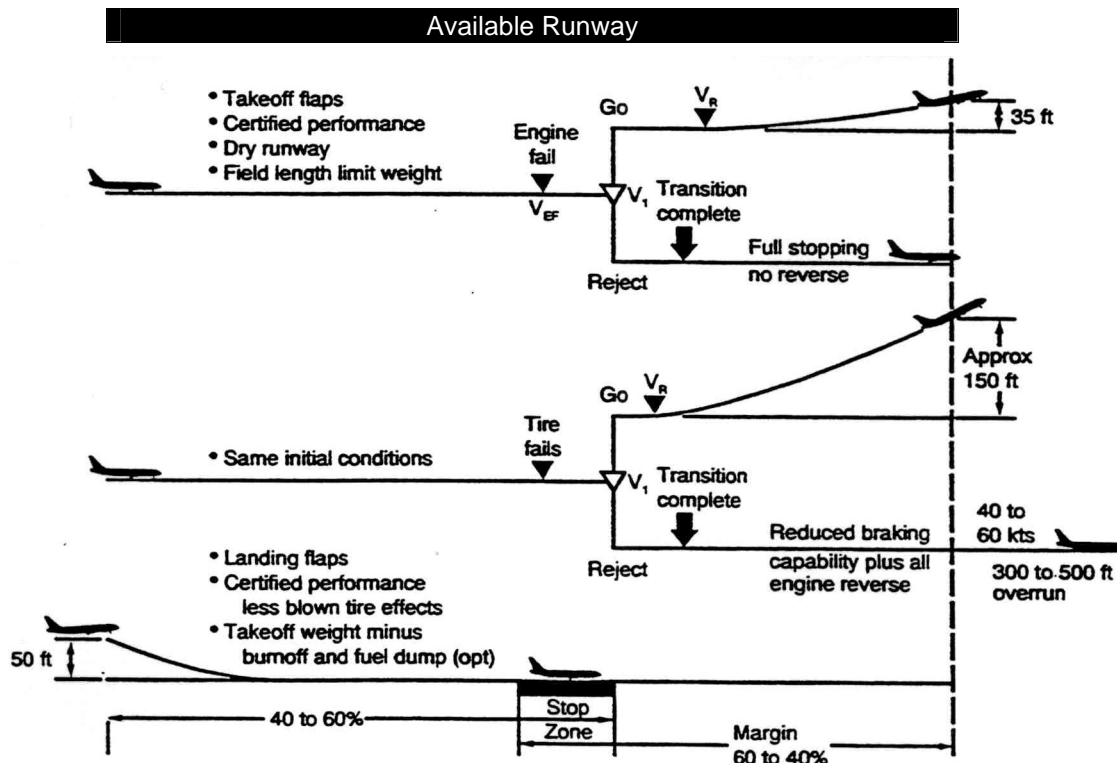

*Figure 17
Margins associated with continuing or rejecting a takeoff with a tire failure*

⁴ McDonnell Douglas All Operators Letter FO-AOL-8-003,-9-006,-10-004,-11-015, Reiteration of Procedures and Techniques Regarding Wheels Tires and Brakes, Dated 19 AUG 1991

2.3.5.3.5 Worn Brakes

The investigation of one recent RTO incident which was initiated "very near V_1 ", revealed that the overrun was the result of 8 of the 10 wheel brakes failing during the RTO. The failed brakes were later identified to have been at advanced states of wear which, while within accepted limits, did not have the capacity for a high energy RTO.

This was the first and only known accident in the history of commercial jet transport operation that can be traced to failure of the brakes during an attempted RTO. The National Transportation Safety Board (NTSB) investigated the accident and made several recommendations to the FAA. The recommendations included the need to require airplane and brake manufacturers to verify by test and analysis that their brakes, when worn to the recommended limits, meet the certification requirements. Prior to 1991, maximum brake energy limits had been derived from tests done with new brakes installed.

Virtually all brakes in use today have wear indicator pins to show the degree of wear and when the brake must be removed from the airplane. In most cases, as the brake wears, the pin moves closer to a reference point, so that when the end of the pin is flush with the reference (with full pressure applied), the brake is "worn out". As of late 1991, tests have been completed which show that brakes at the allowable wear limit can meet AFM brake energy levels. As a result, "wear pin length" is not significant to the flight crew unless the pin indicates that the brake is worn out and should be removed from service. There are no changes to flight crew or dispatch procedures based on brake wear pin length.

2.3.5.3.6 Residual Brake Energy

After a brake application, the energy which the brake has absorbed is released as heat and until this heat is dissipated, the amount of additional energy which the brake can absorb without failure is reduced. Therefore, takeoff planning must consider the effects of residual brake energy (or brake temperature) if the previous landing involved significant braking and/or the airplane turnaround is relatively

short. There are two primary sources of information on this subject. The brake temperature limitations and/or cooling charts in the airplane operating manual provide recommended information on temperature limitations and/or cooling times and the procedures necessary to dissipate various amounts of brake energy. In addition, the Maximum Quick Turnaround Weight (MQTW) chart in the AFM is a regulatory requirement that must be followed. This chart shows the gross weight at landing where the energy absorbed by the brakes during the landing could be high enough to cause the wheel fuse plugs to melt and establishes a minimum waiting/cooling time for these cases. The MQTW chart assumes that the previous landing was conducted with maximum braking for the entire stop and did not use reverse thrust, so for many landings where only light braking was used there is substantial conservatism built into the wait requirement.

2.3.5.3.7 Speedbrake Effect on Wheel Braking

While jet transport pilots generally understand the aerodynamic drag benefit of speedbrakes and the capability of wheel brakes to stop an airplane, the effect of speedbrakes on wheel brake effectiveness during an RTO is not always appreciated. The reason speedbrakes are so critical is their pronounced effect on wing lift. Depending on flap setting, the net wing lift can be reduced, eliminated or reversed to a down load by raising the speedbrakes, thereby increasing the vertical load on the wheels which in turn can greatly increase braking capability.

Speedbrakes are important since for most braking situations, especially any operation on slippery runways, the torque output of the brake, and therefore the amount of wheel brake retarding force that can be developed is highly dependent on the vertical wheel load. As a result, speedbrakes must be deployed early in the stop to maximize the braking capability. During RTO certification flight tests, the stopping performance is obtained with prompt deployment of the speedbrakes. **Failure to raise the speedbrakes during an RTO or raising them late will significantly increase the stopping distance beyond the value shown in the AFM.**

Figures 18 and 19 summarize the effect of speedbrakes during an RTO. For a typical mid-sized two-engine transport, at a takeoff weight of 225,000 lbs, the total load on the main wheels at brake release would be approximately 193,000 lbs. As the airplane accelerates along the runway, wing lift will decrease the load on the gear, and by the time the airplane approaches V_1 speed, (137 knots for this example), the main gear load will have decreased by nearly 63,000 lbs. The data in Figure 19 graphically depicts how the forces acting on the airplane vary with airspeed from a few knots before the RTO is initiated until the airplane is stopped. When the pilot begins the RTO by applying the brakes and closing the thrust levers, the braking force rises quickly to a value in excess of 70,000 lbs. The nearly vertical line made by the braking force curve in Figure 19 also shows that the airplane began to decelerate almost immediately, with virtually no further increase in speed.

The next action in a typical RTO procedure is to deploy the speedbrakes. By the time this action is completed, and the wheel brakes have become fully effective, the airplane will have slowed several knots. In this example of an RTO initiated at 137 knots, the airspeed would be about 124 knots at this point. The weight on the main gear at 124 knots would be approximately 141,600 lbs with the speedbrakes down, and would increase by 53,200 lbs when the speedbrakes are raised. The high speed braking capability is substantially improved by this 38% increase in wheel load from 141,600 to 194,800 pounds, which can be seen by noting the increase in braking

force to 98,000 pounds. In addition, the speedbrakes have an effect on aerodynamic drag, increasing it by 73%, from 8,500 to 14,700 pounds. The combined result, as indicated by the table in Figure 18, is that during the critical, high speed portion of the RTO, the total stopping force acting on the airplane is increased by 34% when the speedbrakes are deployed.

Since both the force the brakes can produce and the aerodynamic effect of the speedbrakes vary with speed, the total effect for the RTO stop is more properly indicated by averaging the effect of the speedbrakes over the entire stopping distance. For this example, the overall effect of raising the speedbrakes is an increase of 14% in the average total stopping force acting throughout the RTO.

One common misconception among pilots is that the quick use of thrust reversers will offset any delay or even the complete lack of speedbrake deployment during an RTO. This is simply not true. On a dry runway, delaying the deployment of the speedbrakes by only 5 seconds during the RTO will add over 300 ft. to the stop distance of a typical mid-sized two-engine jet transport, including the effects of engine-out reverse thrust. As a worst case illustration, if reverse thrust was not used and the speedbrakes were not deployed at all, the stopping distance would be increased by more than 700 ft. Although the exact figures of this example will vary with different flap settings and from one airplane model to another, the general effect will be the same, namely that speedbrakes have a very pronounced effect on stopping performance.

Figure 18
Effect of speedbrakes on the stopping capability of a typical mid-size two-engine transport

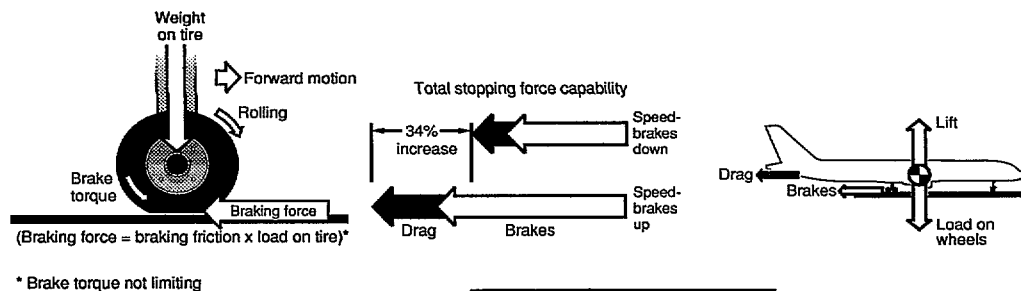

	Speedbrake position		Difference speedbrake up
	Down	Up	
Drag	8,500 lbs	14,700 lbs	+73%
Lift	52,000 lbs	-1,200	-102%
Net load on wheels	141,600	194,800	+38%
Max. braking force	75,900	98,000	+29%
Max. stopping force (brakes & drag)	84,400	112,700	+34%

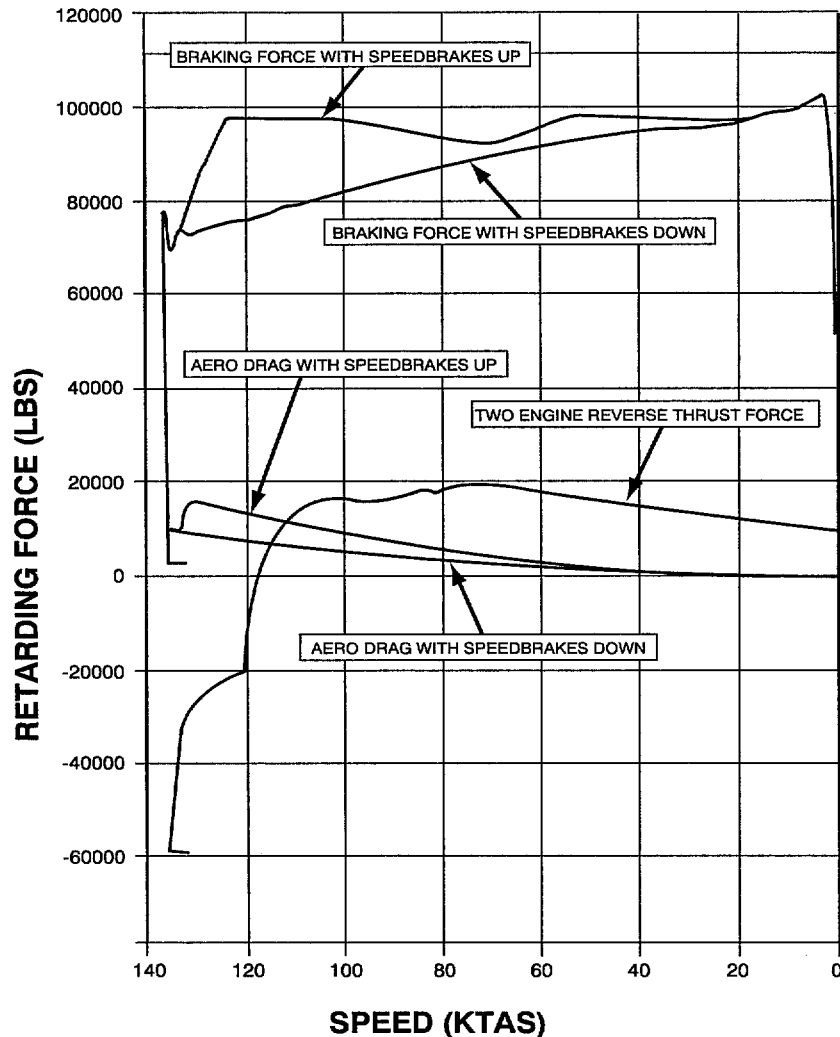

Figure 19
Summary of forces
during a typical
mid-size two-
engine airplane
RTO

2.3.5.3.8 Carbon and Steel Brakes Differences

Recent emphasis on the apparent tendency for carbon brakes to wear out in proportion to the total number of brake applications, as opposed to steel brakes which wear out in proportion to energy absorbed by the brakes, has generated interest in other operational differences between the two types of brakes. While the emphasis on wear difference is necessary, since the economics of brake maintenance is so significant, for most other operational aspects the two brakes can be considered equivalent.

As far as RTO capability is concerned, the type of brake involved does not matter since each brake installation is certified to its particular takeoff energy capability. This means that

either carbon or steel brakes, even fully worn, will be able to perform the maximum certified RTO condition applicable to that installation in a satisfactory manner.

One difference between steel and carbon brakes that is often claimed is an increased tolerance to thermal overload. To understand this in proper perspective, recognize that although the friction elements in a carbon brake (rotating and stationary disks) are made of carbon material, which has good strength and friction characteristics at high temperatures, the brake structure, brake hydraulics, the wheel, and the tire are essentially the same as used for an equivalent steel brake. Within the limitations represented by this non-carbon equipment then, an overheated carbon brake will continue to function reasonably well in situations

where an equivalent steel brake with its metallic disks might not. An overload condition could be caused by excessive taxi braking, riding the brakes, or inappropriate turnaround procedures after landing. In this type of situation, carbon brakes will generally demonstrate better friction characteristics and therefore develop more torque and stopping force than equivalent steel brakes.

The difficulty with this carbon brake thermal advantage is that it is nearly impossible to judge the extra amount of braking that could be done before affecting the ability of the non-carbon components to perform in an RTO situation. This is because the thermal effects on the limiting hardware are so highly time and ambient condition dependent. For instance, whether an airplane has carbon brakes or steel brakes will not matter if enough time has elapsed after a heavy brake application such that the wheel fuse plugs release before the airplane can complete the next takeoff or a subsequent RTO attempt. Pilots should concentrate on proper braking procedures rather than attempt to capitalize on any extra carbon brake advantage. Attention to the brake cooling chart recommendations will avoid these thermal problems and ensure that the airplane stopping performance can be achieved regardless of whether steel or carbon brakes are installed.

The increased thermal overload capability of carbon brakes is closely related to the idea that carbon brakes do not "fade". In other words, they always produce the same torque throughout the stop even as the brake temperature increases. Although many carbon brakes do develop nearly constant torque, some fade considerably in certain conditions. On

the other hand, some steel brakes do not fade very much at all, depending to a large extent on the degree of conservatism built into the brake. In either case, brake fade is taken into account in the AFM performance, for the specific brake installed on each particular airplane. Therefore, brake fade does not need to be an operational concern to the flight crew.

A second factor with steel brakes is the potential loss of structural strength of the rotors and stators at the extreme operating temperatures associated with limiting energy values. This could cause a structural failure of one or more brake stators near the end of the stop. In this case the brake will continue to function but with reduced torque capability. The remaining components, which are common to carbon and steel brakes, are less likely to be affected.

An RTO from at or near the brake energy limits can also mean that after stopping on the runway, the brakes may not be capable of stopping the airplane again, even from low taxi speeds. This is especially true for steel brakes due to the increased chance of structural failure. Therefore, it is important that the crew consider the probable condition of the airplane wheels, brakes, and tires after completing a high speed RTO before attempting to move the airplane from the runway.

One other difference between carbon and steel brakes that might be evident in certain RTO's is brake welding. Steel brakes, which usually have rotors of steel and stators of a copper-iron mix (with a number of special ingredients) can weld together, preventing further wheel rotation. This can even happen before the airplane comes to a full stop, particularly in the last several knots where the antiskid system is not effective.

2.3.5.3.9 High Brake Energy RTO's

Brake rotor and stator temperatures associated with RTO's which involve brake energies at or near certified maximum values, reach approximately 2000 °F for steel brakes, and 2500 °F for most carbon brakes. These high temperatures may, in some situations, ignite certain items in the wheel, tire, and brake assembly. While considerable design effort is made to preclude fires whenever possible, the regulations recognize the rarity of such high energy situations and allow brake fires after a maximum energy condition, provided that any fires that may occur are confined to the wheels, tires and brakes, and which would not result in progressive engulfment of the remaining airplane during the time of passenger and crew evacuation. It is important then, for flight crews to understand the nature of possible fires and the airplane takeoff parameters that could involve these very high brake energies.

There are two primary combustibles in the assembly, namely the tire, and brake grease. Brake hydraulic fluid will also burn if there is a hydraulic leak directed at a very hot brake disk. Tire fires can occur if the rubber compound temperature exceeds approximately 650

°F. Tire fires usually burn fairly slowly for the first several minutes when started by brake heat. Grease fires are even less active, typically involving a small, unsteady, flickering flame, sometimes with considerable smoke. The probability of a crew experiencing a brake fire at the conclusion of an RTO is very low, considering brake design factors, the dispatch parameters, and service history.

In terms of practical guidelines for flight crews, takeoffs at or near V_{MBE} , are normally encountered at high altitude airports or at very hot temperatures. An RTO from close to V_1 speed under these conditions, will require the brakes to absorb a significant amount of energy during the stop. Flight crews can use the Brake Cooling Chart of the airplane operating manual to determine brake energy values if the situation warrants such a review. In cases where an extremely high brake energy might be encountered, the possibility of a brake fire should therefore be considered by the flight crew during the pre-takeoff briefing. If a high speed RTO is subsequently performed the tower should immediately be advised that the airplane is still on the runway, that a high brake energy stop was made, and that emergency equipment is requested to observe the tires and brakes for possible fires.

2.3.5.4 Reverse Thrust Effects

Most of the takeoffs planned in the world do not include reverse thrust credit. This is because the rejected takeoff certification testing under FAA rules does not include the use of reverse thrust. An additional stopping margin is produced by using maximum reverse thrust. We stress the word "maximum" in relation to the use of reverse thrust because of another commonly held misconception. Some pilots are of the opinion that idle reverse is "equally or even more" effective than full or maximum reverse thrust for today's high bypass ratio engines. This is simply not true. The more EPR or N1 that is applied in reverse, the more stopping force the reverse thrust generates. The data shown in Figure 20 is typical for all high bypass engines.

On wet or slippery runways, the wheel brakes are not capable of generating as high a retarding force as they are on a dry surface. Therefore, the retarding force of the reversers generates a larger percentage of the total airplane deceleration.

2.3.5.5 Runway Parameters

Runway characteristics which affect takeoff performance include length, slope, clearway and/or stopway. The effect of runway length is straightforward, however, slope, clearway, and stopway deserve some discussion.

A single value of runway slope is typically chosen by the operator to perform takeoff analysis calculations. This single value is usu-

Figure 20
Effect of engine
RPM and airspeed
on reverse thrust of
a typical high
bypass engine

Net reverse thrust
for a typical
20,000 lb thrust
engine
(lbs per engine)

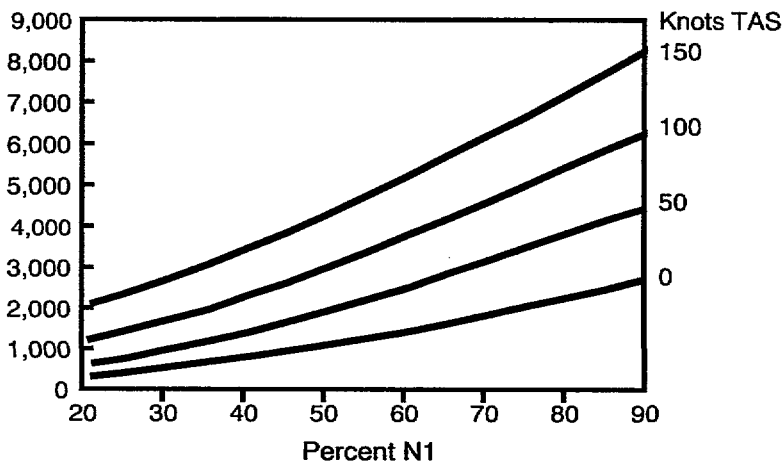

ally taken from information published by the navigation chart services or the airport authorities. On closer inspection however, many runways are seen to have distinct differences in slope along the length of the runway. The single published value may have been determined by a variety of methods, ranging from a simple mathematical average of the threshold elevations, to some weighted average methods proposed by ICAO in an advisory publication⁵.

As a simple example, consider a runway which has only one slope discontinuity. The first two-thirds of the runway has an uphill slope of +2% and the last third has a downhill slope of -2%. The equivalent single slope for this runway, as determined from the ICAO Circular methods, could vary from +1.3% to -0.3%. When the takeoff analysis is made for this runway, the limit weights will be the same as would be determined for an actual single slope runway. However, as the airplane commences a takeoff on the 2% upslope runway, it will accelerate more slowly than it would on any of the equivalent single slope runways, which will result in its achieving V_1 speed further along the runway than was planned. If no event occurs which would precipitate an RTO, the final acceleration to V_R and liftoff will be higher than planned and the overall performance will probably come out close to what was scheduled.

On the other hand, if an event worthy of an RTO should occur just prior to the airplane reaching V_1 , most, if not all of the stop maneuver will have to be carried out on a 2% downhill slope surface instead of the equivalent single slope value, and the RTO will have been initiated with less runway remaining than was assumed in determining the limit weight for that takeoff. There is little the crew

can do in this type of situation, other than in the vein of situational awareness, emphasize in their briefing that an RTO near V_1 for anything other than a catastrophic event is not advisable.

A clearway is an area at least 500 feet wide centered about the extended centerline of the runway with a slope equal to or less than 1.25%. This area is called the clearway plane. No obstructions, except threshold lights, can protrude above this clearway plane. The acceleration to V_2 and 35 feet is completed over the clearway, the use of clearway to increase takeoff weight "unbalances the runway" and results in a lower V_1 speed. The maximum clearway used to calculate takeoff performance is restricted by the regulations to one-half the demonstrated distance from lift-off to 35 ft.

A stopway is an area at least as wide as the runway and centered about the extended centerline. It must be capable of supporting the weight of the airplane without causing damage. Use of stopway also "unbalances the runway" resulting in a higher takeoff weight and increased V_1 speed. An RTO initiated at this V_1 will come to a stop on the stopway. For the sake of completeness, it should be pointed out that not all stopways will qualify as clearways, nor will a clearway necessarily qualify as a stopway. The specified criteria for each must be met independently before it can be used for takeoff performance calculations.

The use of clearway and/or stopway does not necessarily offer any additional margin for RTO stopping. In both cases, the takeoff performance is "unbalanced" by adjusting V_1 speed to plan that the stop will be completed by the end of the paved surface.

⁵ICAO Circular 91-AN/75, *The Effect of Variable Runway Slopes on Take-Off Runway Lengths for Transport Aeroplanes*, dated 1968.

2.3.5.6 (Not Used)

2.3.5.7 Takeoff's Using Reduced Thrust

There are two methods of performing a reduced thrust takeoff. The first is to use a fixed derate of the engine to a lower thrust rating. For example, a JT9D-7F engine operated at a JT9D-7 rating, or a CFM56-3C-1 engine operated at 20,000 lbs of thrust (-B1 rating) instead of the full 23,500 lb rating. When a fixed derate is used, the engine EGT and RPM limits are reduced and the crew are not to exceed the reduced limits in normal operation. As a result of the lower limit thrust with a fixed derate, the minimum control speeds V_{mcg} and V_{mca} are also reduced. Since the choice of derate thrust levels is usually restricted to one or two preselected values, it is rare that the takeoff performance at the derated thrust would be reduced to field length limit levels.

The second way of reducing takeoff thrust is to use the Assumed Temperature Method. The fundamental difference between fixed derates and the Assumed Temperature Method is that the operating limits of the engine are not reduced when using Assumed Temperature Method reduced thrust. The flight crew may increase the thrust to the full engine rating at any time during the takeoff if it is deemed appropriate. For instance, British CAA Flight Manuals include a recommendation to increase thrust on the operating engines to the full

rating in the event that an engine fails during the takeoff. As a result, the V_{mcg} and V_{mca} speeds are not reduced below the full rating values when using the Assumed Temperature Method.

Fixed derates and the Assumed Temperature Method also differ in terms of the performance margins that are inherent to their use. As was previously mentioned, at limit weights, a takeoff performed using a fixed derate takeoff thrust will conform to the minimum performance levels of the regulations, just as a limit weight takeoff would when using full rated takeoff thrust. The associated V_1 speed provides the standard certification "margins" of a 35 foot screen height or a stop at the end of the runway in the event of an engine failure.

When using the Assumed Temperature Method, additional "margins" are created in both the "Go" and "Stop" cases. As the name implies, the technique used to calculate the performance with the Assumed Temperature Method is to assume that the temperature is higher than it actually is, and to calculate takeoff thrust and speeds at the higher temperature.

The primary reason that the use of the Assumed Temperature Method results in performance margins is that the true airspeed of the airplane is lower than would be the case if the actual temperature were equal to the assumed temperature.

2.3.5.8 The Takeoff Data the Pilot Sees

The typical takeoff data table (sometimes referred to as runway analysis or gross weight tables) shows the limit takeoff weight for a specific runway over a range of ambient temperatures. There may also be corrections for wind, pressure altitude, bleed configurations, and runway surface conditions. Each table usually shows the limit weights for only one flap setting. Some airlines show the takeoff speeds and the takeoff thrust EPR or N_1 setting along with the limit weights. The tables can display limit weights for Field Length, Climb, Obstacle Clearance, Tire Speed and Brake Energy, and tell which factor is limiting for each wind and temperature. This tabular display of the takeoff data has become the standard tool for using the assumed temperature method to reduce the takeoff power setting and thereby improve engine life.

This takeoff data is some of the most important data used on any flight. It is essential that flight crews know their actual takeoff weight and that they use the proper takeoff speeds. It is equally important that the flight crew be aware of their proximity to the limit weights for that takeoff's ambient conditions. These limit weights and speeds are more than just numbers. They represent the maximum certified takeoff performance of the airplane. If the actual takeoff weight is equal to or near the runway limit weight, the crew should note that fact and be extra alert that a reject from near or at V_1 will require prompt application of the full stopping capability of the airplane to assure stopping on the runway.

If the actual airplane weight is less than the limit weight, the crew should treat the normally obtained V_1 speed as a "limit speed" unless their operations department has provided them with a specific method of unbalancing the V_1 speed to utilize the excess runway available. The operator should assure that a suitable, non-ambiguous method of presenting the V_1 speed is chosen, whether it is a balanced or unbalanced speed.

2.3.6 Increasing the RTO Safety Margins

There are a number of choices and techniques the crew can make and practice that will increase the RTO margins for takeoff. Some involve airline policy and require the publication of additional data (such as multiple flap setting takeoff weight and speed data) and some are just good personal technique.

2.3.6.1 Runway Surface Condition

The crew cannot control the weather like they can the airplane's configuration or thrust. Therefore, to maximize both the "Go" and "Stop" margins, they must rely on judiciously applying their company's wet or contaminated runway policies as well as their own understanding of how the performance of their airplane may be affected by a particular runway surface condition.

2.3.6.2 Flap Selection

Figure 21
Typical Large
Two-Engine Jet
transport Takeoff
Performance

8,700 FT RUNWAY SEA LEVEL 37° C	FLAP SETTING			
	1	5	15	20
Runway limit weight, lb (kg)	358,300 (162,494)	374,200 (169,705)	389,000 (176,417)	393,600 (178,503)
Climb/Obstacle limit weight, lb(kg)	414,100 (187,800)	407,300 (184,717)	393,600 (178,503)	383,000 (173,696)

Often the RTO safety margin can be increased by selection of an alternative takeoff flap setting. Consider for example, the effect of takeoff flap selection on the performance limit weights of a typical large two-engine airplane, as shown in Figure 21.

If a flight requires the absolute maximum takeoff weight, the above weight limits would dictate choosing Flaps 15 since 389,000 pounds is the highest weight allowed. Flaps 20 is Climb/Obstacle limited to a lower weight and Flaps 1 and 5 are Runway limited to lower weights. If the actual takeoff weight desired is equal to the maximum limit weight, there is no flap selection option. The takeoff will need to use Flaps 15.

More typical, however, the airplane's actual takeoff weight is well below the maximum. There are then two viable ways to improve RTO stopping distance margin: either by flap selection or by reduced V_1 techniques.

If the flight's actual takeoff weight was 374,200 pounds, investigating the above table indicates Flaps 5, Flaps 15, or Flaps 20 are all acceptable. Flaps 5 is runway limited so it offers no additional RTO margin. However, Flaps 15 and Flaps 20 both offer an opportunity for additional stopping distance margin. These additional stopping margins have been calculated for the above example and are shown in Figure 22.

Thus, if there are no other constraints such as obstacles or critical noise abatement procedures that would prevent the selection of a greater flap setting, the crew could give themselves 1000 feet of extra stopping distance in case an RTO was required on this takeoff.

Remember that there are some disadvantages to selecting a higher flap setting. These disadvantages include diminished climb performance and slightly more fuel consumed due to the higher drag configuration and the additional flap retraction cleanup time that will be required.

Figure 22
Effect of Flap
selection on RTO
stopping margins

FLAP SETTING	5	15	20
STOPPING MARGIN	ZERO	850 FT	1000 FT

2.3.6.3 Runway Lineup

Positioning the aircraft on the runway in preparation for takeoff is an important element in maximizing the amount of pavement available for a possible to RTO maneuver. Correction to the available runway length can be made to the takeoff analysis on those runways where it is not possible to position the airplane at the beginning of the published distance.

Correct runway lineup technique should always be practiced regardless of whether or not there is excess runway available. Even if an allowance has been made, it is up to the crew operating the flight to align the airplane on the runway using the shortest possible distance than taken into account by their company, then there is that much extra margin for the takeoff.

2.3.6.4 Setting Takeoff Thrust

At takeoff thrust settings, gas turbine (jet) engines operate at very high RPM. It typically takes several seconds for the engines to spool up from a low idle or taxi thrust to takeoff power after the thrust levers are advanced. During this time, the aircraft is not accelerating at full potential because the engines are not yet developing full power.

The demonstrated takeoff distance is achieved when the takeoff thrust is set prior to releasing the brakes, but this technique is often not practical in line operations due to expedited takeoff clearances, engine FOD hazards, and passenger comfort. As a result, most takeoffs are performed as “rolling takeoffs”, with the

thrust being set as the airplane begins the takeoff roll. However, this technique must be accomplished promptly to avoid compromising the takeoff performance. A delayed application of takeoff thrust will increase the time and distance to reach V_1 speed, consequently, less runway will be left to stop the airplane should an RTO be necessary. The thrust should be set promptly, according to the airframe manufacturer’s recommendations. The non-flying pilot or flight engineer then typically makes any final adjustments and monitors the engines for any abnormalities.

On airplanes equipped with autothrottles, an additional item to be aware of is that some autothrottle systems incorporate “Thrust Hold” features which will stop advancing the thrust levers after the airplane reaches a pre-determined threshold airspeed value. A delay in engaging the autothrottle can result in the thrust stabilizing below the takeoff target setting and the initial acceleration being less than required.

The engine instruments should be monitored closely for any abnormal indications. Past RTO accidents have occurred after an engine problem was identified early in the takeoff roll, but no action was initiated until the airplane had reached or exceeded V_1 .

Company operations manuals or training manuals contain correct procedures for setting takeoff thrust. Observing these procedures assures efficient engine acceleration and, as a consequence, proper aircraft acceleration throughout the entire takeoff roll.

2.3.6.5 Manual Braking Techniques

Modulation of brake pressure or “pumping the brakes” was the way most people were taught to apply automobile brakes when braking conditions were less than favorable. This prevented sustained skids and therefore afforded both better braking and directional control. Both benefits occur because a skidding tire produces less frictional force than a tire which continues to rotate. Flight deck observation and simulator testing, however, both indicate that this technique has at times been carried over into the cockpit of jet transports. With the antiskid control systems in jet transport airplanes this technique is not only unnecessary, it results in degraded stopping capability and therefore excessive stopping distance especially for adverse runway conditions. **Proper braking technique in an RTO is to apply full brake pedal force (“stand on it”) and maintain full brake pedal force until the airplane comes to a complete stop.**

The pilot’s foot position relative to the rudder pedal can also have an effect on the achievement of full brake pressure. It was noted during a study conducted by the Training Aid Working Group⁶ that foot position during the takeoff roll tends to be an individual preference. Some pilots prefer to have their feet “up on the pedals” to be ready to apply full brakes if required. Pilots who prefer this technique also noted that their toes are “curled back” to avoid unwanted brake applications when applying rudder. The other technique is to rest the heels on the floor during the takeoff roll, and then raise them to be on the pedal to apply full braking. No problems were noted with either technique.

One technique which did not work well was also noted. It is not possible to apply maximum brake pedal deflection, and hence full brake pressure, if the heel of the foot is left on the floor unless the pilot has very big feet. In an

RTO stop maneuver, the feet should be up on the rudder pedals and steady, heavy pressure applied until the airplane is completely stopped. Pilots should develop a habit of adjusting their seat and the rudder pedals prior to leaving the gate. The ability to apply maximum brake pedal force as well as full rudder should be checked by both pilots.

The importance of maintaining maximum braking and full reverse thrust during an RTO until the airplane “rocks to a stop” cannot be overstressed. During a reject from V_1 , the goal is safety, not passenger comfort. The amount of distance required to decelerate from a given speed at the high weights associated with takeoff is significantly greater than from the same speed at a typical landing weight. If the pilot tries to judge the amount of runway remaining against the current speed of the airplane, the visual perception that the airplane will stop on the runway (“we’ve got it made”), will prompt a decrease in the stopping effort. It is precisely at this point in the RTO that the difference between a successful Go/No Go decision and an accident can occur. The brakes may be nearing their energy absorption limits and the airplane may be entering a portion of the runway contaminated with rubber deposits, which can be very slick if wet. In several of the RTO accidents and incidents of the past, there was excess runway available to complete the stop, but the premature relaxation of the stopping effort contributed to an overrun.

An additional consideration in completing a successful RTO is that the crew should assess the condition of the airplane after it comes to a stop. If there is evidence of a fire or other significant hazard to the passengers, an evacuation on the runway is definitely preferable to “clearing the active.” Every second counts in an actual emergency evacuation. In at least one RTO accident, many of the fatalities were caused by delaying the evacuation until the aircraft was clear of the runway.

⁶The Training Aid Working Group is the industry and regulatory team that developed the Takeoff Safety Training Aid

2.3.6.6 Antiskid Inoperative Braking Techniques

Antiskid inoperative dispatches represent a special case for brake application techniques. In this situation the pilot executing the RTO should apply steady moderate pedal pressure consistent, in his judgement, with runway conditions, airplane dispatch weight and the available runway length. Full brake pressure should not be applied with the antiskid system inoperative due to the risk of tire failure. To minimize the possibility of skidding a tire, which can lead to a blowout, the speedbrakes should be deployed before brakes are applied. This provides the highest possible wheel loads to keep the wheels rotating with the forward motion of the airplane.

2.3.6.7 RTO Autobrakes

Autobrake system functions and crew actions to initiate these functions vary from one airplane model to another. For example, some systems include automatic spoiler extension, others do not. Therefore, training in use of the system must be tailored to the particular system installed. The following discussion illustrates the general intent of autobrake systems.

Brake application is an immediate pilot action when initiating an RTO, and this application should be of maximum effort. An automatic brake application system called "RTO AUTOBRAKES" is being installed on more and more airplanes today to insure that this critical step is performed as rapidly as possible when an RTO is initiated. This system is designed to automatically apply maximum brake pressure if during the takeoff roll, all of the thrust levers are retarded to idle, and the aircraft speed is above a specified value (usually 85-90 knots). RTO Autobrakes, therefore, achieve the same airplane stopping performance as a proper, manual application of full foot pedal braking. No time delays are built in to the RTO autobrakes such as are used in some landing autobrake settings.

The use of "RTO AUTOBRAKES" eliminates any delay in brake application and assures that maximum effort braking is applied promptly. Possible application delays arising from distractions due to directional control requirements in crosswinds, or application of less than maximum brake force, are completely eliminated. The results of a simulator study conducted by the Training Aid Working Group also suggest that, on the average, those RTO's performed with RTO autobrakes ARMED resulted in more runway distance remaining after the stop than did the RTO's performed using manual braking only. This result is more significant because few pilots left the autobrakes engaged for more than a few seconds before overriding them and applying full manual braking. The difference in stopping performance is attributed to the first few seconds of high deceleration with the autobrakes at full pressure.

When the RTO autobrakes are ARMED for takeoff, the pilot not flying must monitor the system and advise the pilot flying if a DISARM condition occurs. The pilot flying should also monitor the deceleration of the airplane for acceptability and be prepared to apply manual braking if required or, the pilot performing the reject procedure should apply maximum manual braking during the RTO. In this latter case arming the RTO autobrake function only serves as a backup if for some reason manual braking is not applied.

The brake pedal forces required to disarm the autobrakes may vary significantly between the landing autobrake settings and the RTO autobrake setting of any given airplane, between one airplane model and another of the same manufacturer, as well as between the various manufacturers' airplanes. It is not surprising that this point is not fully understood in the pilot community. It is important that pilots be made aware of how the details of any particular airplane's autobrake system might affect RTO performance and that they obtain the necessary information from their training department.

2.3.6.8 (Not Used)

2.3.6.9 The V_1 Call

One important factor in avoiding RTO overrun accidents is for the crew to recognize reaching V_1 when the airplane does, in fact, reach V_1 — not after. The airplane's stopping performance cannot match that specified in the Airplane Flight Manual if the assumptions used to derive that performance are violated — knowingly or inadvertently. Operationally, careful attention to procedures and teamwork are required to match the human performance recognized by the AFM.

Basic operating procedures call for the pilot flying the airplane to include airspeed in his instrument scan during the takeoff ground roll. Hence he is always aware of the approximate speed. The pilot not flying monitors airspeed in more detail and calls-out "Vee-One" as a confirmation of reaching this critical point in the acceleration.

The pilot flying cannot react properly to V_1 unless the V_1 call is made in a timely, crisp, and audible manner. One method of accomplishing this by a major U.S. carrier is their adoption of a policy of "completing the V_1 callout by the time the airplane reaches V_1 ." This is an excellent example of the way airlines are implementing procedures to improve RTO safety. It is a good procedure and it should preclude a situation where the "No Go" decision is inadvertently made after V_1 . However, the success of such a policy in reducing RTO's after V_1 , without unduly compromising the continued takeoff safety margins, hinges on the line pilot's understanding of the specific airplane model's performance limitations and capabilities.

Another proposal for calling V_1 is to use a call such as "Approaching V_1 " with the V_1 portion occurring as the airspeed reaches V_1 . Either of these proposals accomplish the task of advising the flying pilot that the airplane is close to the speed where an RTO for all but the most serious failures is not recommended.

A frequently cited factor in RTO accidents that occurred when the First Officer was flying, is the lack of any airspeed calls by the Captain during the takeoff. This type of poor crew coordination may be overcome in future airplane designs by the use of automated " V_1 "

and "Engine Failure" calls which will eliminate much of the variability experienced in today's operations. Even with an automated call system however, an "Approaching" call by the non-flying pilot would still seem to be an appropriate method of ensuring airspeed situational awareness for both pilots.

2.3.6.10 Crew Preparedness

Important crew factors directly related to eliminating RTO overrun accidents and incidents are:

- Brief those physical conditions which might affect an RTO that are unique to each specific takeoff.
- Both pilots must be sure to position the seat and rudder pedals so that maximum brake pressure can be applied.
- Both pilots should maintain situational awareness of the proximity to V_1 .
- Use standard callouts during the takeoff.
- Transition quickly to stopping configuration.
- Don't change your mind. If you have begun an RTO, stop. If you have reached V_1 , go, unless the pilot has reason to conclude that the airplane is unsafe or unable to fly.
- Use maximum effort brake application.
- Assure deployment of speedbrakes.
- Use maximum reverse thrust allowable.

The accident records frequently show that slow or incomplete crew action was the cause of, or contributed to, an RTO overrun event. The crew must be prepared to make the Go/No Go decision on every takeoff. If a "No Go" decision is made, the crew must quickly use all of the stopping capability available. Too often, the records show uncertainty in the decision process and a lack of completeness in the procedures. Be ready to decide and be ready to act.

2.4 Crew Resource Management

Crew Resource Management (CRM) is a term that can mean many things. In this context it is simply intended to encompass the factors associated with having the crew members work effectively together to make optimal Go /No Go decisions and effectively accomplish related procedures. It is recognized that the content of a CRM discussion on Go/No Go decisions must reflect the needs and culture of each individual operator. Therefore, the material contained in this section is provided only as an example of the type of CRM information which could be provided to the line pilot.

2.4.1 CRM and the RTO

Effective CRM can improve crew performance and in particular, decision making during takeoff. Often, Go/No Go decisions must be made "instantaneously" and as a result, the significance of CRM is not readily apparent. However, the fact that a critical decision must be made and implemented using rapidly changing, often incomplete information in a dynamic environment in which the time available decreases as the criticality of the decision increases, is reason for effective CRM. Some aspects of CRM are especially important with respect to the Go/No Go decision.

2.4.2 The Takeoff Briefing

Crew members must know what is expected of them and from others. For optimum crew effectiveness, they should share a common perception - - a mental image - - of what is happening and what is planned. This common perception involves a number of CRM areas: communications, situational awareness, workload distribution, cross-checking and monitoring.

A variety of means are used to achieve this common perception. This begins with airline standard operating policies (SOP's) that clearly define captain and first officer as well as pilot flying and pilot not flying responsibilities and duties. Training reinforces the crew's knowledge and skill, while standardization insures acceptable, consistent performance, across all fleets and cultures within an airline.

A takeoff briefing is another means of improving the crew's awareness, knowledge, and team effectiveness; especially when special circumstances or conditions exist. The briefing is not necessarily a one-way process. In fact, asking for clarification or confirmation is an excellent way to insure mutual understanding when required. A simple, "standard procedures" takeoff briefing might be improved by adding, "I'm not perfect, so back me up on the speedbrakes and my use of the RTO autobrakes" or, "if we're not sure of an engine failure 5 knots before V_1 , we'll continue the takeoff and I'll state 'CONTINUE TAKEOFF'". These briefings can improve team effectiveness and understanding of the Go/No Go decision planning and communications to be used. Such additions might be especially appropriate on the first segment of a flight with a relatively new first officer or a crew's first flight of the month.

A review of actions for a blown tire, high speed configuration warning, or transfer of control are examples of what might be appropriate for before takeoff (or before engine start) review. Such a briefing should address items that could affect this takeoff, such as runway contamination, hazardous terrain or special departure procedures. The briefing should not be a meaningless repetition of known facts, but rather a tool for improving team performance, that addresses the specific factors appropriate to that takeoff.

2.4.3 Callouts

Meaningful communication, however brief, regarding a non-normal situation during takeoff and RTO can often mean the difference between success and disaster. For this reason, communications must be precise, effective, and efficient. Standard callouts contribute to improved situational awareness. These callouts, coupled with all crewmembers being aware of airspeed, maximize the opportunity for a common understanding of what actions are proper in the event of a non-normal situation. The crewmember noting a problem should communicate clearly and precisely without inferring things that may not be true. For example, the loss of fuel flow indication alone does not necessarily mean an engine failure. Use of standard terms and phraseology to describe the situation is essential. The pilot tasked to make the RTO decision should clearly announce this decision, whether it be to continue or reject.

2.4.4 The Use of All Crew Members

It's important to understand that all crewmembers on the flight deck play an important role in the Go/No Go decision and RTO maneuver. Company policies shape these roles, however, how the team is organized for each takeoff can make a difference in team performance. Knowing your own capabilities and that of the other crewmembers is part of situational awareness and should be used in planning for a given takeoff. Although it's "the first officer's leg", it might not be an effective plan to task an inexperienced first officer with a marginal weather takeoff when weight is also limited by field length. Consider the possibility of an RTO when assigning takeoff duties.

2.4.5 Summary

Each airline approaches CRM in a slightly different manner, but the goal of effective teamwork remains the same. This material is an example of the type of CRM information that could be used to promote a common perception of RTO problems and actions.

3

Example Takeoff Safety Training Program

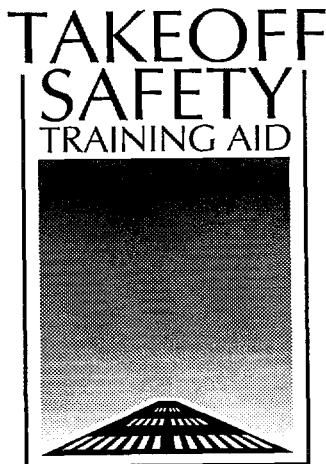

(This page intentionally left blank)

Example Takeoff Safety Training Program

Table of Contents

3

Section	Page
3.0	Introduction 3.1
3.1	Academic Training Program 3.2
3.1.1	Training Objectives 3.2
3.1.2	Academic Training Program Modules 3.2
3.1.3	Academic Training Syllabus 3.2
3.1.4	Additional Academic Training Resources 3.3
3.2	Simulator Training Program 3.3
3.2.1	Training Objectives 3.3
3.2.2	Simulator Training Syllabus 3.4
3.2.3	Pilot Simulator Briefing 3.6
3.2.4	Simulator Exercises 3.6
3.2.4.1	Exercise 1, Initial Introduction to RTO's 3.7
3.2.4.2	Exercise 2, RTO with engine failure 5 knots prior to V_1 , Manual Braking 3.8
3.2.4.3	Exercise 3, RTO with engine failure 5 knots prior to V_1 , Autobrakes 3.9
3.2.4.4	Exercise 4, RTO with engine failure 5 knots prior to V_1 , Wet runway with no corrections to weight or V_1 3.10
3.2.4.5	Exercise 5, RTO with engine failure 5 knots prior to V_1 , Wet runway with wet runway corrections 3.11
3.2.4.6	Exercise 6, Takeoff continued with engine failure 5 knots prior to V_1 3.12
3.2.4.7	Exercise 7, Blown tire at V_1 -10 knots 3.13
3.2.4.8	Exercise 8, Indicator failure/cockpit alert or advisory light at V_1 -10 knots 3.14
3.2.5	Exercises With Other Models 3.14
3.3	Simulator Implementation Guide 3.15
3.3.1	Simulator Fidelity Checks 3.15
3.3.2	Tuning for Accomplishments of Objectives 3.15
3.3.3	Grooved Runways 3.15
Appendix 3-A Instructor Pilot Syllabus Briefing Supplement	
Appendix 3-B Pilot Guide to Takeoff Safety Questions	
Appendix 3-C Takeoff Safety Briefing	
Appendix 3-D Simulator Exercises	
Appendix 3-E Takeoff Safety Video Script, <i>Rejected Takeoff and the Go/No Go Decision</i>	

(This page intentionally left blank)

Example Takeoff Safety Training Program

3.0 Introduction

The overall goal of the *Takeoff Safety Training Aid* is to reduce the number of RTO related accidents and incidents by improving the pilot's decision making and associated procedure accomplishment through appropriate education and training. The example training program illustrates the type of training that should be conducted to meet that goal. This program is primarily directed at improving the pilot's decision-making capability by increased understanding of the takeoff decision situation, and the pilot's performance in RTO situations through practical experience.

Although structured to stand alone, the example Takeoff Safety Training Program can be integrated with existing initial, transition, and recurrent/refresher training and checking programs. The training program is designed to facilitate flight crews in reaching and maintaining proficiency in:

- Recognizing and understanding situations and factors that make high speed RTO decisions critical.
- Making appropriate Go/No Go decisions.
- Executing RTO procedures and employing techniques that maximize the stopping capability of the airplane, should a high speed RTO be necessary.
- Continuing the takeoff safely, should that be deemed the most appropriate action.

An Academic Training Program (Section 3.1), and a Simulator Training Program (Section

3.2) provide the opportunity to attain this required knowledge and skill. A Simulator Implementation Guide (Section 3.3) is provided to complete the Takeoff Safety Program. These sections are described as follows:

Section 3.1, the Academic Training Program consists of a description and suggested method for applying the academic training portions of the *Takeoff Safety Training Aid*. For those pilots who are not provided simulator training, this section will provide a comprehensive review of Go/No Go concepts. For those pilots who undergo simulator training, this section will prepare them for the decision making and critical RTO performance they will experience in the simulator.

Section 3.2, the Simulator Training Program consists of a pre-simulator briefing outline and a set of example simulator exercises. These exercises are designed to practice the RTO procedure and to demonstrate to the crew the particular stopping and going characteristics of their airplane in critical situations. Decision making is also practiced.

Section 3.3, the Simulator Implementation Guide is provided to assist in incorporating the takeoff situations chosen from the simulator training program. The simulator implementation guide provides guidance to develop a simulator program that accurately reflects the airplane's RTO performance.

The example Takeoff Safety Training Program utilizes the B737-300 with CFM56-3B-2 engines to discuss and demonstrate potential RTO situations. However, the program can be adapted to any airplane type using the information provided by the manufacturer and can be stored in Appendix 3-D.

3.1 Academic Training Program

The Academic Training Program focuses on the elements that are important to good RTO decision making and good RTO execution.

3.1.1 Training Objectives

The objectives of the Academic Training Program are to provide the pilot with the knowledge to:

- Be able to recognize and understand the situations and factors that make high speed RTO's hazardous.
- Understand the dynamics of making the Go/No Go decision and performing the associated maneuver.

A suggested syllabus is provided with the knowledge that no single training format or curriculum is best for all operators or training situations. All of the training materials have been designed to "stand alone." As a result, some redundancy of the subject material occurs. However, using these materials together in the suggested sequence will enhance overall training effectiveness.

3.1.2 Academic Training Program Modules

The following academic training modules are available to prepare an academic training curriculum:

Pilot Guide - The Pilot Guide to Takeoff Safety (*Takeoff Safety Training Aid*, Section 2.0) is a comprehensive treatment of the rejected takeoff and lessons learned from past RTO accidents and incidents. The Pilot Guide is designed as a document that may be reviewed by an individual pilot at any time prior to formal RTO academic or simulator training.

Pilot Guide Questions - A set of questions based on the material contained in the Pilot Guide is contained in Appendix 3-B. These questions are designed to test the pilot's knowledge of each section of the Pilot Guide. In a takeoff safety training curriculum these questions may be utilized in one of two ways:

- 1) As part of a pilot's review of the Pilot Guide.
- 2) As an evaluation to determine the effectiveness of the pilot's self study prior to subsequent academic or simulator training for RTO's.

Takeoff Safety Briefing - A paper copy of view foils with descriptive words for each one that can be used for a classroom presentation is contained in Appendix 3-C. The briefing supports a classroom discussion of the Pilot Guide.

Video (optional) - *Rejected Takeoffs and the Go/No Go Decision* - This video presents the RTO problem and suggests two areas of concern, namely that pilots may perform rejects unnecessarily and when rejects are performed, they may be performed improperly. It shows the causes of RTO accidents and incidents and illustrates proper stopping techniques. It also discusses reasons to reject and how to handle wheel or tire problems.

3.1.3 Academic Training Syllabus

Combining all of the previous academic training modules into a comprehensive training syllabus results in the following suggested Academic Training Program:

Training Module	Method of Presentation
• Pilot Guide	Self Study/classroom
• Pilot Guide Questions	Self Study/evaluation
• Video (optional) - <i>Rejected Takeoffs and the Go/No Go Decision</i>	Classroom
• Takeoff Safety Briefing	Classroom

3.1.4 Additional Academic Training Resources

The Takeoff Safety Background Data (*Takeoff Safety Training Aid*, Section 4) is an excellent source of background information for an instructor desiring a more detailed explanation of the material contained in the Pilot Guide to Takeoff Safety or the optional video, *Rejected Takeoffs and the Go/No Go Decision*. Additionally, this section contains charts and graphs which could be utilized by an instructor to emphasize specific points.

3.2 Simulator Training Program

The Simulator Training Program addresses the goals of decision making and procedure accomplishment. Training and practice are provided to allow the pilot to experience realistic situations requiring timely decisions and correct procedures to succeed.

To be most effective, the simulator training requires the student pilot to be familiar with the material in the Academic Training Program.

3.2.1 Training Objectives

The objective of the Simulator Training Program is to provide the flight crews with the necessary experience and skills to:

- Recognize those situations requiring a rejected takeoff.
- Recognize those situations where it is better to continue a takeoff.
- Perform a required rejected takeoff in a safe and effective manner.
- Perform a successful takeoff after experiencing a malfunction and making a decision to continue.
- Communicate and coordinate on the flight deck during critical takeoffs.
- Better understand the performance margins in the Airplane Flight Manual.
- Understand the stopping characteristics of the airplane.

3.2.2 Simulator Training Syllabus

The training given during initial, transition and recurrent training should follow a building block approach.

The first time the RTO is introduced it should be well-briefed in terms of the mechanics of the RTO and the order of the items performed. Good crew coordination should be emphasized, particularly when the first officer is making the takeoff. During these training sessions, the procedure should be practiced to proficiency by both crew members. The training should include first officer takeoffs because the crew coordination requirements are different from captain takeoffs.

The rejected takeoff should be covered again after engine-out takeoff proficiency has been attained. The advantages and disadvantages of rejecting versus continuing a takeoff should be presented. Each operator should consider incorporating unique airports/conditions from their route structure into their training program. It is recommended that two planned rejected takeoffs be performed with an engine failure one second (5 knots) before V_1 . One should be done using manual braking and the other should be done using RTO autobrakes (if available) for the entire stop. This should enable the pilots to contrast the two techniques and increase their confidence in the autobrakes. Ideally the airplane should stop just prior to the end of the runway. Assuming the simulator accurately reflects airplane performance, any additional stopping margin observed can be attributed to quick pilot reaction and the effects of reverse thrust. Overruns can be attributed

to delayed brake application, inadequate brake pressure, excessive runway lineup distance, or delayed takeoff thrust setting.

The maneuver should be repeated a third time with a wet runway applying whatever rules the company normally uses. An optional method for airlines who do apply wet runway rules is to do the exercise with and without application of these rules. This should reinforce the impact of wet runways on flight operations.

The final exercise is to fail an engine once again at one second prior to V_1 and prebrief the pilot to continue the takeoff. With appropriate instructor assistance, the non flying pilot should note the radio altimeter height crossing the end of the runway to emphasize the performance that is available under the regulations.

From this lesson on, takeoff malfunctions should be introduced during other simulator lessons to enhance decision making. Items that historically have caused accidents and incidents such as wheel/tire problems, configuration warning, noncritical indicators or lights, or other items of current interest within the airline (such as ATC or crew coordination problems) should be introduced.

The simulator lesson prior to the evaluation should include a representative sample of the types of RTO's given on evaluation flights, again emphasizing good decision making and proper procedure execution.

The content of the evaluation flight is normally dictated by the regulatory agency.

Table 3.2-1 Example Simulator Training Program

Exercise	Exercise Description	Training Objectives
1	Engine Failure at approximately V ₁ -20 knots. Gross weight not limited by runway length.	Demonstrate ground handling characteristics with an engine inoperative.
2	Engine failure V ₁ -5 knots. Prebrief failure, request RTO using manual braking. Gross weight at runway limit.	Demonstrate certified performance limit and illustrate effort required to stop the airplane within the field length.
3	Engine failure at V ₁ -5 knots. Prebrief failure, request RTO using autobrakes. Gross weight at runway limit.	Increase familiarity with stopping performance available. Increase confidence in and appreciation for autobrakes.
4	Engine Failure at V ₁ -5 knots. Use wet runway. Prebrief failure and request RTO be done. Gross weight at runway limit.	Demonstrate that wet runways are not automatically accounted for. Show stopping capability when no correction is made to weight or V ₁ .
5 (optional)	Engine failure at V ₁ -5 knots. Use wet runway. Apply company wet runway rules. Prebrief failure and request RTO be done. Compare stopping performance with previous stops. Gross weight at runway limit.	Increase confidence in wet runway rules. Confirm importance of applying appropriate rules.
6	Engine failure at V ₁ -5 knots. Prebrief failure and request takeoff be continued. Non-flying pilot should note radio altitude passing end of runway. Gross weight at runway limit.	Demonstrate flight manual provided height over end of runway with engine failure. Build confidence in pilot's ability to fly airplane with engine failure and confidence in climb capability available.
7	Blown tire at V ₁ -10 knots. Gross weight at runway limit. (optional) Done during any takeoff with no other specific teaching point.	Familiarize crew with feeling of blown tire. If stop decision is made, illustrates decreased stopping performance.
8	Indicator failure/cockpit alert or advisory light at V ₁ -10 knots. Done during any takeoff with no other specific teaching point.	Reinforce guidance to continue takeoffs in such situations.

3.2.3 Pilot Simulator Briefing

General Briefing:

Pilots should be familiar with the material in the Ground Training Program prior to beginning rejected takeoff training. However, a briefing on the following flight crew actions should be given, specifically as they apply to the simulator training program:

Prior to the first RTO exercise:

Explain that in the "low speed regime" (company defined) a takeoff should be rejected for:

- systems failures
- unusual noise or vibration
- tire failure
- abnormal acceleration
- engine failure/fire
- unsafe takeoff configuration
- unable to fly
- fire warning

In the "high speed regime" (company defined) the takeoff should be rejected for an engine failure/fire or the perception that the aircraft is unsafe or unable to fly.

Review the sequence of events in the RTO procedure. Emphasize the importance of:

- Maintaining directional control
- Brakes: Primary stopping device
- Thrust Levers: Starts autobrakes working
- Speedbrake: Puts weight on wheels for braking, aerodynamic drag
- Reverse Thrust: Not included in the flight manual calculation
- Speed of Procedure: Possible to do procedure faster than the flight manual model

Discuss the captain's takeoff and the procedure to be followed. Discuss the first officer's takeoff and the procedure to be followed. Discuss crew coordination including transfer of control, if appropriate.

Discuss the actions to be taken after the stop including informing the tower, notifying the passengers/flight attendants, performing the non-normal checklist (if required), checking the brake cooling charts and evacuating the airplane (if required). A brake/tire fire can possibly occur following a high energy RTO. The flight crew should request fire fighting equipment as a precautionary measure in such cases.

Prior to the Second Lesson with RTO's:

- Review each maneuver to be performed
- Review benefits of reverse thrust and quick action
- Review wet runway rules/policies
- Review procedure and common errors

3.2.4 Simulator Exercises

The following sections contain detailed descriptions of example simulator training exercises. They illustrate the type of information that should be provided to training departments to do takeoff safety training. These exercises should be modified by operators to fit their particular syllabus and training devices to optimize learning. The General Description section of each exercise explains which of the initial conditions is of particular importance.

These examples are for the B737-300, see Appendix 3-D for example simulator exercises for other aircraft models.

The Basic Simulator Training Syllabus - Instructor Pilot Syllabus Briefing Supplement (Appendix 3-A) provides an example combination of exercises with other material previously referenced to produce such a syllabus. This type of handout can be used by an instructor to conduct the training program shown in Table 3.2-1.

3.2.4.1 Exercise 1, Initial Introduction to RTO 's

General Description

The initial conditions for this exercise should be typical for the airfield and airplane model. None of the initial conditions should be limiting so as not to detract from the primary purpose of developing proficiency in the mechanics of the RTO procedure. The RTO should be prompted by a clear indication of a problem such as an Engine Failure. The speed at which the malfunction occurs should be one that is low enough to ensure that the pilot will reject, yet high enough to enable the crew to get a good "feel" of it. Approximately 20 knots prior to V_1 works well. The exercise is specifically designed to develop proficiency in the mechanics of the RTO procedure for both the captain and first officer. It will also demonstrate ground handling characteristics of an airplane with an engine failed.

Initial Conditions

Runway: KMWH Rwy 32R
Airplane: 737-300 (CFM-56-3B-2 engines)
Airplane Gross Weight: 113,000 pounds/51,300 kgs
Takeoff Flaps: 5
Center of Gravity: 24%
Takeoff Thrust: Max rated
 V_1 : 129 V_R : 131 V_2 : 141 Stabilizer Setting: 4.0
Ceiling and Visibility: Clear
Wind: Calm
Temperature: 68 F/20 C
Runway Condition: Dry
Airport Elevation: 1185 feet
Runway Length: 13,502 feet
QNH: 29.92/1013

Piloting Technique Requirements

The pilot will conduct a normal takeoff. When the malfunction is encountered, the Rejected Takeoff procedure should be executed. The pilot should maintain maximum brake pressure and reverse thrust until it is clear that the airplane will stop prior to the end of the runway. After stopping, the crew should insure the tower is aware of the rejected takeoff, notify the passengers/flight attendants, discuss the non-normal event, check the brake cooling charts, and taxi clear of the runway as appropriate.

3.2.4.2 Exercise 2, RTO with engine failure 5 knots prior to V_1 - Manual Braking

General Description

The initial conditions for this exercise should put the airplane at the maximum weight allowable for a dry runway and prescribed atmospheric conditions. Insure that this weight does not exceed the climb limit weight. The exercise uses an engine failure 5 knots (1 second) prior to V_1 to teach the pilot the stopping capabilities of the airplane and the margins that are incorporated in the Airplane Flight Manual. The pilot is instructed to reject the takeoff when the malfunction is observed. The RTO autobrakes are not available and should be selected to OFF. The pilot must perform the procedure properly in order to succeed.

Initial Conditions

Runway: KYKM Rwy 27
Airplane: 737-300 (CFM-56-3B-2 engines)
Airplane Gross Weight: 129,400 pounds/58,800 kgs
Takeoff Flaps: 5
Center of Gravity: 20%
Takeoff Thrust: Maximum thrust
 V_1 : 143 V_R : 144 V_2 : 151 Stabilizer Setting: 4 1/2
Ceiling and Visibility: Clear
Wind: Calm
Temperature: 86 F/30 C
Runway Condition: Dry
Airport Elevation: 1095 feet
Runway Length: 7603 feet
QNH: 29.92/1013

Piloting Technique Requirements

As the aircraft passes V_1 minus 5 knots, the engine should fail. Following engine failure the pilot should immediately bring the thrust to idle simultaneously applying maximum manual wheel brakes and complete the rejected takeoff procedure. The pilot must maintain maximum braking and full reverse thrust until the aircraft is completely stopped. Rudder must be used to counteract asymmetric thrust during the engine failure and when using reverse thrust. After stopping, the crew should insure the tower is aware of the rejected takeoff, notify the passengers/flight attendants, discuss the non-normal event, check the brake cooling charts, and taxi clear of the runway as appropriate.

3.2.4.3 Exercise 3, RTO with engine failure 5 knots prior to V_1 - Autobrakes

General Description

The initial conditions for this exercise should put the airplane at the maximum weight allowable for a dry runway and prescribed atmospheric conditions. Insure that this weight does not exceed the climb limit weight. The exercise uses an engine failure 5 knots (1 second) prior to V_1 to teach the pilot the stopping capabilities of the aircraft and the margins that are incorporated in the Airplane Flight Manual. The exercise will demonstrate the effectiveness of the autobrakes and increase pilot confidence in their use.

Initial Conditions

Runway: KYKM Rwy 27
Airplane: 737-300 (CFM-56-3B-2 engines)
Airplane Gross Weight: 129,400 pounds/58,800 kgs
Takeoff Flaps: 5
Center of Gravity: 20%
Takeoff Thrust: Maximum thrust
 V_1 : 143 V_R : 144 V_2 : 151 Stabilizer Setting: 4 1/2
Ceiling and Visibility: 3000 ft/3 miles
Wind: Calm
Temperature: 86 F/30 C
Runway Condition: Dry
Airport Elevation: 1095 feet
Runway Length: 7603 feet
QNH: 29.92/1013

Piloting Technique Requirements

As the aircraft passes V_1 minus 5 knots, the engine should fail. Following engine failure the pilot should immediately bring the thrust to idle and complete the rejected takeoff procedure. The pilot must monitor proper operation of the autobrakes and use full reverse thrust until the aircraft is completely stopped. After stopping, the crew should insure the tower is aware of the rejected takeoff, notify the passengers/flight attendants, discuss the non-normal event, check the brake cooling charts, and taxi clear of the runway as appropriate.

3.2.4.4 Exercise 4, RTO with engine failure 5 knots prior to V_1 - Wet runway with no corrections to weight or V_1

General Description

The initial conditions for this exercise should put the airplane at the maximum weight allowable for a dry runway and prescribed atmospheric conditions. Insure that this weight does not exceed the climb limit weight. The runway should be wet. The exercise uses an engine failure 5 knots (1 second) prior to V_1 to teach the pilot the stopping capabilities of the aircraft and the margins that are incorporated in the Airplane Flight Manual. The exercise will also demonstrate the impact of wet runways on stopping performance. If no correction is made to weight or V_1 , the aircraft should overrun the runway.

Initial Conditions

Runway: KYKM Rwy 27
Airplane: 737-300 (CFM-56-3B-2 engines)
Airplane Gross Weight: 129,400 pounds/58,800 kgs
Takeoff Flaps: 5
Center of Gravity: 20%
Takeoff Thrust: Maximum thrust
 V_1 : 143 V_R : 144 V_2 : 151 Stabilizer Setting: 4 1/2
Ceiling and Visibility: 3000 ft/3 miles
Wind: Calm
Temperature: 86 F/30 C
Runway Condition: Wet
Airport Elevation: 1095 feet
Runway Length: 7603 feet
QNH: 29.92/1013

Piloting Technique Requirements

As the aircraft passes V_1 minus 5 knots, the engine should fail. Following engine failure the pilot should execute the Rejected Takeoff procedure. The pilot must maintain maximum braking and use full reverse thrust until the aircraft is completely stopped. Estimate the speed passing the end of the runway. After stopping, the crew should insure the tower is aware of the rejected takeoff, notify the passengers / flight attendants, discuss the non-normal event, check the brake cooling charts.

3.2.4.5 Exercise 5, RTO with engine failure 5 knots prior to V_1 - Wet runway with wet runway corrections

General Description

The initial conditions for this exercise should put the airplane at the maximum weight allowable for a wet runway and prescribed atmospheric conditions. Insure that this weight does not exceed the climb limit weight. The runway should be wet. The exercise uses an engine failure 5 knots prior to V_1 to teach the pilot the stopping capabilities of the aircraft and the margins that are incorporated in the Airplane Flight Manual. The exercise will also demonstrate the impact of wet runways on stopping performance and the importance of correcting weight and V_1 to reduce stopping distance.

Initial Conditions

Runway: KYKM Rwy 27
Airplane: 737-300 (CFM-56-3B-2 engines)
Airplane Gross Weight: 127,500 pounds/58,000 kgs
Takeoff Flaps: 5
Center of Gravity: 20%
Takeoff Thrust: Maximum thrust
 V_1 : 132 V_R : 142 V_2 : 150 Stabilizer Setting: 4 1/2
Ceiling and Visibility: 3000 ft/3 miles
Wind: Calm
Temperature: 86 F/30 C
Runway Condition: Wet
Airport Elevation: 1095 feet
Runway Length: 7603 feet
QNH: 29.92/1013

Piloting Technique Requirements

As the aircraft passes V_1 minus 5 knots, the engine should fail. Following engine failure, the pilot should execute the Rejected Takeoff procedure. The pilot must maintain maximum braking and full reverse thrust until the aircraft is completely stopped. After stopping, the crew should insure the tower is aware of the rejected takeoff, notify the passengers / flight attendants, discuss the non-normal event, check the brake cooling charts, and taxi clear of the runway as appropriate.

3.2.4.6 Exercise 6, Takeoff continued with engine failure 5 knots prior to V_1

General Description

The initial conditions for this exercise should put the airplane at the maximum weight allowable for a dry runway and prescribed atmospheric conditions. Insure that this weight does not exceed the climb limit weight. The exercise uses an engine failure 5 knots prior to V_1 to teach the pilot the margins that are incorporated in the Airplane Flight Manual for the takeoff case. The pilot is instructed to continue the takeoff when the malfunction is observed. With instructor assistance, the pilot not flying will note the radio altitude of the airplane as it passes the end of the runway. The pilot flying should concentrate on maintaining proper aircraft control.

Initial Conditions

Runway: KYKM Rwy 27
Airplane: 737-300 (CFM-56-3B-2 engines)
Airplane Gross Weight: 129,400 pounds/58,800 kgs
Takeoff Flaps: 5
Center of Gravity: 20%
Takeoff Thrust: Maximum thrust
 V_1 : 143 V_R : 144 V_2 : 151 Stabilizer Setting: 4 1/2
Ceiling and Visibility: 3000 ft/3 miles
Wind: Calm
Temperature: 86 F/30 C
Runway Condition: Dry
Airport Elevation: 1095 feet
Runway Length: 7603 feet
QNH: 29.92/1013

Piloting Technique Requirements

As the aircraft passes V_1 minus 5 knots, the engine should fail. Expertise gained during previous lesson(s) regarding engine failure during takeoff should be used to maintain aircraft control, and complete the climb out.

3.2.4.7 Exercise 7, Blown tire at V_1 -10 knots

General Description

The initial conditions for this exercise are not defined, however a demonstration of a field length limit weight stop can be useful. The malfunction can be introduced in the course of normal training during a takeoff in which no other specific teaching point is being made. A failure at 10 knots prior to V_1 gives the crew adequate time to consider the proper course of action. It is generally considered most appropriate to continue the takeoff in this situation. If this is the decision that is made, it should be positively reinforced. If the "stop" decision is made, the merits of that course of action should be discussed.

Initial Conditions

No special initial conditions are required for this training.

Piloting Technique Requirements

Unusual malfunctions require good crew coordination and communication. If the pilot chooses to continue the takeoff, it should be flown under control with consideration of whether or not to retract the gear. If the pilot chooses to reject the takeoff, the RTO must be performed accurately with good crew coordination including notification of passengers and ATC. The proper use of the appropriate checklists and brake cooling charts should be emphasized.

3.2.4.8 Exercise 8, Indicator failure/cockpit alert or advisory light at V₁-10 knots

General Description

Such malfunctions are unique to specific airplane models and should be chosen to reflect operational experience to enhance realism and learning. The purpose of the training is to emphasize company guidance to "Go" in such cases. Positive reinforcement with a brief explanation should follow a decision to continue the takeoff. A rejected takeoff should be followed with a discussion of the merits of that decision and a clarification of company policy.

Initial Conditions

No special initial conditions are required for this training.

Piloting Technique Requirements

Unusual malfunctions require good crew coordination and communication. If the pilot chooses to continue the takeoff, it should be flown under control. If the pilot chooses to reject the takeoff, the RTO must be performed accurately with good crew coordination including notification of passengers and ATC. The proper use of the appropriate checklists and brake cooling charts should be emphasized.

3.2.5 Exercises With Other Models

Similar exercises for other airplane models are contained in Appendix 3-D.

3.3 Simulator Implementation Guide

This section is designed to assist the simulator programming/checkout department. No new models have to be added to the current simulators to enable quality RTO training to be done. The challenge is to ensure that the simulator accurately reflects the current simulator ground handling documents and that it accurately introduces malfunctions in a timely manner.

3.3.1 Simulator Fidelity Checks

Operators that use this training aid should assure that simulator scenarios accurately reflect aircraft characteristics and performance to the extent necessary to achieve training objectives. Scenarios should not be used that have unrealistic simulator characteristics that contribute to negative training. In general, certified simulators contain testing programs that enable simulator engineers to confirm the accuracy of the aircraft simulation. These tests are normally done automatically from a landing and are adequate to give good braking simulation during an RTO. When purchasing new simulators, assure that data from the manufacturer is up to date in order to do appropriate RTO training. When simulator characteristics do not adequately model aircraft performance, it may be necessary to adjust weights, friction coefficients, runway lengths or other appropriate parameters to assure the scenario supports the training objective sought. For example, if the simulator is found to out perform the airplane, the instructor might set a gross weight that is higher than called for in the lesson, but causes an outcome that is consistent with the training objective. The concept is to meet the training objectives taking full advantage of the existing simulator quality and improve that quality when the opportunity presents itself.

A simple check of simulator fidelity can be conducted by looking up the applicable numbers in the airplane's flight manual or performance manual and doing a proper RTO without reverse thrust and observing the stopping distance. If the brakes are applied and held to the maximum at V_1 while simultaneously

bringing the thrust to idle, then raising the speedbrake handle, the simulator should stop prior to the end of the runway with a small distance margin remaining. If this is not the case, the simulator should be modified so that it will be able to successfully replicate a flight manual stop.

3.3.2 Tuning for Accomplishment of Objectives

Manufacturer's ground handling simulator documents contain tire-to-ground friction characteristics for a variety of runway surface conditions including dry, wet (smooth, ungrooved pavements) and contaminated (ice, snow, and rubber deposits). Due to the wide variation of friction available from wet runways depending on the surface texture, tire parameters and the depth of the water film, manufacturer's simulator documents provide a range of friction values versus groundspeed for wet runway simulation. This allows the airline and/or simulator manufacturer to adjust the stopping performance as required to represent particular runway situations by selecting a specific friction versus speed curve function. If the stopping distance appears to be too short (too long), the wet runway friction curve can be factored down (up) until the desired result is obtained.

3.3.3 Grooved Runways

For grooved runways, which now comprise 87% of the runways used by large jet transport airplanes within the US, the wet friction characteristic is substantially better than for smooth pavements. Very little airplane stopping performance has been established for wet grooved runways. However, flight tests on at least one model show that for the landing speed range, a wet grooved runway develops an average of approximately 95% of the dry runway friction. Since the speed range for RTO's is generally higher than for landing, it is suggested that operators use 85% of the dry runway friction curve from the simulator document until further analysis or other substantiating data is obtained.

(This page intentionally left blank)

Example Takeoff Safety Training Program

List of Appendices

Training Aid Appendix Number	Title and Contents
3-A	<p>Instructor Pilot Syllabus Briefing Supplement Additional information intended to assist the instructor in preparation of academic and simulator training programs.</p>
3-B	<p>Pilot Guide to Takeoff Safety Questions Questions designed to test a pilot's knowledge of the material contained in the Pilot Guide to Takeoff Safety. The questions are multiple choice and an instructor examination guide and answer key are included.</p>
3-C	<p>Takeoff Safety Briefing A paper copy of view foils with descriptive words for each one that can be used for a classroom presentation. The briefing supports a classroom discussion of the Pilot Guide and/or the optional video.</p>
Manufacturers' Model Specific Data Appendix Number	Title and Contents
3-D	<p>Simulator Exercises Example training exercises for specific airplane models provided to operators by airframe manufacturers.</p>
3-E	<p>Optional Takeoff Safety Video Script A written copy of the script for the optional video program, <i>REJECTED TAKEOFF AND THE "GO/NO GO" DECISION</i>.</p>

(This page intentionally left blank)

Instructor Pilot Syllabus Briefing Supplement

3-A

The rejected takeoff (RTO), as presented in the Operations Manual, is a comprehensive procedure to accomplish any rejected takeoff. This procedure is based on the worst case situation: i.e.; field length limited with an engine failure just prior to V_1 . Clearly there are legitimate reasons, other than an engine failure, for rejecting a takeoff, especially at lower speeds. As the speed approaches V_1 , however, the reasons to reject become limited to an engine failure/fire or a situation judged by the Captain to constitute an emergency that could endanger the safety of the aircraft if the takeoff were continued. The Captain is responsible by FAR for the safety of the passengers, crew, and airplane and may exercise decisions and actions as required up to the provisions of emergency authority (FAR 121.557 or .559, Atch 1) if deemed necessary.

The following information may be used to enhance simulator prebriefings. The pilot's "mind-set" concerning what V_1 actually represents in the Go/No Go decision process is of primary importance.

I. Basic Education Factors:

A. Definitions.

Certain definitions are needed to explain the concepts discussed in the training aid. Some of the definitions used are taken from the FAR's or other references, and some are defined in the training aid. Where appropriate, the training aid definition has been written from the point of view of the pilot and may clarify or expand on the regulatory definition to the extent necessary to assure appropriate flight crew action.

1) V_1 . FAR definition:

V_1 means takeoff decision speed (formerly denoted as critical engine failure speed).

2) V_1 . Training Aid Definition:

The speed selected for each takeoff, based upon approved performance data and specified conditions, which represents:

- a. The maximum speed by which a rejected takeoff must be initiated to assure that a safe stop can be completed within the remaining runway or runway and stopway, and
- b. The minimum speed which assures that a takeoff can be safely completed within the remaining runway, or runway and clearway, after failure of the most critical engine at a designated speed, and
- c. The single speed which permits a successful stop or continued takeoff when operating at the minimum allowable field length for a particular weight.

Note 1: Safe completion of the takeoff includes both attainment of the designated screen height at the end of the runway or clearway, and safe obstacle clearance along the designated takeoff flight path.

Note 2: Reference performance conditions for determining V_1 may not necessarily account for all variables possibly affecting a takeoff, such as runway surface friction, failures other than a critical engine, etc.

3) Minimum V_1 : The minimum permissible V_1 speed for the reference conditions from which the takeoff can be safely completed from a given runway or runway and clearway, after the critical engine has failed at the designated speed.

4) Maximum V_1 : The maximum permissible V_1 speed for the reference conditions at which a rejected takeoff can be initiated and the airplane stopped within the remaining runway or runway and stopway.

5) Reduced V_1 : A V_1 less than the maximum V_1 or the normal V_1 but more than the minimum V_1 , selected to reduce the RTO stopping distance required.

Note: Wet or slippery V_1 speeds are reduced V_1 's used to adjust the RTO stopping distance for the degraded stopping capability associated with these conditions. Reducing V_1 for a dry runway takeoff, when conditions permit, will provide additional stopping margin in the event of an RTO. In either case, the reduced V_1 must be determined so as to also assure the continued takeoff criteria are met (i.e. screen height, obstacle clearance and V_{mcg}).

6) Decision time:

The time between failure of the critical engine and/or any other event which requires the pilot to make a Go/No Go decision, and V_1 .

After V_1 , there is no decision time allowance provided in the airplane performance data. To stop within the predetermined accelerate-stop distance, stopping action must begin no later than V_1 .

7) V_R : Rotation speed

8) V_{LOF} : Lift off speed

9) V_2 : Minimum takeoff safety speed

10) Screen Height: The height of an imaginary screen which the airplane would just clear at the end of the runway or runway and clearway in an unbanked attitude with the landing gear extended.

11) Takeoff Distance: The horizontal distance from the start of the takeoff to the point where the airplane reaches the prescribed screen height above the surface with a critical engine having failed at the

designated speed or, 115% of the horizontal distance from the start of takeoff to the point where the airplane reaches the prescribed screen height above the surface with all engines operating.

12) Accelerate-Go Distance: The horizontal distance from the start of the takeoff to the point where the airplane reaches the prescribed screen height above the takeoff surface with the critical engine having failed at the designated speed.

13) Accelerate-Stop Distance: The horizontal distance from the start of the takeoff to the point where the airplane is stopped on the runway or runway and stopway, when the stop is initiated at V_1 and completed using the approved procedures and specified conditions.

14) Balanced Field length: The runway length (or runway plus clearway and/or stopway) where, for the takeoff weight, the engine-out accelerate-go distance equals the accelerate-stop distance. In more detail, it exists when the airplane performance is such that for an engine failure one second prior to V_1 , the distance required to accelerate on the remaining engine(s), takeoff, climb to the prescribed screen height and reach V_2 speed, is equal to the distance required to initiate the reject at V_1 and stop. When this distance is equal to the runway length this is termed a "Balanced Field Length". The weight associated with this is termed the "Balanced Field Weight Limit". This is the speed typically given to flight crews.

15) Critical Field length: The minimum runway length (or runway plus clearway and/or stopway) required for a specific takeoff weight. This distance may be the longer of the balanced field length, 115% of the all engine takeoff distance, or established by other limitations such as maintaining V_1 to be less than or equal to V_R .

16) Derated Takeoff Thrust: A takeoff thrust level less than the maximum takeoff thrust approved for an airplane/engine for which a separate and specific set of data which complies with all of the

requirements of part 25 of the FAR's exists. When operating with a derated takeoff thrust, the thrust setting parameter used to establish thrust for takeoff is presented in the AFM and is considered an operating limit for that takeoff.

17) **Reduced Takeoff Thrust:** A takeoff thrust level less than the maximum (or derated) takeoff thrust. The takeoff performance and thrust settings are established by approved simple methods, such as adjustments or corrections to the takeoff performance and thrust settings defined for the maximum thrust (or derated) performance and thrust settings. When operating with a reduced takeoff thrust, the thrust setting parameter used to establish thrust for takeoff is not considered an operating limit; The thrust may be restored to the maximum (or derate) level as appropriate for the conditions of the flight at any time during the takeoff.

18) **Clearway:** A cleared area beyond the end of the runway, not less than 500 feet wide, centrally located about the extended center line of the runway, that contains no obstructions and under the control of the airport authorities.

19) **Stopway:** An area beyond the end of the runway, at least as wide as the runway and centered along the extended center line of the runway, able to support the airplane during a rejected takeoff without causing structural damage to the airplane, and designated by the authorities for use in decelerating the airplane during a rejected takeoff.

20) **Rejected Takeoff:** A takeoff that is discontinued after takeoff thrust is set and initiation of the takeoff roll has begun.

B. Reasons to reject.

Reasons to reject at low speed: System failure(s), unusual noise or vibration, tire failure, abnormally slow acceleration, engine failure, engine fire, unsafe takeoff configuration warning or the aircraft is unsafe or unable to fly.

Reasons to reject at high speed: Engine failure/ fire, aircraft unsafe or unable to fly.

C. Flight Manual Margins.

To stop within the precomputed accelerate-stop distance, the first stopping action must begin by V_1 . The RTO procedure must be executed accurately and expeditiously. Doing the procedure quickly and using maximum available reverse thrust give additional stopping margin.

II. Practical

A. Guidelines.

The following practical guidelines will be used in the instruction and education of pilots concerning a Go/No Go decision during takeoff:

- 1) The Operations Manual/ Aircraft Operating Manual procedure.
- 2) A thorough understanding of the definitions/factors governing V_1 speeds and their effects on the reject process as outlined in Section I.
- 3) Captain's responsibilities:
 - a. Make all Go/No Go decisions.
 - b. Exercise emergency authority as required.
 - c. Ensure a departure briefing including a comprehensive takeoff plan based on: gross weight, runway length, field conditions, weather, and any other factors that may affect a particular takeoff as it relates to a Go/No Go decision is made.
 - d. Know airplane's performance capabilities.
- 4) Rejected takeoffs can have an operational range from a low speed situation to a high speed balanced field length condition. The primary training goal is to recognize the variables that may affect the decision and to become proficient in the high risk, critical end of the reject scenario.
 - a. Low speed rejected takeoffs - characterized by speeds of approximately 80 knots or less. Use normal Operations Manual reject procedures but may require less than maximum braking during deceleration to safely stop.

b. High speed/field length limited rejected takeoffs - reject decision time influenced by systematically disregarding system malfunctions up to a point approaching V_1 . At this point, a decision to stop is recommended only for an engine failure or a malfunction where there is doubt that the aircraft will fly safely. This requires the use of operations manual reject procedures with maximum braking and deceleration techniques.

5) Because V_1 marks the end of the Go/No Go decision time, the PNF must complete the V_1 call by V_1 in a clear, crisp manner.

6) Discuss:

- a. Tower communications, including the request for fire fighting equipment if required
- b. Non-normal procedure
- c. Passenger notification/evacuation
- d. Brake cooling charts
- e. Log book write-up
- f. Clearing the runway/advisability of returning to the gate

III. Syllabus Rejected Takeoffs

The following discussion refers to Appendix 3-D which contains example simulator exercises appropriate for the specific airplane model of interest. These simulator exercises should be modified for use by each operator. The examples given are illustrative in nature and are not designed to be used by any specific operator.

During the first lesson in which RTO's are introduced to a crew, it is suggested that Exercise 1 be used to develop crew proficiency in the RTO.

More challenging RTO's should be introduced in a lesson after engine-out proficiency is attained. It is suggested that Exercises 2 through 6 be presented one after another, so the crew can compare stopping performance. Exercise 5 is only for operators who actually do make wet runway corrections to takeoff data.

In the lessons that follow this lesson, additional exercises such as a blown tire or an indicator failure/cockpit alert or advisory light can be introduced during takeoffs in which there is not a conflicting teaching point in order to enhance decision making.

Normally, the simulator lesson prior to the evaluation should include a representative sample of the type of RTO's given on evaluation flights, again emphasizing good decision making and proper procedure execution. The content of the evaluation flight is normally dictated by the regulatory agency.

Attachment 1

PART 121 AIR CARRIERS AND COMMERCIAL OPERATORS OF LARGE AIRCRAFT 89

§ 121.557 Emergencies: domestic and flag air carriers

(a) In an emergency situation that requires immediate decision and action the pilot in command may take any action that he considers necessary under the circumstances. In such a case he may deviate from prescribed operations procedures and methods, weather minimums, and this chapter, to the extent required in the interests of safety.

(b) In an emergency situation arising during flight that requires immediate decision and action by an aircraft dispatcher, and that is known to him, the aircraft dispatcher shall advise the pilot in command of the emergency, shall ascertain the decision of the pilot in command, and shall have the decision recorded. If the aircraft dispatcher cannot communicate with the pilot, he shall declare an emergency and take any action that he considers necessary under the circumstances.

(c) Whenever a pilot in command or dispatcher exercises emergency authority, he shall keep the appropriate ATC facility and dispatch centers fully informed of the progress of the flight. The person declaring the emergency shall send a written report of any deviation through the air carrier's operations manager, to the Administrator. A dispatcher shall send his report within 10 days after the date of the emergency, and a pilot in command shall send his report within 10 days after returning to his home base.

§ 121.559 Emergencies: supplemental air carriers and commercial operators.

(a) In an emergency situation that requires immediate decision and action, the pilot in command may take any action that he considers necessary under the circumstances. In such a case, he may deviate from prescribed operations, procedures and methods, weather minimums, and this chapter, to the extent required in the interests of safety.

(b) In an emergency situation arising during flight that requires immediate decision and action by appropriate management personnel in the case of

operations conducted with a flight following service and which is known to them, those personnel shall advise the pilot in command of the emergency, shall ascertain the decision of the pilot in command, and shall have the decision recorded. If they cannot communicate with the pilot, they shall declare an emergency and take any action that they consider necessary under the circumstances.

(c) Whenever emergency authority is exercised, the pilot in command or the appropriate management personnel shall keep the appropriate management personnel shall keep the appropriate ground radio station fully informed of the progress of the flight. The person declaring the emergency shall send a written report of any deviation, through the air carrier's or commercial operator's director of operations, to the Administrator within 10 days after the flight is completed or, in the case of operations outside the United States, upon return to the home base.

§ 121.561 Reporting potentially hazardous meteorological conditions and irregularities of ground and navigation facilities.

(a) Whenever he encounters a meteorological condition or an irregularity in a ground or navigational facility, in flight, the knowledge of which he considers essential to the safety of other flights, the pilot in command shall notify an appropriate ground station as soon as practicable.

(b) The ground radio station that is notified under paragraph (a) of this section shall report the information to the agency directly responsible for operating the facility.

§ 121.563 Reporting mechanical irregularities

The pilot in command shall ensure that all mechanical irregularities occurring during flight time are entered in the maintenance log of the airplane at the end of that flight time. Before each flight the pilot in command shall ascertain the status of each irregularity entered in the log at the end of the preceding flight.

(This page intentionally left blank)

Pilot Guide to Takeoff Safety Questions

3-B

Included in the following appendix are questions designed to test a pilot's knowledge of the material contained in the Pilot Guide to Takeoff Safety. The questions are all multiple choice.

The first part of this appendix is the Student Examination. Instructions for answering the questions are provided.

The second part of this appendix is the Instructor Examination Guide. This part contains the questions in the Student Examination, the correct answers to each question and the section in the Pilot Guide to Takeoff Safety where the correct answer may be found.

Table of Contents

Section	Page
Student Examination	3-B.1
Instructor Examination Guide	3-B.9
Summary of Answers	3-B.18

(This page intentionally left blank)

Student Examination

Instructions

These questions are based on the material in the Pilot Guide to Takeoff Safety. The answers to each question can be found in that document. The questions are all multiple choice. Circle the one answer to each question which is most correct.

Questions

- 1) Statistically, 1 RTO occurs for every _____ takeoffs.
 - A) 1000
 - B) 3000
 - C) 7000
 - D) 10,000

- 2) Most RTO's are initiated at speeds _____ .
 - A) of 80 knots or less
 - B) between 80 and 120 knots
 - C) near V_1 (within 10 knots)
 - D) above V_1

- 3) Every pilot must be prepared to make the correct Go/No Go decision _____ .
 - A) in the event of an engine failure or fire
 - B) if it is certain the airplane is unsafe or unable to fly
 - C) either A or B
 - D) on every takeoff

- 4) Most RTO's are _____ .
 - A) engine-related events
 - B) wheel/tire events
 - C) non-engine events

- 5) The majority of past RTO overrun accidents/incidents were initiated at _____ .
 - A) speeds below V_1
 - B) speeds above V_1

- 6) Of past RTO overrun accidents and serious incidents about _____ of the RTO's were initiated because of engine failures or indication warnings.
- A) one fourth
 - B) half
 - C) three fourths
 - D) all
- 7) Full takeoff power was available during approximately _____ of past RTO accidents.
- A) 25%
 - B) 50%
 - C) 75%
 - D) 100%
- 8) In a review of past accident records of revenue flights involving Go/No Go decisions, of the cases where a GO decision was made, _____ of the airplanes failed to make a safe landing.
- A) virtually none
 - B) 10%
 - C) 25%
 - D) More than 75%
- 9) In the majority of past RTO overrun accidents and serious incidents, if the takeoff had been continued, _____.
- A) an uneventful landing would probably have resulted
 - B) the airplane probably would have crashed
- 10) In a situation where the gross weight is limited by field length, _____ of the runway is typically left from V_1 to stop the airplane.
- A) 60%
 - B) 50%
 - C) 40%

- 11) On a dry runway, if an engine fails approximately 1 second before V_1 , the FAR criteria requires the airplane to reach a minimum height of _____ by the end of the runway.
- A) 15 feet
 - B) 35 feet
 - C) 50 feet
- 12) V_1 is _____.
- A) the latest point during a takeoff in which the gross weight is limited by the field length, where a stop can be initiated and the airplane stopped by the end of the runway
 - B) the earliest point during takeoff in which the gross weight is limited by the field length, at which an engine out takeoff can be continued and the airplane reach a height of 35 feet at the end of the runway
 - C) an action speed
 - D) all of the above
- 13) In a situation in which the gross weight is limited by field length, the Go/No Go decision must be made _____.
- A) before reaching V_1
 - B) after reaching V_1
- 14) During a takeoff in which the gross weight is limited by field length, if an engine fails approximately 1 second prior to V_1 and the decision is made to reject the takeoff, according to the AFM the airplane will come to a stop _____.
- A) at the very end of the runway
 - B) well before the end of the runway
 - C) beyond the end of the runway
 - D) before the end of the runway, only if aerodynamic braking is used
- 15) In a Balanced Field takeoff, _____.
- A) the runway required to accelerate to V_1 exactly equals the runway length required to decelerate from V_1 to a stop
 - B) the runway length required to accelerate, lose an engine approximately one second before V_1 and either bring the airplane to a stop, or continue the takeoff and reach 35 feet above the runway at V_2 is exactly the same
 - C) takeoff roll exactly equals landing roll if an emergency return is required
 - D) the cost of the passengers tickets exactly equals the salaries of the crew

- 16) Actual flight test accelerate-stop distances are increased by several hundred feet in the AFM _____ .
- A) to allow the crew more time to make the decision to stop or not to stop
 - B) because reverse thrust was not used in the flight tests
 - C) to allow for unknown variables such as runway condition or contamination and pilot technique
 - D) to allow the line crew more time to execute the stopping action
- 17) In a situation in which the gross weight is limited by field length, if an engine fails 2 seconds before V_1 , the airplane will be able to cross the end of the runway at a height of _____ .
- A) 2 - 10 feet
 - B) 15 - 30 feet
 - C) 35 feet or more
- 18) During a takeoff in which the gross weight is limited by field length, if an engine fails two seconds before V_1 and the decision is made to continue the takeoff, the airplane will _____ .
- A) not reach rotate speed before the end of the runway
 - B) reach V_2 at less than 35 feet above the end of the runway
 - C) reach takeoff speed at the end of the runway
- 19) When an RTO is necessary on a wet or slippery runway, the pilot should _____ .
- A) pump the brakes to minimize excessive anti skid cycling
 - B) avoid large puddles
 - C) wait until near the end of the runway to apply full braking
 - D) bring the airplane to a complete stop once an RTO has been initiated
- 20) Selecting a larger flap setting for takeoff will result in _____ .
- A) a longer takeoff roll
 - B) a lower V_1 speed
 - C) improved climb performance
 - D) decreased airplane drag

- 21) The use of engine bleed air for air conditioning/pressurization _____ .
- A) has no effect on takeoff performance
 - B) reduces takeoff performance
 - C) increases the thrust the engine provides
- 22) The pilot can minimize the probability of a tire failure during takeoff by _____ .
- A) taxiing quickly to avoid excessive delays getting to the runway
 - B) using low taxi speeds and minimum braking whenever possible
 - C) ignoring the time and weight limits of the Max Quick Turnaround Weight Charts
 - D) maintain steady pressure on the brakes throughout the taxi to avoid excessive speed
- 23) In the event of a tire failure during takeoff, _____ .
- A) the crew should always reject the takeoff because of the possibility of other associated problems, such as hydraulic system failures or tire pieces ingested into the engines
 - B) the crew should always continue the takeoff so that the entire runway can be used for stopping on the subsequent landing
 - C) the crew's indication is always a loud bang and a significant pulling to one side
 - D) the stopping capability of the airplane may be significantly degraded
- 24) Delaying or not raising the speedbrake during an RTO _____ .
- A) will have no effect on stopping distance
 - B) can be compensated for by proper aerodynamic braking technique
 - C) can be compensated for by using reverse thrust
 - D) will result in a longer stopping distance
- 25) On today's high bypass ratio engines, reverse thrust _____ .
- A) greater than idle reverse should not be used in order to minimize stopping distance required
 - B) is less effective at higher speeds
 - C) generates a larger percentage of the total airplane deceleration on wet or slippery runways
 - D) is extremely effective, particularly on dry runways

- 26) Use of a clearway for takeoff results in _____.
- A) a lower V_1 speed and increased maximum weight
 - B) a lower V_1 speed and decreased maximum weight
 - C) a higher V_1 speed and increased maximum weight
 - D) a higher V_1 speed and decreased maximum weight
- 27) When using the Assumed Temperature Method for reducing takeoff thrust, _____.
- A) V_{mcg} and V_{mca} are reduced to correspond to the takeoff thrust being used
 - B) with an engine failure at the associated V_1 speed, a 35 foot height above the end of the runway may not be attainable without increasing thrust to the actual maximum rated thrust
 - C) the actual true air speed is lower than it would be if the actual temperature were equal to the assumed temperature
 - D) the actual true airspeed is higher than it would be if the actual temperature were equal to the assumed temperature
- 28) Which of the following is not a correct guideline for crews related to eliminating RTO overrun incidents?
- A) Do not initiate a stop after V_1 unless you suspect that a tire has failed or a catastrophic engine failure has occurred.
 - B) Don't change your mind, if you have begun an RTO, stop. If you have passed V_1 , go, unless the pilot has reason to conclude that the airplane is unsafe or unable to fly.
 - C) Both pilots must be sure to position the seat and rudder pedals so that maximum brake pressure can be applied.
 - D) Use maximum effort brake application.
- 29) Minimum takeoff distance can be achieved by _____.
- A) sacrificing some runway line-up distance, so that thrust can be advanced for takeoff during the turn onto the runway
 - B) minimizing runway line-up distance by a sharper turn to line-up and setting takeoff power prior to releasing the brakes
 - C) slowly advancing thrust while rolling down the runway before engaging the autothrottle
 - D) line-up distance and setting takeoff thrust have minimal impact on takeoff distance

- 30) If you use manual braking for a rejected takeoff, _____.
- A) pump the brakes to minimize skidding
 - B) maintain full brake pedal force
 - C) release braking when reverse thrust is applied
- 31) During a rejected takeoff from V_1 , a good technique is to use maximum braking and full reverse thrust _____.
- A) until the airplane comes to a complete stop
 - B) until below 60 knots, then decrease reverse thrust to reduce the likelihood of compressor stalls
 - C) until the crew judges the remaining runway is sufficient for stopping with less than maximum effort
 - D) at high speeds, reducing braking at lower speeds to prevent fuse plugs from melting, since reverse thrust will further decrease stopping distance
- 32) For an RTO with anti-skid inoperative _____.
- A) the RTO procedure is unchanged
 - B) brakes should be applied immediately after reducing power to idle
 - C) brakes should be applied after the speedbrake is raised
 - D) full brake pressure should only be applied at high speeds
- 33) On the average, RTO's performed with RTO autobrakes armed result in _____ runway distance remaining after a stop than do RTO's performed using manual braking only.
- A) more
 - B) less
 - C) the same
- 34) The Go/No Go decision must be made by _____.
- A) the chief pilot and training staff
 - B) the crew flying
 - C) airline policies and guidelines
 - D) developing correct regulations

(This Page intentionally left blank)

Instructor Examination Guide

Instructions

This guide contains questions based on the material in the Pilot Guide to Takeoff Safety. The answers to each question can be found in that document. The questions are all multiple choice. There is one answer to each question which is most correct.

The correct answer is listed after each question, along with the section in the Pilot Guide to Takeoff Safety where the correct answer may be found.

Questions

1) Statistically, 1 RTO occurs for every _____ takeoffs.

- A) 1000
- B) 3000
- C) 7000
- D) 10,000

Answer: B (Section 2.2.1)

2) Most RTO's are initiated at speeds _____.

- A) of 80 knots or less
- B) between 80 and 120 knots
- C) near V_1 (within 10 knots)
- D) above V_1

Answer: A (Section 2.2.1)

3) Every pilot must be prepared to make the correct Go/No Go decision _____.

- A) in the event of an engine failure or fire
- B) if it is certain the airplane is unsafe or unable to fly
- C) either A or B
- D) on every takeoff

Answer: D (Section 2.2.1)

4) Most RTO's are _____.

- A) engine-related events
- B) wheel/tire events
- C) non-engine events

Answer: C (Section 2.2.4)

- 5) The majority of past RTO overrun accidents/incidents are initiated at _____ .
- A) speeds below V_1
 - B) speeds above V_1

Answer: B (Section 2.2.4)

- 6) Of past RTO overrun accidents and serious incidents about _____ of the RTO's were initiated because of engine failures or indication warnings.
- A) one fourth
 - B) half
 - C) three fourths
 - D) all

Answer: A (Section 2.2.4)

- 7) Full takeoff power was available during approximately _____ of past RTO accidents.
- A) 25%
 - B) 50%
 - C) 75%
 - D) 100%

Answer: C (Section 2.2.4, 2.3.3)

- 8) In a review of past accident records of revenue flights involving Go/No Go decisions, of the cases where a GO decision was made, _____ of the airplanes failed to make a safe landing.
- A) virtually none
 - B) 10%
 - C) 25%
 - D) More than 75%

Answer: A (Section 2.2.4)

- 9) In the majority of past RTO overrun accidents and serious incidents, if the takeoff had been continued, _____ .
- A) an uneventful landing would probably have resulted
 - B) the airplane probably would have crashed

Answer: A (Section 2.2.5)

10) In a situation where the gross weight is limited by field length, _____ of the runway is typically left from V_1 to stop the airplane.

- A) 60%
- B) 50%
- C) 40%

Answer: C (Section 2.3.1.1)

11) On a dry runway, if an engine fails approximately 1 second before V_1 , the FAR criteria requires the airplane to reach a minimum height of _____ by the end of the runway.

- A) 15 feet
- B) 35 feet
- C) 50 feet

Answer: B (Section 2.3.1.1)

12) V_1 is _____.

- A) the latest point during a takeoff in which the gross weight is limited by the field length, where a stop can be initiated and the airplane stopped by the end of the runway
- B) the earliest point during takeoff in which the gross weight is limited by the field length, at which an engine out takeoff can be continued and the airplane reach a height of 35 feet at the end of the runway
- C) an action speed
- D) all of the above

Answer: D (Section 2.3.1.2)

13) In a situation in which the gross weight is limited by field length, the Go/No Go decision must be made _____.

- A) before reaching V_1
- B) after reaching V_1

Answer: A (Section 2.3.1.2)

14) During a takeoff in which the gross weight is limited by field length, if an engine fails approximately 1 second prior to V_1 and the decision is made to reject the takeoff, according to the AFM the airplane will come to a stop _____.

- A) at the very end of the runway
- B) well before the end of the runway
- C) beyond the end of the runway
- D) before the end of the runway, only if aerodynamic braking is used

Answer: A (Section 2.3.1.2)

- 15) In a Balanced Field takeoff, _____ .
- A) the runway required to accelerate to V_1 exactly equals the runway length required to decelerate from V_1 to a stop
 - B) the runway length required to accelerate, lose an engine approximately one second before V_1 and either bring the airplane to a stop , or continue the takeoff and reach 35 feet above the runway at V_2 is exactly the same
 - C) takeoff roll exactly equals landing roll if an emergency return is required
 - D) the cost of the passengers tickets exactly equals the salaries of the crew

Answer: B (Section 2.3.1.3)

- 16) Actual flight test accelerate-stop distances are increased by several hundred feet in the AFM _____ .
- A) to allow the crew more time to make the decision to stop or not to stop
 - B) because reverse thrust was not used in the flight tests
 - C) to allow for unknown variables such as runway condition or contamination and pilot technique
 - D) to allow the line crew more time to execute the stopping action

Answer: D (Section 2.3.2.2)

- 17) In a situation in which the gross weight is limited by field length, if an engine fails 2 seconds before V_1 , the airplane will be able to cross the end of the runway at a height of _____ .
- A) 2 - 10 feet
 - B) 15 - 30 feet
 - C) 35 feet or more

Answer: B (Section 2.3.3.2)

- 18) During a takeoff in which the gross weight is limited by field length, if an engine fails two seconds before V_1 and the decision is made to continue the takeoff, the airplane will _____ .
- A) not reach rotate speed before the end of the runway
 - B) reach V_2 at less than 35 feet above the end of the runway
 - C) reach takeoff speed at the end of the runway

Answer: B (Section 2.3.3.2)

19) When an RTO is necessary on a wet or slippery runway, the pilot should _____ .

- A) pump the brakes to minimize excessive anti skid cycling
- B) avoid large puddles
- C) wait until near the end of the runway to apply full braking
- D) bring the airplane to a complete stop once an RTO has been initiated

Answer: D (Section 2.3.5.1.2)

20) Selecting a larger flap setting for takeoff will result in _____ .

- A) a longer takeoff roll
- B) a lower V_1 speed
- C) improved climb performance
- D) decreased airplane drag

Answer: B (Section 2.3.5.3.1)

21) The use of engine bleed air for air conditioning/pressurization _____ .

- A) has no effect on takeoff performance
- B) reduces takeoff performance
- C) increases the thrust the engine provides

Answer: B (Section 2.3.5.3.2)

22) The pilot can minimize the probability of a tire failure during takeoff by _____ .

- A) taxiing quickly to avoid excessive delays getting to the runway
- B) using low taxi speeds and minimum braking whenever possible
- C) ignoring the time and weight limits of the Max Quick Turnaround Weight Charts
- D) maintaining steady pressure on the brakes throughout the taxi to avoid excessive speed

Answer: B (Section 2.3.5.3.4)

23) In the event of a tire failure during takeoff, _____ .

- A) the crew should always reject the takeoff because of the possibility of other associated problems, such as hydraulic system failures or tire pieces ingested into the engines
- B) the crew should always continue the takeoff so that the entire runway can be used for stopping on the subsequent landing
- C) the crew's indication is always a loud bang and a significant pulling to one side
- D) the stopping capability of the airplane may be significantly degraded

Answer: D (Section 2.3.5.3.4)

- 24) Delaying or not raising the speedbrake during an RTO _____ .
- A) will have no effect on stopping distance
 - B) can be compensated for by proper aerodynamic braking technique
 - C) can be compensated for by using reverse thrust
 - D) will result in a longer stopping distance

Answer: D (Section 2.3.5.3.7)

- 25) On today's high bypass ratio engines, reverse thrust _____ .
- A) greater than idle reverse should not be used in order to minimize stopping distance required
 - B) is less effective at higher speeds
 - C) generates a larger percentage of the total airplane deceleration on wet or slippery runways
 - D) is extremely effective, particularly on dry runways

Answer: C (Section 2.3.5.4)

- 26) Use of a clearway for takeoff results in _____ .
- A) a lower V_1 speed and increased maximum weight
 - B) a lower V_1 speed and decreased maximum weight
 - C) a higher V_1 speed and increased maximum weight
 - D) a higher V_1 speed and decreased maximum weight

Answer: A (Section 2.3.5.5)

- 27) When using the Assumed Temperature Method for reducing takeoff thrust, _____ .
- A) V_{mcg} and V_{mca} are reduced to correspond to the takeoff thrust being used
 - B) with an engine failure at the associated V_1 speed, a 35 foot height above the end of the runway may not be attainable without increasing thrust to the actual maximum rated thrust
 - C) the actual true air speed is lower than it would be if the actual temperature were equal to the assumed temperature
 - D) the actual true airspeed is higher than it would be if the actual temperature were equal to the assumed temperature

Answer: C (Section 2.3.5.7)

- 28) Which of the following is not a correct guideline for crews related to eliminating RTO overrun incidents?
- A) Do not initiate a stop after V_1 unless you suspect that a tire has failed or a catastrophic engine failure has occurred.
 - B) Don't change your mind, if you have begun an RTO, stop. If you have passed V_1 , go, unless the pilot has reason to conclude that the airplane is unsafe or unable to fly.
 - C) Both pilots must be sure to position the seat and rudder pedals so that maximum brake pressure can be applied.
 - D) Use maximum effort brake application.

Answer: A (Section 2.3.6.10)

- 29) Minimum takeoff distance can be achieved by _____ .
- A) sacrificing some runway line-up distance, so that thrust can be advanced for takeoff during the turn onto the runway
 - B) minimizing runway line-up distance by a sharper turn to line-up and setting takeoff power prior to releasing the brakes
 - C) slowly advancing thrust while rolling down the runway before engaging the autothrottle
 - D) line-up distance and setting takeoff thrust have minimal impact on takeoff distance

Answer: B (Section 2.3.6.3)

- 30) If you use manual braking for a rejected takeoff, _____ .
- A) pump the brakes to minimize skidding
 - B) maintain full brake pedal force
 - C) release braking when reverse thrust is applied

Answer: B (Section 2.3.6.5)

- 31) During a rejected takeoff from V_1 , a good technique is to use maximum braking and full reverse thrust _____ .
- A) until the airplane comes to a complete stop
 - B) until below 60 knots, then decrease reverse thrust to reduce the likelihood of compressor stalls
 - C) until the crew judges the remaining runway is sufficient for stopping with less than maximum effort
 - D) at high speeds, reducing braking at lower speeds to prevent fuse plugs from melting, since reverse thrust will further decrease stopping distance

Answer: A (Section 2.3.6.5)

- 32) For an RTO with anti-skid inoperative _____ .
- A) the RTO procedure is unchanged
 - B) brakes should be applied immediately after reducing power to idle
 - C) brakes should be applied after the speedbrake is raised
 - D) full brake pressure should only be applied at high speeds

Answer: C (Section 2.3.6.6)

- 33) On the average, RTO's performed with RTO autobrakes armed result in _____ runway distance remaining after a stop than do RTO's performed using manual braking only.
- A) more
 - B) less
 - C) the same

Answer: A (Section 2.3.6.7)

- 34) The Go/No Go decision must be made by _____ .
- A) the chief pilot and training staff
 - B) the crew flying
 - C) airline policies and guidelines
 - D) developing correct regulations

Answer: B (Section 2.3.6.10)

Summary of Answers

- 1. B
- 2. A
- 3. D
- 4. C
- 5. B
- 6. A
- 7. C
- 8. A
- 9. A
- 10. C
- 11. B
- 12. D
- 13. A
- 14. A
- 15. B
- 16. D
- 17. B
- 18. B
- 19. D
- 20. B
- 21. B
- 22. B
- 23. D
- 24. D
- 25. C
- 26. A
- 27. C
- 28. A
- 29. B
- 30. B
- 31. A
- 32. C
- 33. A
- 34. B

(This Page intentionally left blank)

Takeoff Safety Briefing

3-C

Takeoff Safety Briefing - A paper copy of view foils with descriptive words for each one that can be used for a classroom presentation is contained in this Appendix. The briefing supports a classroom discussion of the Pilot Guide and/or the optional video.

(This page intentionally left blank)

Simulator Exercises

3-D

The data in this appendix is supplied as a reference for an operator's training department. The example simulator training exercises are for specific airplane models and should be modified by operators to fit their particular syllabus and training devices to optimize learning. Any or all of the exercises may be combined into a simulator training syllabus as described in Section 3.2.2 of the basic training aid document. The General Description section for each exercise explains which for the initial conditions is of particular importance.

The Simulator Exercise data supplied to operators by the various manufacturers should be retained in this appendix as follows:

Table of Contents

Manufacturer	Page
Airbus Industries Airplanes	3-D.ABL.1
Boeing Airplanes	3-D.TBC.1
McDonnell Douglas Airplanes	3-D.MDC.1
Other Manufacturers Airplanes	3-D.OTH.1

The data contained in this appendix is provided for training purposes only and should not be used for any other purpose. Each manufacturer assumes responsibility only for the data which applies to their specific airplane models. Questions regarding any information presented in this appendix should be addressed to the responsible manufacturer

(This page intentionally left blank)

Rejected Takeoff and the Go/No Go Decision

To view .mpg video you must first have *Media Player* (PC) or *Movie Player* (Mac) loaded onto your computer.

PC users: Once loaded, open the program and then with 'file open' you will be able to view the video.

Macintosh Users: You will need to copy the .mpg video file to your harddrive, then open it through *Movie Player*. It will ask you to 'convert' the file instead of 'open' it (this process converts the .mpg to a *Quicktime* format). Your final step is to click the 'play' button at the lower left corner of the image.

Takeoff Safety Video Script

Rejected Takeoff and the Go/No Go Decision

Video Program (optional) - *Rejected Takeoff and the Go/No Go Decision*, is intended for use in an academic program in conjunction with Section 2, the Pilot Guide. Although the video is specifically designed to be used in a pilot briefing scenario, it can also be used to heighten the takeoff safety awareness of all people in an airline who are involved in areas which may contribute to the pilot needing to make a Go/No Go decision.

Those operators ordering the optional video will also receive a copy of the script, which can be retained in this appendix for reference.

The data in this appendix is provided for training purposes only and should not be used for any other purpose.

(This page intentionally left blank)

4

Takeoff Safety - Background Data

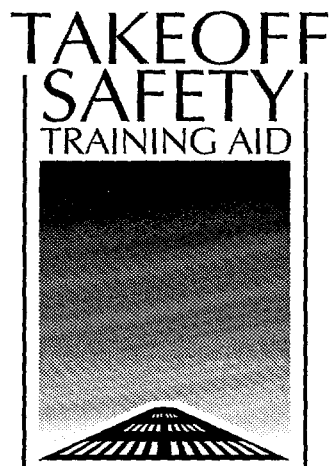

Takeoff Safety Background Data

Table of Contents

4

Section	Page
4.0	Introduction 4.1
4.1	Objectives 4.1
4.2	“Successful versus unsuccessful” Go/No Go decisions 4.2
4.2.1	An inservice perspective on Go/No Go decisions 4.2
4.2.2.	“Successful” Go/No Go decisions 4.3
4.2.3.	RTO overrun accidents and incidents 4.5
4.2.4.	Statistics 4.6
4.2.5	Lessons learned 4.8
4.3	Decisions and Procedures -- What every pilot should know 4.9
4.3.1	The takeoff rules -- the source of the data 4.9
4.3.1.1	The “FAR” takeoff field length 4.10
4.3.1.2	V ₁ speed defined 4.11
4.3.1.3	Balanced Field defined 4.12
4.3.1.4	Other rules affecting takeoff field length 4.13
4.3.2	Transition to the stopping configuration 4.13
4.3.2.1	Flight test transitions 4.13
4.3.2.2	Airplane Flight Manual transition times 4.14
4.3.3	Comparing the "Stop" and "Go" Margins 4.15
4.3.3.1	The "Stop" margins 4.16
4.3.3.2	The “Go” option 4.17
4.3.4	Operational takeoff calculations 4.19
4.3.4.1	The field length limit weight 4.19
4.3.4.2	Actual weight less than limit weight 4.19
4.3.5	Factors that affect takeoff and RTO performance 4.21
4.3.5.1	Runway surface condition 4.22
4.3.5.1.1	Hydroplaning 4.23
4.3.5.1.2	The final stop 4.24
4.3.5.2	Atmospheric conditions 4.24
4.3.5.3	Airplane configuration 4.25
4.3.5.3.1	Flaps 4.25
4.3.5.3.2	Engine bleed air 4.25
4.3.5.3.3	Missing or inoperative equipment 4.25
4.3.5.3.4	Wheels, tires, and brakes 4.27
4.3.5.3.5	Worn brakes 4.30
4.3.5.3.6	Residual brake energy 4.31
4.3.5.3.7	Speedbrake effect on wheel braking performance 4.31
4.3.5.3.8	Carbon and Steel brake differences 4.33
4.3.5.3.9	High brake energy RTO's 4.35

Takeoff Safety Background Data

Table of Contents (continued)

Section	Page
4.3.5	Factors that affect takeoff performance (continued)
4.3.5.4	Reverse thrust effects4.36
4.3.5.5	Runway parameters4.37
4.3.5.6	Lineup Distance Accountability4.38
4.3.5.7	Takeoffs using reduced thrust4.40
4.3.5.8	Takeoff data the pilot sees4.42
4.3.6	Increasing the RTO safety margins4.42
4.3.6.1	Runway surface condition4.42
4.3.6.2	Flap selection4.43
4.3.6.3	Runway lineup4.44
4.3.6.4	Setting takeoff thrust4.44
4.3.6.5	Manual braking techniques4.45
4.3.6.6	Antiskid inoperative braking techniques4.46
4.3.6.7	RTO Autobrakes4.46
4.3.6.8	Reduced V_1 Techniques4.47
4.3.6.9	The V_1 call4.50
4.3.6.10	Crew preparedness4.50
4.4	Crew Resource Management (CRM)4.51
4.4.1	CRM and the RTO4.51
4.4.2	The takeoff briefing4.51
4.4.3	Callouts4.53
4.4.4	The use of all crew members4.53
4.4.5	Summary4.53
Appendix 4-A	NTSB Special Investigation Report SIR -90/02
Appendix 4-B	RTO Accident/Incident List 1959 to 1990
Appendix 4-C	Other Takeoff Rules
Appendix 4-D	Reverse Thrust Effectiveness
Appendix 4-E	Takeoff Safety Training Aid Human Performance Study
Appendix 4-F	Airplane Flight Manual Transition Time Details
Appendix 4-G	Brake Pedal Force Data
Appendix 4-H	Reduced Thrust and Reduced V_1 Examples
Appendix 4-I	Lineup Distance Charts
Appendix 4-J	The Effect of Procedural Variations On Stopping Distance

Takeoff Safety - Background Data

4

4.0 Introduction

The rejected takeoff (RTO) is a maneuver performed at any time during the takeoff roll if the flight crew determines that the takeoff should not be continued. A review of the available data over the history of western built transport jet operations shows that approximately one in 3000 takeoffs has been rejected. Of these RTO's about one in 1000 was unsuccessful, resulting in an overrun accident or incident.¹ That is an accident/incident rate of one per 3,000,000 takeoff attempts.

The National Transportation Safety Board (NTSB), in a report on RTO overruns,² stated that historical evidence from two decades of RTO-related accidents "suggests that pilots faced with unusual or unique situations may perform high-speed RTO's unnecessarily or may perform them improperly." It is the goal of this Training Aid to reduce the number of RTO related accidents and incidents by improving the pilot's decision making and associated procedure accomplishment through increased knowledge and awareness of the related factors..

This section provides a thorough review of aspects of the takeoff that affect the Go/No Go decision. It reviews standard operating practices some airlines have adopted to maximize RTO stopping margins. It also reviews training practices that prepare crews to make sound Go/No Go decisions while using effective RTO techniques when an RTO is necessary.

4.1 Objectives

The objective is to reduce the number of RTO accidents and incidents while preserving the excellent record of takeoffs safely continued. Flight crews play a significant role in accomplishing this objective. The RTO begins with a decision by the crew to reject the takeoff and the crew will be responsible for the result. The airline's responsibility is to establish good standard operating procedures and provide the best possible training. The flight crew's responsibility is to correctly analyze all the data they receive prior to and during the takeoff roll and perform the "best" procedure for the circumstances.

The material in this section is intended to be a resource for those responsible for policy, procedures and training standards. It can also be used by training department personnel in the development of classroom material and as a resource for answering questions raised in the training process. It is recognized that there is more than one way for an airline to operate safely, therefore this section may not be appropriate for direct release to line pilots due to the requirements of operators to maintain standardization in the cockpit. The underlying message of this section for flight crew members is: be familiar with your airplane's basic performance characteristics and the margins associated with either continuing or rejecting a takeoff. Know the procedures that will be used for either option, and be prepared to perform them promptly.

Some of the Appendices³ to this section contain data related to specific airplane models. This data is prepared and delivered by each airplane manufacturer and is the exclusive responsibility of that manufacturer.

¹ Following generally accepted conventions, in this document an accident is defined as an event which involves a fatality and/or serious airframe damage. An incident is defined as an event which results in serious damage to the airplane only, but no fatalities.

² Appendix 4-A, NTSB/SIR-90/02 Special Investigation Report—Runway Overruns Following High Speed Rejected Takeoffs, 27 February 1990.

³ Appendix 4-F through 4-J contain airplane model specific data.

4.2 "Successful Versus Unsuccessful" Go/No Go Decisions

Any Go/No Go decision can be considered "successful" if it does not result in injury or airplane damage. However, just because it was "successful" by this definition, it does not mean the action was the "best" that could have been taken. The purpose of this section is to point out some of the lessons that have been learned through the RTO experiences of airline crews over the past 30 years, and to recommend ways of avoiding similar experiences by the pilots of today's airline fleet.

4.2.1 An Inservice Perspective On Go/No Go Decisions

Modern jet transport services began in the early 1950's and significantly increased later that decade after introduction of the Boeing 707 and the Douglas DC-8. The western built jet transport fleet accumulated approximately

230 million takeoffs by the end of 1990. The projection for 1995 alone is nearly 18 million takeoffs. That's approximately 34 takeoffs every minute, every day!

Since no comprehensive fleet-wide records are available, it is difficult to identify the total number of RTO's that have occurred throughout the jet era. However, based on those events which have been documented, our best estimate is that one in 3000 takeoff attempts ends with an RTO. At this rate, there will be nearly 6000 RTO's during the year 1995. That means that every day in 1995, 16 flight crews will perform an RTO. Statistically, at the rate of one RTO per 3000 takeoffs, a pilot who flies short-haul routes and makes 80 departures per month, will experience one RTO every three years. At the opposite extreme, the long-haul pilot making only eight departures per month will be faced with only one RTO every 30 years.

The probability that a pilot will ever be required to perform an RTO from high speed is even less, as is shown in Figure 2.

Takeoffs, RTOs, and Overruns

Figure 1
Takeoffs, RTO's and
Overrun Statistics

	Through 1990	Projected 1995
Takeoffs	230,000,000	18,000,000
RTOs (est.)	76,000	6,000
RTO Overrun Accidents/Incidents	74	6

- 1 RTO per 3,000 takeoffs
- 1 RTO overrun accident/incident per 3,000,000 takeoffs

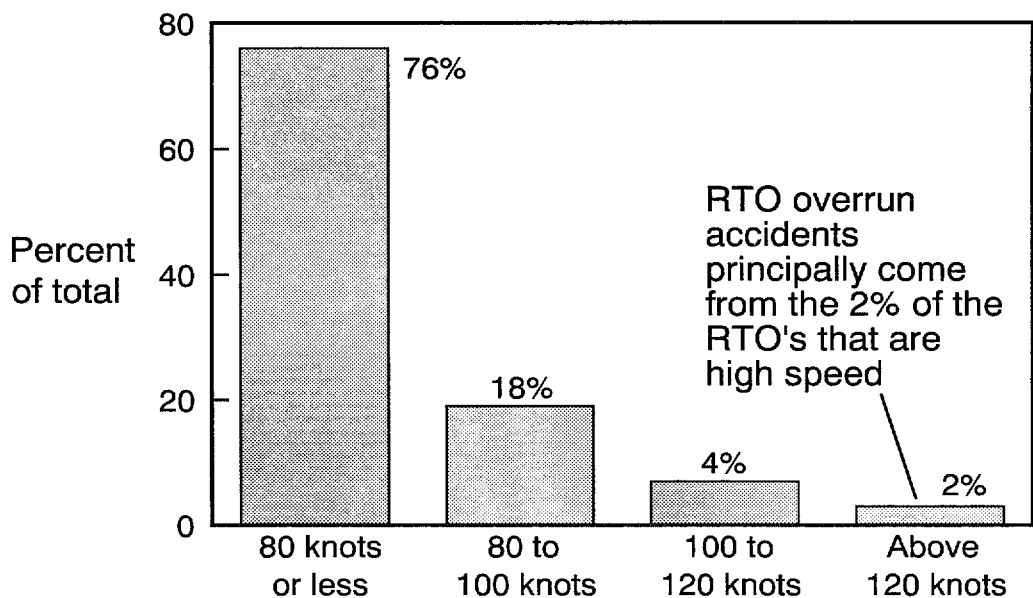

Figure 2
Distribution of
RTO Initiation
Speeds

Available data indicates that over 75% of all RTO's are initiated at speeds of 80 knots or less. These RTO's almost never result in an accident. Inherently, low speed RTO's are safer and less demanding than high speed RTO's. At the other extreme, about 2% of the RTO's are initiated at speeds above 120 knots. Overrun accidents and incidents that occur principally stem from these high speed events.

What should all these statistics tell a pilot? First, RTO's are not a very common event. This speaks well of equipment reliability and the preparation that goes into operating jet transport airplanes. Both are, no doubt, due in large part to the certification and operational standards developed by the aviation community over the thirty plus years of operation. Second, and more important, the infrequency of RTO events may lead to complacency about maintaining sharp decision-making skills and procedural effectiveness. In spite of the equipment reliability, **every pilot must be prepared to make the correct Go/No Go decision on every takeoff — just in case.**

4.2.2 "Successful" Go/No Go Decisions

As was mentioned at the beginning of Section 4.2, there is more to a "good" Go/No Go decision than the fact that it may not have resulted in any injury or aircraft damage. The following examples illustrate a variety of situations that have been encountered in the past, some of which would fit the description of a "good" decision, and some which are, at least, "questionable".

Listed at the beginning of each of the following examples, is the primary cause or cue which prompted the crew to reject the takeoff:

1. **Takeoff Warning Horn:** The takeoff warning horn sounded as the takeoff roll commenced. The takeoff was rejected at 5 knots. The aircraft was taxied off the active runway where the captain discovered the stabilizer trim was set at the aft end of the green band. The stabilizer was reset and a second takeoff was completed without further difficulty.

2. **Takeoff Warning Horn:** The takeoff was rejected at 90 knots when the takeoff warning horn sounded. The crew found the speed brake lever slightly out of the detent. A normal takeoff was made following a delay for brake cooling.

3. **Engine Power Setting:** The throttles were advanced and N_1 increased to slightly over 95%. N_1 eventually stabilized at 94.8% N_1 . The target N_1 from the FMC Takeoff Page was 96.8% N_1 . The throttles were then moved to the firewall but the N_1 stayed at 94.8%. The takeoff was rejected due to low N_1 at 80 knots.

4. **Compressor Stall:** The takeoff was rejected from 155 knots due to a bird strike and subsequent compressor stall on the number three engine. Most of the tires subsequently deflated due to melted fuse plugs.

5. **Nose Gear Shimmy:** The crew rejected the takeoff after experiencing a nose landing gear shimmy. Airspeed at the time was approximately V_1-10 knots. All four main gear tires subsequently blew during the stop, and fires at the number 3 and 4 tires were extinguished by the fire department.

6. **Blown Tire:** The takeoff was rejected at 140 knots due to a blown number 3 main gear tire. Number 4 tire blew turning onto the taxiway causing the loss of both A and B hydraulic systems as well as major damage to flaps, spar, and spoilers.

These examples demonstrate the diversity of rejected takeoff causes. All of these RTO's were "successful", but some situations came very close to ending differently. By contrast, the large number of takeoffs that are successfully continued with indications of air-

plane system problems such as caution lights that illuminate at high speed or tires that fail near V_1 , are rarely ever reported outside the airline's own information system. They may result in diversions and delays but the landings are normally uneventful, and can be completed using standard procedures.

This should not be construed as a blanket recommendation to "Go, no matter what." The goal of this training aid is to eliminate RTO accidents by reducing the number of improper stop decisions that are made, and to ensure that the correct procedures are accomplished when an RTO is necessary. It is recognized that the kind of situations that occur in line operations are not always the simple problem that the pilot was exposed to in training. Inevitably, the resolution of some situations will only be possible through the good judgment and discretion of the pilot, as is exemplified in the following takeoff event:

After selecting EPR mode to set takeoff thrust, the right thrust lever stuck at 1.21 EPR, while the left thrust lever moved to the target EPR of 1.34. The captain tried to reject the takeoff but the right thrust lever could not be moved to idle. Because the light weight aircraft was accelerating very rapidly, the Captain advanced the thrust on the left engine and continued the takeoff. The right engine was subsequently shut down during the approach, and the flight was concluded with an uneventful single-engine landing.

The failure that this crew experienced was not a standard training scenario. Nor is it included here to encourage pilots to change their mind in the middle of an RTO procedure. It is simply an acknowledgment of the kind of real world decision making situations that pilots face. It is perhaps more typical of the good judgements that airline crews regularly make, but the world rarely hears about.

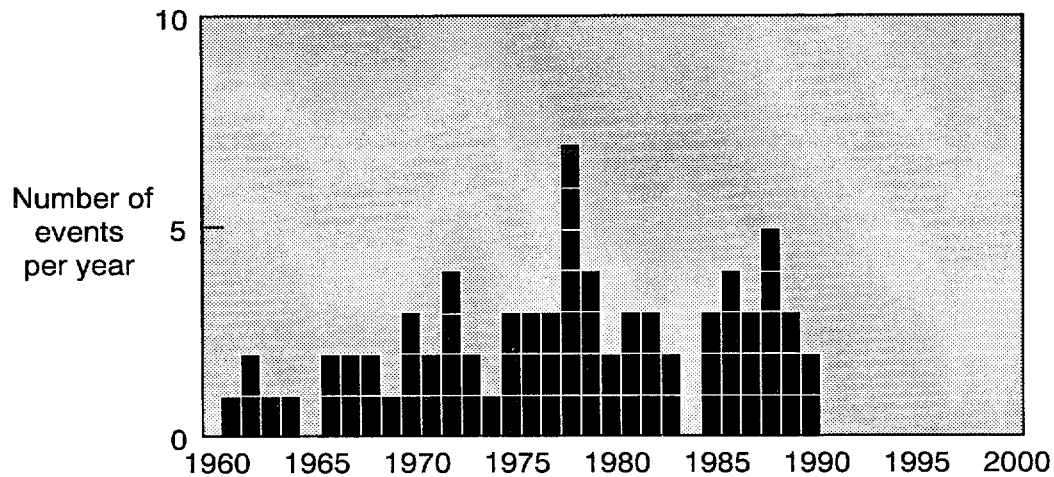

Figure 3
74 RTO Overrun
Accidents/Incidents
1959-1990

4.2.3 RTO Overrun Accidents and Incidents

The one-in-one-thousand RTO's that became accidents or serious incidents are the ones that we must strive to prevent. As shown in figure 3, at the end of 1990, records show 46 inservice RTO overrun accidents for the western built jet transport fleet. These 46 accidents caused more than 400 fatalities. An additional 28 serious incidents have been identified which likely would have been accidents if the runway overrun areas had been less forgiving. The following are brief accounts of four actual accidents. They are real events. Hopefully, they will not be repeated.

ACCIDENT: At 154 knots, four knots after V_1 , the copilot's side window opened, and the takeoff was rejected. The aircraft overran, hitting a blast fence, tearing open the left wing and catching fire.

ACCIDENT: The takeoff was rejected by the captain when the first officer had difficulty maintaining runway tracking along the 7000 foot wet runway. Initial reports indicate that the airplane slowly accelerated

at the start of the takeoff roll due to a delay in setting takeoff thrust. The cockpit voice recorder (CVR) readout indicates there were no speed callouts made during the takeoff attempt. The reject speed was 5 knots above V_1 . The transition to stopping was slower than expected. This was to have been the last flight in a long day for the crew. Both pilots were relatively inexperienced in their respective positions. The captain had about 140 hours as a captain in this airplane type and the first officer was conducting his first non-supervised line takeoff in this airplane type. The airplane was destroyed when it overran the end of the runway and broke apart against piers which extend off the end of the runway into the river. There were two fatalities. Subsequent investigation revealed that the rudder was trimmed full left prior to the takeoff attempt.

ACCIDENT: A flock of sea gulls was encountered "very near V_1 ." The airplane reportedly had begun to rotate. The number one engine surged and flamed out and the takeoff was rejected. The airplane overran the end of the wet 6000 foot runway despite a good RTO effort.

ACCIDENT: At 120 knots, the flight crew noted the onset of a vibration. When the vibration increased, the captain elected to reject and assumed control. Four to eight seconds elapsed between the point where the vibration was first noted and when the RTO was initiated (just after V_1). Subsequent investigation showed two tires had failed. The maximum speed reached was 158 knots. The airplane overran the end of the runway at a speed of 35 knots and finally stopped with the nose in a swamp. The airplane was destroyed.

These four cases are typical of the 74 reported accidents and incidents. A list of the 74 cases is included in Appendix 4-B as a reference.

4.2.4 Statistics

Studies of the previously mentioned 74 accidents/incidents have revealed some interesting statistics, as shown in Figure 4:

- Fifty-eight percent were initiated at speeds in excess of V_1 .
- Approximately one-third were reported as having occurred on runways that were wet or contaminated with snow or ice.

Both of these issues will be thoroughly discussed in subsequent sections.

Figure 4
Major factors
in past RTO
accidents and
incidents

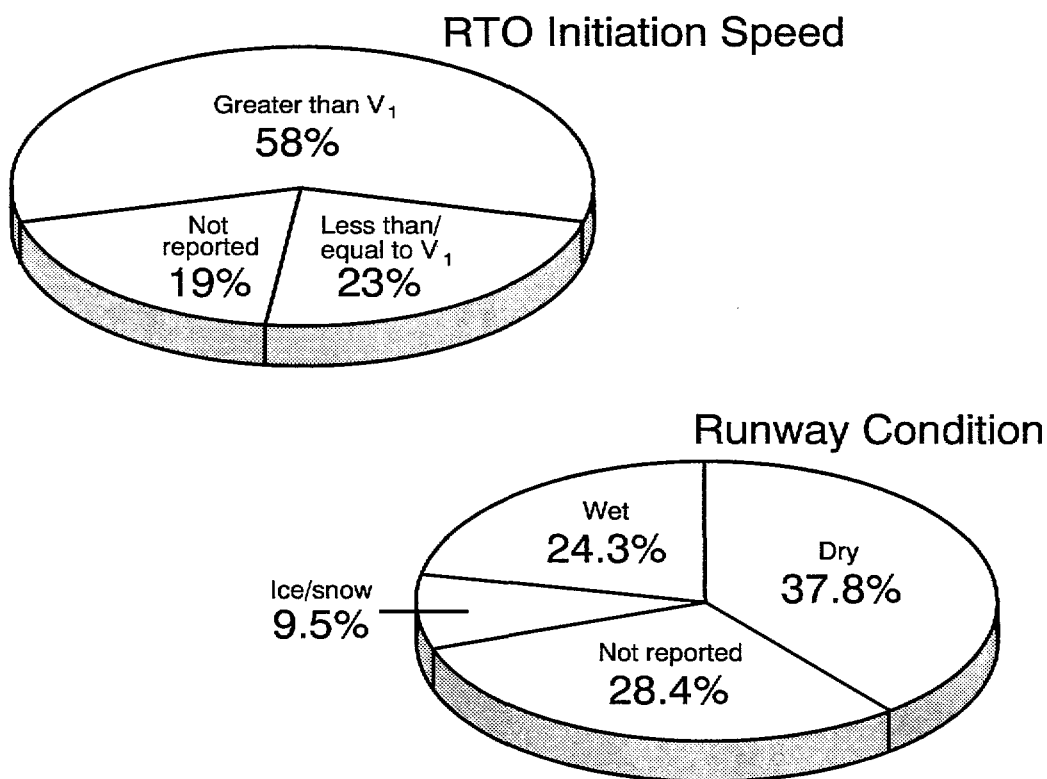

An additional, vitally interesting statistic that was observed when the accident records involving Go/No Go decisions were reviewed, was that virtually no revenue flight was found where a "Go" decision was made and the airplane was incapable of continuing the takeoff. Regardless of the ability to safely continue the takeoff, as will be seen in Section 4.3, virtually any takeoff can be "successfully" rejected, if the reject is initiated early enough and is conducted properly. There is more to the Go/NoGo decision than "Stop before V_1 " and "Go after V_1 ." The statistics of the past three decades show that a number of jet transports have experienced circumstances near V_1 that rendered the airplane incapable of being stopped on the runway remaining. It also must be recognized, that catastrophic situations could occur which render the airplane incapable of flight.

Reasons why the 74 "unsuccessful" RTO's were initiated are also of interest. As shown in Figure 5, approximately one-fourth were initiated because of engine failures or engine indication warnings. The remaining seventy-six percent were initiated for a variety of reasons which included tire failures, procedural error, malfunction indication or lights, noises and vibrations, directional control difficulties and unbalanced loading situations where the airplane failed to rotate. Some of the events contained multiple factors such as an RTO on a contaminated runway following an engine failure at a speed in excess of V_1 . The fact that the majority of the accidents and incidents occurred on airplanes that had full thrust available should figure heavily in future Go/No Go training.

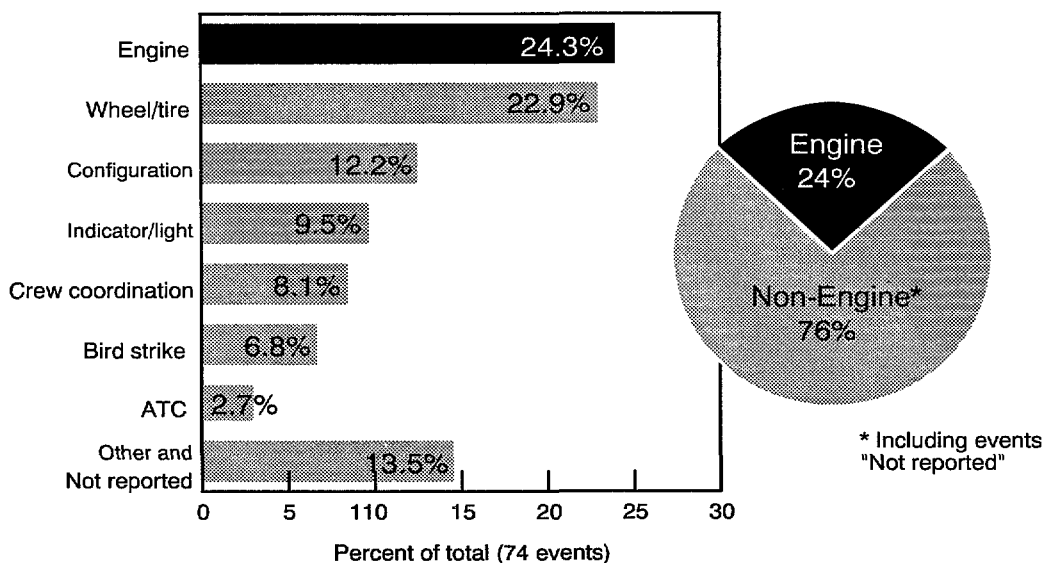

Figure 5
Reasons for
Initiating the 74
RTO Accidents

4.2.5 Lessons Learned

Several lessons can be learned from these RTO accidents. First, the crew must always be prepared to make the Go/No Go decision prior to the airplane reaching V_1 speed. As will be shown in subsequent sections, there may not be enough runway left to successfully stop the airplane if the reject is initiated after V_1 . Second, in order to eliminate unnecessary RTO's, the crew must differentiate between situations that are detrimental to a safe takeoff, and those that are not. Third, the crew must be prepared to act as a well-coordinated team. A good summarizing statement of these lessons is, **as speed approaches V_1 , the successful completion of an RTO becomes increasingly more difficult.**

A fourth and final lesson learned from the past 30 years of RTO history is illustrated in Figure 6. Analysis of the available data suggests that of the 74 RTO accidents and incidents, approximately 80% were potentially avoidable through appropriate operational practices. These potentially avoidable accidents can be divided into three categories. Roughly 9% of the RTO accidents of the past were the result of improper preflight planning. Some of these instances were caused by loading errors and others by incorrect preflight procedures. About 16% of the accidents and incidents could be attributed to incorrect pilot techniques or procedures in the stopping effort. Delayed application of the brakes, failure to deploy the speedbrakes, and the failure to make a maximum effort stop until late in the RTO were the chief characteristics of this category.

Review of the data from the 74 RTO accidents and incidents suggests that in approximately 55% of the events, the airplane was capable of continuing the takeoff and either landing at the departure airport or diverting to an alternate. In other words, the decision to reject the takeoff appears to have been improper. It is not possible, however, to predict with total certainty what would have happened in every event if the takeoff had been continued. Nor is it possible for the analyst of the accident data to visualize the events leading up to a particular accident "through the eyes of the crew", including all the other factors that were vying for their attention at the moment when the "proper" decision could have been made. It is not very difficult to imagine a set of circumstances where the only logical thing for the pilot to do is to reject the takeoff. Encountering a large flock of birds at rotation speed, which then produces loss of thrust on both engines of a two-engine airplane, is a clear example.

Although these are all valid points, debating them here will not move us noticeably closer to the goal of reducing the RTO accident rate. Several industry groups have recently studied this problem. Their conclusions and recommendations agree surprisingly well. The areas identified as most in need of attention are decision making and proficiency in correctly performing the appropriate procedures. These are the same areas highlighted in Figure 6. It would appear then, that an opportunity exists to significantly reduce the number of RTO accidents in the future by improving the pilot's decision making capability, and the procedure accomplishment through better training.

Figure 6
80% of the RTO
accidents and
incidents were
avoidable

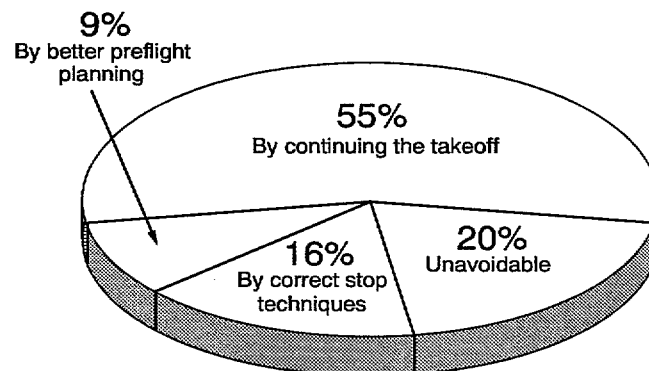

4.3 Decisions and Procedures - - What Every Pilot Should Know

There are many things that may ultimately affect the outcome of a Go/No Go decision. The goal of the *Takeoff Safety Training Aid* is reduce the number of RTO related accidents and incidents by improving the pilot's decision making and associated procedure accomplishment through increased knowledge and awareness of the related factors. This section discusses the rules that define takeoff performance limited weights and the margins that exist when the actual takeoff weight of the airplane is less than the limit weight. The effect of runway surface condition, atmospheric conditions, and airplane configuration variables on Go/No Go performance are discussed, as well as what the pilot can do to make the best use of any excess available runway.

Although the information contained in this section has been reviewed by many major airframe manufacturers and airlines, the incorporation of any of the recommendations made in this section are subject to the approval of each operator's management.

4.3.1 The Takeoff Rules - - The Source of the Data

Let's look at the takeoff from a distance. It may appear that basic common sense would assure a safe conclusion. Common sense will go a long way, but skill and preparedness are necessary also. It is important that all pilots understand the takeoff field length/weight limit criteria and the margins these criteria provide. The rules, in effect, define the window within which the airplane and the pilot must perform in order to achieve the expected results. Misunderstanding the rules and their application to the operational situation could contribute to an incorrect Go/No Go decision.

The U.S. Federal Aviation Regulations (FAR's) have continually been refined so that the details of the rules that are applied to one airplane model may differ from another. However, these differences are minor and have no effect on the basic actions required of the flight crew during the takeoff. Some differences, as discussed in Section 4.3.1.4 and in Appendix 4-C, also occur between FAA certified performance levels and the criteria applied by other regulatory agencies. It is worth noting here, that proposed rule changes currently under consideration by the various regulatory agencies, will probably eliminate any significant differences in the very near future. In general, it is more important for the crew to understand the basic principles rather than the technical variations in certification policies. However, some significant differences exist between commercial airplane certification rules and U.S. military rules which can foster misunderstanding by pilots with a background of military flying. These differences are also discussed in Appendix 4-C.

The most recent revision to the FAR's (Amendment 25-42) has only been applied to a limited number of airplanes at this time, and therefore is not discussed in this section. As of July, 1992, there are revisions under consideration to both the FAR's and the JAR's. These revisions are understood to be intended to "harmonize" the two sets of rules (i.e. make them equivalent). The subject areas being revised include the accelerate-stop distance criteria, wet runway accountability, lineup distance accountability, and the effects of worn brakes. However, they are not yet finalized and are therefore not, in general, discussed in this document.

4.3.1.1 The "FAR" Takeoff Field Length

The "FAR" Takeoff Field Length determined from the FAA approved Airplane Flight Manual (AFM) considers the most limiting of each of the following three criteria:

- 1) All-Engine Go Distance: 115% of the actual distance required to accelerate, liftoff and reach a point 35 feet above the runway with all engines operating (Figure 7).
- 2) Engine-Out Accelerate-Go Distance: The distance required to accelerate with all engines operating, have one engine fail at V_{EF} , at least one second before V_1 , continue the takeoff, liftoff and reach a point 35 feet above the runway surface at V_2 speed (Figure 8).
- 3) Engine-Out Accelerate-Stop Distance: The distance required to accelerate with all engines operating, have an engine fail at V_{EF} at least one second before V_1 , recognize the failure, reconfigure for stop-

ping and bring the airplane to a stop using maximum wheel braking with the speedbrakes extended. Reverse thrust is not used to determine the FAR accelerate-stop distance (Figure 9).

The FAR criteria provide accountability for wind, runway slope, clearway and stopway. FAA approved takeoff data are based on the performance demonstrated on a smooth, dry runway. Separate advisory data for wet or contaminated runway conditions are published in the manufacturer's operational documents. These documents are used by many operators to derive wet or contaminated runway takeoff adjustments.

Other criteria define the performance weight limits for takeoff climb, obstacle clearance, tire speeds and maximum brake energy capability. Any of these other criteria can be the limiting factor which determines the maximum dispatch weight. However, the Field Length Limit Weight and the amount of runway remaining at V_1 will be the primary focus of our discussion here since they more directly relate to preventing RTO overruns.

Figure 7
All-engine go
distance

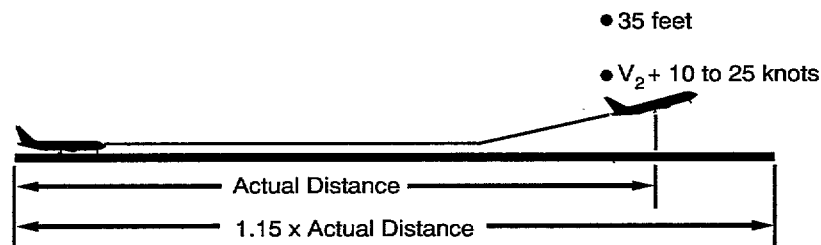

Figure 8
Engine-out
accelerate-go
distance

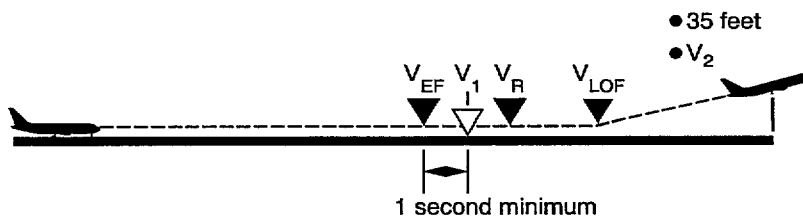
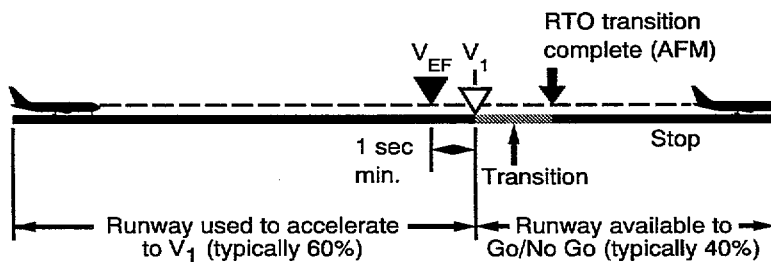
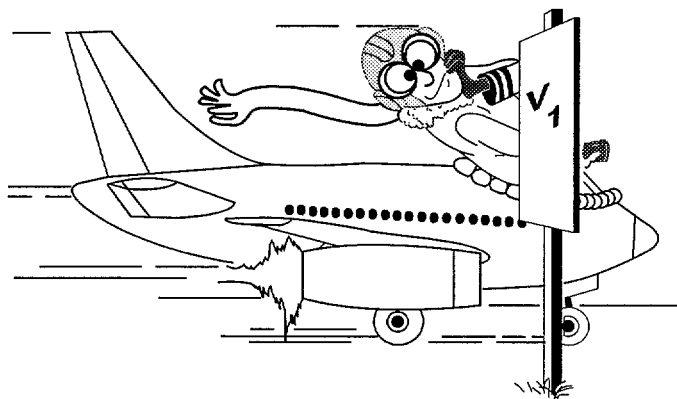

Figure 9
Engine-out
accelerate-stop
distance



4.3.1.2 V_1 Speed Defined



What is the proper operational meaning of the key parameter “ V_1 speed” with regard to the Go/No Go criteria? This is not such an easy question since the term “ V_1 speed” has been redefined several times since commercial jet operations began more than 30 years ago and there is possible ambiguity in the interpretation of the words used to define V_1 .

Paragraph 25.107 of the FAA Regulations defines the relationship of the takeoff speeds as published in the Airplane Flight Manual, to various speeds determined in the certification testing of the airplane. Although the terms engine failure speed, decision speed, recognizes, and reacts are all within this “official” definition, for our purposes here, the most important statement within this “official” definition is that V_1 is determined from “...the pilot’s application of the first retarding means during the accelerate-stop tests.”

One common and misleading way to think of V_1 is to say “ V_1 is the decision speed.” This is misleading because V_1 is not the point to begin making the operational Go/No Go decision. **The decision must have been made by the time the airplane reaches V_1 or the pilot will not have initiated the RTO procedure at V_1 .** Therefore, by definition, the airplane will be traveling at a speed higher than V_1 when stopping action is initiated, and if the airplane is at a Field Length Limit Weight, an overrun is virtually assured.

Another commonly held misconception: “ V_1 is the engine failure recognition speed”, suggests that the decision to reject the takeoff following engine failure recognition may begin as late as V_1 . Again, the airplane will have accelerated to a speed higher than V_1 before stopping action is initiated. The certified accelerate-stop distance calculation is based on an engine failure at least one second prior to V_1 . This standard time allowance³ has been established to allow the line pilot to recognize an engine failure and begin the subsequent sequence of stopping actions.

In an operational Field Length Limited context, the correct definition of V_1 consists of two separate concepts:

First, with respect to the “No-Go” criteria, **“ V_1 is the maximum speed at which the rejected takeoff maneuver can be initiated and the airplane stopped within the remaining field length under the conditions and procedures defined in the FAR’s.” It is the latest point in the takeoff roll where a stop can be initiated.**

Second, with respect to the “Go” criteria, **V_1 is also the earliest point from which an engine out takeoff can be continued and the airplane attain a screen height of 35 feet at the end of the runway.** This aspect of V_1 is discussed in Section 4.3.3.

³ The time interval between V_{EF} and V_1 is the longer of the flight test demonstrated time or one second. Therefore, in determining the scheduled accelerate-stop performance, one second is the minimum time that will exist between the engine failure and the first pilot stopping action.

The Go/No Go decision must be made before reaching V_1 . A "No Go" decision after passing V_1 will not leave sufficient runway remaining to stop if the takeoff weight is equal to the Field Length Limit Weight. As will be discussed in Section 4.3.4.2, when the airplane actual weight is less than the Field Length Limit Weight, it is possible to calculate the actual maximum speed from which the takeoff could be successfully rejected. However, few operators use such takeoff data presentations. It is therefore recommended that pilots consider V_1 to be a limit speed: Do not attempt an RTO once the airplane has passed V_1 unless the pilot has reason to conclude the airplane is unsafe or unable to fly. This recommendation should prevail no matter what runway length appears to remain after V_1 .

4.3.1.3 Balanced Field Defined

The previous two sections established the general relationship between the takeoff performance regulations and V_1 speed. This section provides a closer examination of how the choice of V_1 actually affects the takeoff performance in specific situations.

Since it is generally easier to change the weight of an airplane than it is to change the length of a runway, consider the effect of V_1 on the allowable takeoff weight from a fixed runway length.

The Continued Takeoff - - After an engine failure during the takeoff roll, the airplane must continue to accelerate on the remaining engine(s), liftoff and reach V_2 speed at 35 feet.

The later in the takeoff roll that the engine fails, the heavier the airplane can be and still gain enough speed to meet this requirement. For the engine failure occurring one second prior to V_1 , the relationship of the allowable engine-out go takeoff weight to V_1 would be as shown by the "Continued Takeoff" line in Figure 10. The higher the V_1 , the heavier the takeoff weight allowed.

The Rejected Takeoff - - On the stop side of the equation, the V_1 /weight trade has the opposite trend. The lower the V_1 , or the earlier in the takeoff roll the stop is initiated, the heavier the airplane can be, as indicated by the "Rejected Takeoff" line in Figure 10.

The point at which the "Continued and Rejected Takeoff" lines intersect is of special interest. It defines what is called a "Balanced Field Limit" takeoff. The name "Balanced Field" refers to the fact that the accelerate-go performance required is exactly equal to (or "balances") the accelerate-stop performance required. From Figure 10 it can also be seen that at the "Balanced Field" point, the allowable Field Limit Takeoff Weight for the given runway is the maximum. The resulting unique value of V_1 is referred to as the "Balanced Field Limit V_1 Speed" and the associated takeoff weight is called the "Balanced Field Weight Limit." This is the V_1 speed that is typically given to flight crews in handbooks or charts, by onboard computer systems, or by dispatch.

The concept of a balanced field condition is revisited in Section 4.3.4 as it relates to operational takeoff situations.

Figure 10
Effect of V_1 speed on
takeoff weight (from
a fixed runway
length)

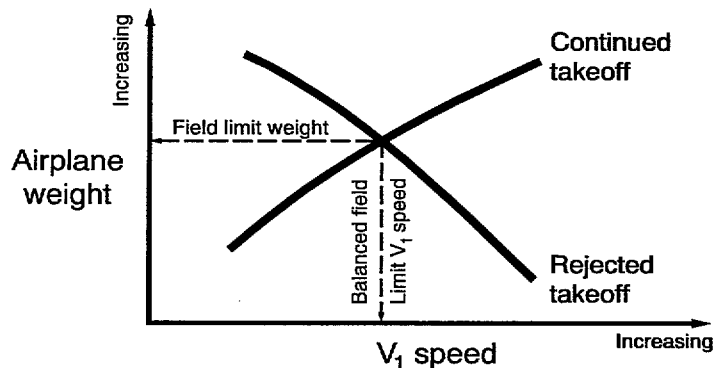

4.3.1.4 Other Rules Affecting Takeoff Field Length

Some regulatory authorities outside the United States have adopted takeoff rules different from the FAA. For the most part, the differences have minimal effect on takeoff performance and, as a consequence, do not impact the Go/No Go decision. Most significantly, however, some authorities require the effects of a wet runway to be included in the calculation of the maximum allowable takeoff weight. The FAA and several other regulatory agencies currently have similar wet runway requirements under review. The detail considerations of runway surface condition on takeoff safety are discussed in Section 4.3.5.1.

Since the Go/No Go decision made at a speed near V_1 must be essentially an instinctive reaction based on previous planning and training, a pilot's prior flying experience will play a significant role in the decision process. Ideally, it would be best if the training received on one airplane model was completely applicable when a pilot is transitioning to a different airplane. This ideal situation may be achievable over time at a given airline via thorough standardization, but the attainment of this goal may be hindered if the training program does not recognize some of the biases and preconceptions of the student. Typical areas of potential misunderstanding would be pilots who are hired from another airline; have flown previously under the regulations of a different country; or are transitioning to commercial aviation from a military background.

As an aid to the operator in developing a training program which adequately addresses these concerns, Appendix 4-C contains a discussion of the takeoff rules for other countries and for the U.S. military, as they relate to the Go/No Go decision. It is also intended as a place for operators to include any other regulatory definitions which they feel are pertinent to their particular pilot training program.

4.3.2 Transition to the Stopping Configuration

In establishing the certified accelerate-stop distance, the time required to reconfigure the airplane from the "Go" to the "Stop" mode is referred to as the "transition" segment. This action and the associated time of accomplishment includes applying maximum braking, simultaneously moving the thrust levers to idle and raising the speedbrakes. The transition time demonstrated by flight test pilots during the accelerate-stop testing is used to derive the transition segment times used in the AFM calculations. The relationship between the flight test demonstrated transition times and those finally used in the AFM is another frequently misunderstood area of RTO performance.

4.3.2.1 Flight Test Transitions

Several methods of certification testing that produce comparable results have been found to be acceptable. The following example illustrates the intent of these methods.

During certification testing, the airplane is accelerated to a pre-selected speed, one engine is "failed" by selecting fuel cut-off, and the pilot flying rejects the takeoff. In human factors circles, this is defined as a "simple task" because the test pilot knows in advance that an RTO will be performed. Exact measurements of the time taken by the pilot to apply the brakes, retard the thrust levers to idle, and to deploy the speedbrakes are recorded. Detailed measurements of engine parameters during spooldown are also made so that the thrust actually being generated can be accounted for in the calculation.

The manufacturer's test pilots, and pilots from the regulatory agency, each perform several rejected takeoff test runs. An average of the recorded data from at least six of these RTO's is then used to determine the "demonstrated"

transition times for applying the brakes, retarding the throttles to idle, and extending the speedbrakes. These three actions determine when the forces acting to accelerate (thrust) or decelerate (braking and drag) the airplane take place. It is the integration of these acceleration and deceleration forces that will ultimately determine the runway distance required.

The total flight test “demonstrated” transition time, initial brake application to speedbrakes up, is typically one second or less. However this is not the total transition time used to establish the certified accelerate-stop distances. The certification regulations require that additional time delays, sometimes referred to as “pads”, be included in the calculation of certified takeoff distances.

4.3.2.2 Airplane Flight Manual Transition Times

Although the line pilot must be prepared for an RTO during every takeoff, it is fairly likely that the event or failure prompting the Go/No Go decision will be much less clear-cut than an outright engine failure. It may therefore be unrealistic to expect the average line pilot to perform the transition in as little as one second in an operational environment. Human factors literature describes the line pilot’s job as a “complex task” since the pilot does not know when an RTO will occur. In consideration of this “complex task”, the flight test transition times are increased to calculate the certified

accelerate-stop distances specified in the AFM. **These additional time increments are not intended to allow extra time for making the “No Go” decision after passing V_1 . Their purpose is to allow sufficient time (and distance) for “the average pilot” to transition from the takeoff mode to the stopping mode⁴.**

The first adjustment is made to the time required to recognize the need to stop. During the RTO certification flight testing, the pilot knows that the engine will be failed, therefore, his reaction is predictably quick. To account for this, an engine failure recognition time of at least one second has been set as a standard for all jet transport certifications since the late 1960’s. V_1 is therefore, at least one second after the engine failure. During this recognition time segment, the airplane continues to accelerate with the operating engine(s) continuing to provide full forward thrust. The “failed” engine has begun to spool down, but it is still providing some forward thrust, adding to the airplane’s acceleration.

Over the years, the details of establishing the transition time segments after V_1 have varied slightly but the overall concept and the resulting transition distances have remained essentially the same. For early jet transport models, an additional one second was added to both the flight test demonstrated throttles-to-idle time and the speedbrakes-up time, as illustrated in Figure 11. The net result is that the flight test demonstrated recognition and transition time of approximately one second has been increased for the purpose of calculating the AFM transition distance.

Figure 11
Early Method of
Establishing AFM
Transition time

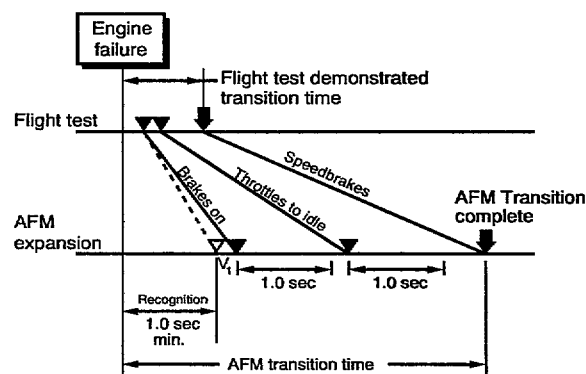

⁴The data in Appendix 4-J, *Takeoff Safety Training Aid Human Performance Study*, corroborate this statement

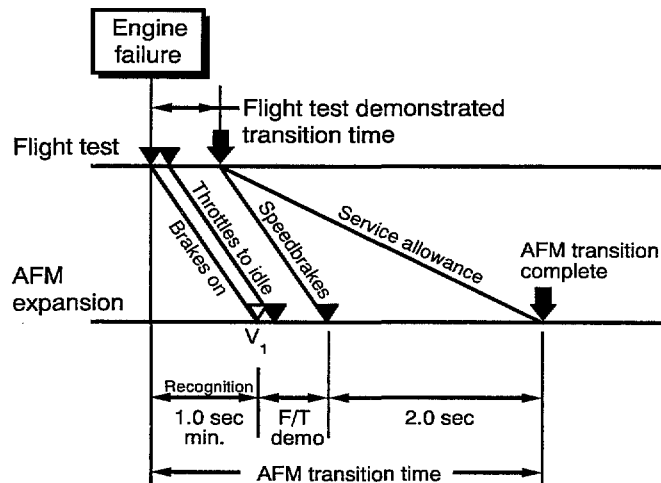

Figure 12
More recent method
of establishing
AFM transition
time

In more recent certification programs, the AFM calculation procedure was slightly different. An allowance equal to the distance traveled during two seconds at the speedbrakes-up speed was added to the actual total transition time demonstrated in the flight test to apply brakes, bring the thrust levers to idle and deploy the speedbrakes, as shown in Figure 12. To insure “consistent and repeatable results,” retardation forces resulting from brake application and speed brake deployment are not applied during this two second allowance time, i.e. no deceleration credit is taken. This two second distance allowance simplifies the transition distance calculation and accomplishes the same goal as the individual one second “pads” used for older models. Regardless of the method used, the accelerate-stop distance calculated for every takeoff from the AFM is typically 400 to 600 feet longer than the flight test accelerate-stop distance. Details of the certified transition times for specific airplane models is included in Appendix 4-F as a reference for the instructor.

These differences between the past and present methodology are not significant in so far as the operational accelerate-stop distance is concerned. **The key point is that the time/distance “pads” used in the AFM transition distance calculation are not intended to allow extra time to make the “No Go” decision.** Rather, the “pads” are meant to recognize that execut-

ing the “No Go” decision and its subsequent stopping action represent a human factors “complex task.” They provide an allowance that assures the pilot has adequate distance to get the airplane into the full stopping configuration, and stop the airplane on the runway.

Regardless of the airplane model, the transition, or reconfiguring of the airplane for a rejected takeoff, demands quick action by the crew to simultaneously initiate maximum braking, retard the thrust levers to idle and then quickly raise the speedbrakes.

4.3.3 Comparing the “Stop” and “Go” Margins

When performing a takeoff at a Field Length Limit Weight determined from the AFM, the pilot is assured that the airplane performance will, at the minimum, conform to the requirements of the FAR’s if the assumptions of the calculations are met. This means that following an engine failure at V_{EF} , the takeoff can be rejected at V_1 and the airplane stopped at the end of the runway, or if the takeoff is continued, a minimum height of 35 feet will be reached over the end of the runway.

This section discusses the inherent conservatism of these certified calculations, and the margins they provide beyond the required minimum performance.

Figure 13
 Overrun Speed
 for an RTO
 initiated after V_1

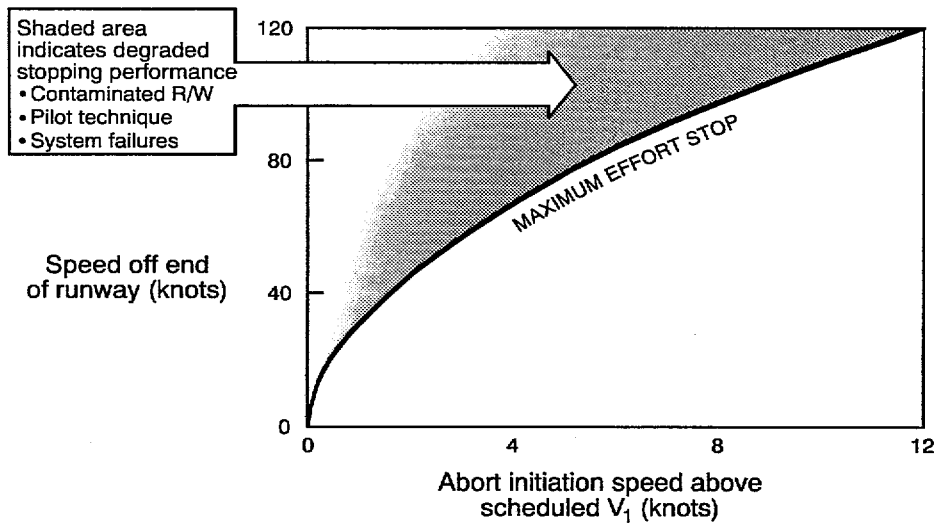

4.3.3.1 The "Stop" Margins

From the preceding discussion of the certification rules, it has been shown that at a Field Length Limit Weight condition, an RTO initiated at V_1 will result in the airplane coming to a stop at the end of the runway. This accelerate-stop distance calculation specifies a smooth, dry runway, an engine failure at V_{EF} , the pilot's initiation of the RTO at V_1 , and the completion of the transition within the time allotted in the AFM. If any of these basic assumptions are not satisfied, the actual accelerate-stop distance may exceed the AFM calculated distance, and an overrun will result.

The most significant factor in these assumptions is the initiation of the RTO no later than V_1 , yet as was noted previously, in approximately 58% of the RTO accidents the stop was initiated after V_1 . At heavy weights near V_1 , the airplane is typically traveling at 200 to 300 feet per second, and accelerating at 3 to 6 knots per second. This means that a delay of only a second or two in initiating the RTO will require several hundred feet of additional runway to successfully complete the stop. If the takeoff was at a Field Limit Weight, and there is no excess runway available, the airplane will reach the end of the runway at a significant speed, as shown in Figure 13.

The horizontal axis of Figure 13 is the incremental speed in knots above V_1 at which a **maximum effort** stop is initiated. The vertical

axis shows the **minimum** speed in knots at which the airplane would cross the end of the runway, assuming the pilot used all of the transition time allowed in the AFM to reconfigure the airplane to the stop configuration, and that a maximum stopping effort was maintained. The data in Figure 13 assumes an engine failure not less than one second prior to V_1 and does not include the use of reverse thrust. Therefore, if the pilot performs the transition more quickly than the AFM allotted time, and/or uses reverse thrust, the line labeled "MAXIMUM EFFORT STOP" would be shifted slightly to the right. However, based on the RTO accidents of the past, the shaded area above the line shows what is more likely to occur if a high speed RTO is initiated at or just after V_1 . This is especially true if the RTO was due to something other than an engine failure, or if the stopping capability of the airplane is otherwise degraded by runway surface contamination, tire failures, or poor technique. The data in Figure 13 are typical of a large, heavy jet transport and would be rotated slightly to the right for the same airplane at a lighter weight.

In the final analysis, although the certified accelerate-stop distance calculations provide sufficient runway for a properly performed RTO on a dry runway, the available margins are fairly small. Most importantly, there are no margins to account for initiation of the RTO after V_1 or extenuating circumstances such as runway contamination.

4.3.3.2 The "Go" Option

FAR rules also prescribe minimum performance standards for the "Go" situation. With an engine failed at the most critical point along the takeoff path, the FAR "Go" criteria requires that the airplane be able to continue to accelerate, rotate, liftoff and reach V_2 speed at a point 35 feet above the end of the runway. The airplane must remain controllable throughout this maneuver and must meet certain minimum climb requirements. These handling characteristics and climb requirements are demonstrated many times throughout the certification flight test program. While a great deal of attention is focused on the engine failure case, it is important to keep in mind that, **in nearly three-quarters of the RTO accident cases, full takeoff power was available.**

It is likely that each crew member has had a good deal of practice in engine inoperative takeoffs in prior simulator or airplane training. However, it may have been done at relatively light training weights. As a result, the crew may conclude that large control inputs and rapid response typical of conditions near minimum control speeds (V_{mcg}) are always required in order to maintain directional control. However, at the V_1 speeds associated with a typical Field Length Limit Weight, the control input requirements are noticeably less than they at lighter weights.

Also, at light gross weights, the airplane's rate of climb capability with one engine inoperative could nearly equal the all-engine climb

performance at typical inservice weights, leading the crew to expect higher performance than the airplane will have if the actual airplane weight is at or near the takeoff Climb Limit Weight. Engine-out rate of climb and acceleration capability at a Climb Limit Weight may appear to be substantially less than the crew anticipates or is familiar with.

The minimum second segment climb gradients required in the regulations vary from 2.4% to 3.0% depending on the number of engines installed. These minimum climb gradients translate into a climb rate of only 350-500 feet per minute at actual climb limit weights and their associated V_2 speeds, as shown in Figure 14. The takeoff weight computations performed prior to takeoff are required to account for all obstacles in the takeoff flight path. All that is required to achieve the anticipated flight path is adherence by the flight crew to the planned headings and speeds per their pre-departure briefing

Consider a one-engine-inoperative case where the engine failure occurs earlier than the minimum time before V_1 specified in the rules. Because engine-out acceleration is less than all-engine acceleration, additional distance is needed to accelerate to V_R and, as a consequence, the liftoff point will be moved further down the runway. The altitude (or "screen height") achieved at the end of the runway is somewhat reduced depending on how much more than one second before V_1 the engine failure occurs. On a field length limit runway, the height at the end of the runway may be less than the 35 feet specified in the regulations

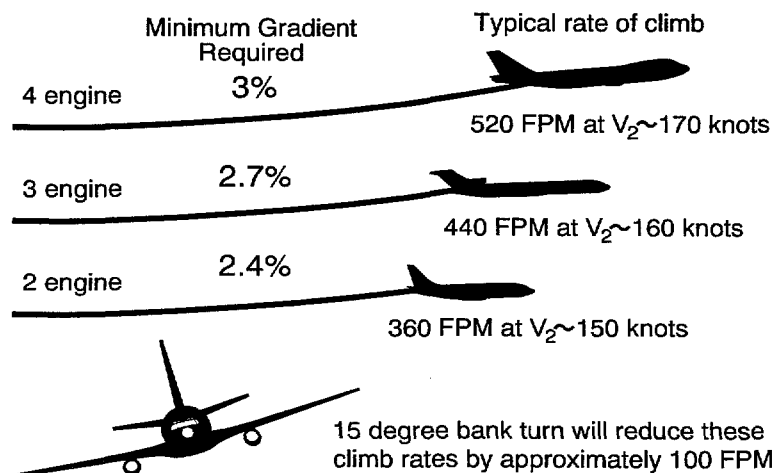

Figure 14
Rate of Climb at
climb limit weight
for 1 engine
inoperative

Figure 15
Effect of engine
failure before V_{EF}
on screen height

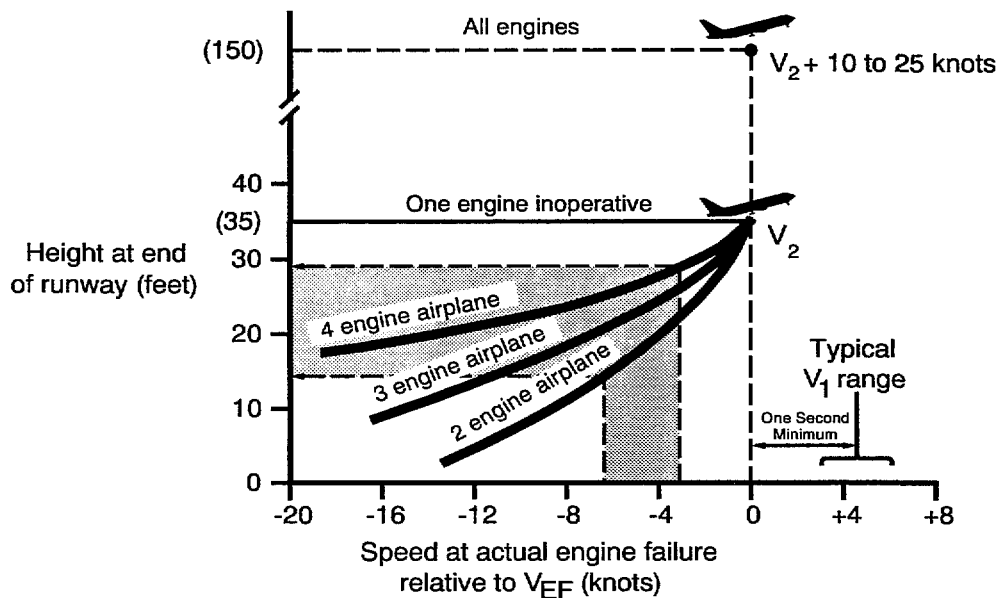

Figure 15 graphically summarizes this discussion of “Go” margins. First, let V_{EF} be the speed at which the Airplane Flight Manual calculation assumes the engine to fail, (a minimum of one second before reaching V_1). The horizontal axis of Figure 15 shows the number of knots prior to V_{EF} that the engine actually fails instead of the time, and the vertical axis gives the “screen height” achieved at the end of the runway. A typical range of acceleration is 3 to 6 knots per second, so the shaded area shows the range in screen height that might occur if the engine actually failed “one second early”, or approximately two seconds prior to V_1 . In other words, a “Go” decision made with the engine failure occurring two seconds prior to V_1 will result in a screen height of 15 to 30 feet for a Field Length Limit takeoff.

Figure 15 also shows that the “Go” performance margins are strongly influenced by the number of engines. This is again the result of the larger proportion of thrust loss when one

engine fails on the two-engine airplane compared to a three or four-engine airplane. On two-engine airplanes, there are still margins but they are not as large, a fact that an operator of several airplane types must be sure to emphasize in training and transition programs.

It should also be kept in mind that the 15 to 30 foot screen heights in the preceding discussion were based on the complete loss of thrust from one engine. If all engines are operating, as was the case in most of the RTO accident cases, the height over the end of the Field Length Limit runway will be approximately 150 feet and speed will be V_2+10 to 25 knots, depending on airplane type. This is due to the higher acceleration and climb gradient provided when all engines are operating and because the required all-engine takeoff distance is multiplied by 115%. If the “failed” engine is developing partial power, the performance is somewhere in between, but definitely above the required engine-out limits.

4.3.4 Operational Takeoff Calculations

As we have seen, the certification flight testing, in accordance with the appropriate government regulations, determines the relationship between the takeoff gross weight and the required runway length which is published in the AFM. By using the data in the AFM, it is then possible to determine, for a given combination of ambient conditions and airplane weight, the required runway length which will comply with the regulations. Operational takeoff calculations, however, have an additional and obviously different limitation. The length of the runway is the Limit Field Length and it is fixed, not variable.

4.3.4.1 The Field Length Limit Weight

Instead of solving for the required runway length, the first step in an operational takeoff calculation is to determine the maximum airplane weight which meets the rules for the fixed runway length available. In other words, what is the limit weight at which the airplane:

- 1) will achieve 35 ft altitude with all engines operating with a margin of 15% of the actual distance used remaining;
- 2) will achieve 35 ft altitude with the critical engine failed prior to V_1 ;
- 3) will stop with an engine failed prior to V_1 and the reject initiated at V_1 ;

...all within the existing runway length available.

The result of this calculation is three allowable weights. These three weights may or may not be the same, but the lowest of the three becomes the Field Length Limit Weight for that takeoff.

An interesting observation can be made at this point as to which of these three criteria will typically determine the Takeoff Field Limit Weight for a given airplane type. Two-engine airplanes lose one-half their total thrust when an engine fails. As a result, the Field Length Limit Weight for two-engine airplanes is usu-

ally determined by one of the engine-out distance criteria. If it is limited by the accelerate-stop distance, there will be some margin in both the all-engine and accelerate-go distances. If the limit is the accelerate-go distance, some margin would be available for the all-engine-go and engine-out-stop cases.

By comparison, four-engine airplanes only lose one-fourth of their takeoff thrust when an engine fails so they are rarely limited by engine-out go performance. The Field Length Limit Weight for a four-engine airplane is typically limited by the 115% all-engine distance criteria or occasionally by the engine-out stop case. As a result, a slight margin frequently exists in both of the engine-out distances on four-engine airplanes.

Three-engine airplanes may be limited by engine out performance or for some models, by a more complex criterion wherein the rotation speed V_R becomes the limiting factor. Since the regulations prohibit V_1 from exceeding V_R , some tri-jets frequently have $V_1=V_R$, and a small margin may therefore exist in the accelerate-stop distance. Two-engine airplanes may occasionally be limited by this $V_1=V_R$ criterion also.

The possible combinations of airport pressure altitude, temperature, wind, runway slope, clearway and stopway are endless. Regardless of airplane type, they can easily combine to make any one of the three previously discussed takeoff field length limits apply. Flight crews have no convenient method to determine which of the three criteria is limiting for a particular takeoff, and from a practical point of view, it really doesn't matter. The slight differences that may exist are rarely significant. Most RTO overrun accidents have occurred on runways where the airplane was not at a limit takeoff weight. That is, the accidents occurred on runways that were longer than required for the actual takeoff weight. Combining this historical evidence with the demanding nature of the high speed rejected takeoff, it would seem prudent that the crew should always assume the takeoff is limited by the accelerate-stop criteria when the takeoff weight is Field Length Limited.

4.3.4.2 Actual Weight Less Than Limit Weight

Returning to the operational takeoff calculation, the second step is to then compare the actual airplane weight to the Field Length Limit Weight. There are only two possible outcomes of this check:

- 1) The actual airplane weight could equal or exceed the Field Length Limit Weight, or
- 2) The actual airplane weight is less than the Field Length Limit Weight.

The first case is relatively straightforward, the airplane weight cannot be greater than the limit weight and must be reduced. The result is a takeoff at a Field Length Limit Weight as we have just discussed. The second case, which is typical of most of jet transport operations, is worthy of further consideration.

By far, the most likely takeoff scenario for the line pilot is the case where the actual airplane weight is less than any limit weight, especially the Field Length Limit Weight. It also is possibly the most easily misunderstood area of takeoff performance since the fact that the airplane is not at a limit weight is about all the flight crew can determine from the data usually available on the flight deck. Currently, few operators provide any information that will let the crew determine how much excess runway is available; what it means in terms of the V_1 speed they are using; or how to best maximize the potential safety margins represented by the excess runway. Later on, in Section 4.3.6.8, we will work an example takeoff weight problem which will show how

one major U.S. operator uses this "excess" runway. In this section, however, the discussion is aimed more at the technical definitions side of what it means when the actual airplane weight is less than the Field Length Limit Weight.

As a preface to this discussion, it should be kept in mind that the use of any V_1 adjustment procedure by a flight crew must be contingent on the implementation of a standard operating procedure by an operator which will take into account all the appropriate variables. Unless this data has been provided to the flight crew by their operations department, there is simply no way the crew can make the judgment of how much before V_1 they could lose an engine and still have adequate "Go" performance. Neither do they have any way to estimate with sufficient accuracy, how far beyond V_1 a successful "No Go" maneuver can be initiated. Therefore, we can only recommend that if no adjustment information is provided to the crew, the value of V_1 given in their standard takeoff analysis should be treated as a "limit speed" for rejecting the takeoff.

Let's look again at the figure used in discussing the definition of a Balanced Field condition, only this time, the actual airplane weight is less than the Field Limit Weight for the runway. As a result, it is not necessary to show the Balanced Field Limit V_1 Speed, since it does not apply to the lower actual weight of our example. Figure 16 shows that for a given runway length, if the actual weight is less than the limit weight, there is actually a range of speeds which could be called " V_1 ." The minimum V_1 speed still satisfies the continued takeoff criteria and the maximum V_1 speed meets the rejected takeoff requirements. Of interest here is that any

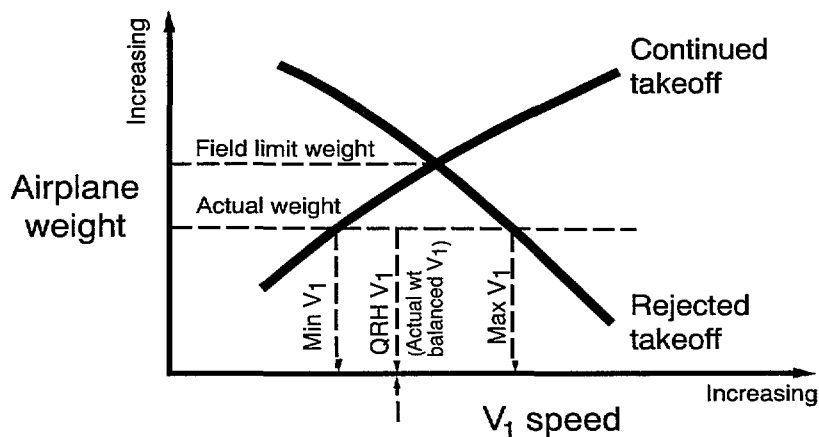

Figure 16
Range of Permissible V_1 speeds when actual weight is less than the limit weight

speed between these two limit speeds would actually provide performance in excess of that specified by the continued or rejected takeoff criteria.

In this situation the operator can choose from several possible courses of action:

Choice 1. Make no adjustment to the V_1 speed provided in the airlines takeoff performance data sheet normally supplied to the crew. Typically this data is based on a "Balanced Field" analysis similar to what was discussed in Section 4.3.1.3, but with a slightly different perspective. As was the case in the previous discussion of a Balanced Field condition, with an engine failed, the point at which the airplane will achieve a 35 foot altitude, or come to a complete stop is the same physical point, but now this point is before the end of the runway. The associated V_1 speed is the one normally listed in the manufacturers Operations Manual, Quick Reference Handbook (QRH), or by onboard computers, where gross weight, altitude and temperature determine the V_1 speeds with no reference to runway length. These speeds are correctly referred to as "Balanced Field speeds" because they were picked such that the corresponding actual "Stop" and "Go" distances are equal. However, it is not correct to think of them as the runway limited V_1 speeds because that is true only if the actual airplane weight is equal to the Field Length Limit Weight.

Choice 2. Adjust the V_1 speed to a lower value. This results in the actual engine-out continued takeoff distance being closer to the limit condition of 35 feet over the end of the runway, and creates an additional margin in the stopping distance required since the stop would begin from a lower speed. Additional details on how this has been implemented by one operator is covered in Section 4.3.6.8.

Choice 3. Adjust the V_1 speed to a higher value. This creates additional altitude over the end of the runway for the "Go" case but puts the actual stopping distance required closer to the end of the runway remaining at V_1 .

Choice 4. Conduct a reduced thrust takeoff, either using a Fixed Derate and/or the Assumed Temperature method, to reduce engine stresses and maintenance costs. Reducing the takeoff thrust causes both the "Stop" and "Go" distances to increase since it takes more distance to accelerate to V_1 . Using the typical takeoff analysis data to accomplish this produces a new "Balanced Field" condition at the lower thrust setting.

Unless the fixed derate chosen exactly matches the thrust required by the actual weight/runway combination, there is still a margin remaining in the "Stop" and "Go" distances, but the original margin is reduced.

Using the Assumed Temperature method of reducing thrust results in margins in both the "Stop" and "Go" distance requirements, even when the maximum assumed temperature is used. This is primarily due to the True Airspeed effects inherent to this method of reducing thrust. Both the fixed derate and assumed temperature methods of reducing thrust are discussed in Section 4.3.5.7.

Choice 5. A combination of reduced thrust with either choice 2 or 3 is possible. Since the primary emphasis here is to maximize the "Stop" margins, the combination of Choice 2, a lower V_1 , with reduced thrust, Choice 4 is recommended.

The next two sections will discuss some of the major factors and physical conditions which affect RTO stopping margins and some general recommendations on how stopping margins are maximized by control of these factors. The example takeoff problem worked in Section 4.3.6.8 provides an easy way to get a feel for the magnitude of the potential margins.

4.3.5 Factors that Affect Takeoff and RTO Performance

The airplane rolls onto the active runway and the power is applied immediately. The airplane quickly accelerates along the smooth dry runway, rotates and climbs briskly into the clear blue sky. You may have done this

many times and seen it happen many more while waiting for your turn for takeoff. It is a truly majestic sight and makes you proud to be in aviation.

In reality, you know that a lot of preparation went into that seemingly simple maneuver. The ground crew checked and serviced the airplane. Dispatch assembled the flight plan, weather briefing, load and trim sheet, and the takeoff performance data. ATC assigned a slot for your departure. The flight crew configured the airplane and are prepared to work as an effective team.

With all the preparation that goes into making a flight, it is not difficult to imagine that most of the thought energy is directed toward completing the flight uneventfully, not encountering a significant difficulty. The passengers, as well as the flight crew are anxious to reach their destination.

It is an abnormal situation when something goes wrong requiring an air turnback or a rejected takeoff. It cancels all of the hard preparation work done by so many and it can result in expensive delays. In the case of a takeoff performed at a limit weight, it can require the crew to use the maximum performance capability of the airplane to successfully complete whichever course of action they choose.

Both the continued and the rejected takeoff performance are directly affected by atmospheric conditions, airplane configuration, runway characteristics, engine thrust available, and by human performance factors. The following sections review the effects of these variables on airplane performance. The purpose is not to make this a complete treatise on airplane performance. Rather, it is to emphasize that changes in these variables can have a significant impact on a successful Go/No Go decision, and in many instances, the flight crew has a degree of direct control over these changes.

4.3.5.1 Runway Surface Condition

The condition of the runway surface can have a significant effect on takeoff performance, since it can affect both the acceleration and deceleration capability of the airplane. The actual surface condition can vary from perfectly dry to a damp, wet, heavy rain, snow, or slush covered runway in a very short time. The entire length of the runway may not have the same stopping potential due to a variety of factors. Obviously, a 10,000 foot runway with the first 7,000 feet bare and dry, but the last 3,000 feet a sheet of ice, does not present a very good situation for a high speed RTO. On the other hand, there are also specially constructed runways with a grooved or Porous Friction Coat (PFC) surface which can offer improved braking under adverse conditions. The crews cannot control the weather like they can the airplane's configuration or thrust. Therefore, to maximize both the "Go" and "Stop" margins, they must rely on judiciously applying their company's wet or contaminated runway policies as well as their own understanding of how the performance of their airplane may be affected by a particular runway surface condition.

Certification testing is performed on a smooth, ungrooved, dry runway. Therefore, any contamination which reduces the available friction between the tire and the runway surface will increase the required stopping distance for an RTO. Runway contaminants such as slush or standing water can also affect the continued takeoff performance due to "displacement and impingement drag" associated with the spray from the tires striking the airplane. Some manufacturers provide advisory data for adjustment of takeoff weight and/or V_1 when the runway is wet or contaminated. Many operators use this data to provide flight crews with a method of determining the limit weights for slippery runways. As was discussed in Section 4.3.1.4, British CAA operators are required to adjust their takeoff performance if the runway is wet. It is also anticipated that a soon to be released FAA proposal will include wet runway takeoff requirements which are similar to the U.K. CAA rules. Factors that make a runway slippery and how it affects the stopping maneuver are included here for reference.

4.3.5.1.1 Hydroplaning

Hydroplaning is an interesting subject since most pilots have either heard of or experienced instances of extremely poor braking action on wet runways during landing. The phenomenon is highly sensitive to speed which makes it an especially important consideration for RTO situations.

As a tire rolls on a wet runway, its forward motion tends to displace water from the tread contact area. While this isn't any problem at low speeds, at high speeds this displacement action can generate water pressures sufficient to lift and separate part of the tire contact area from the runway surface. The resulting tire-to-ground friction can be very low at high speeds but fortunately improves as speed decreases.

Dynamic hydroplaning is the term used to describe the reduction of tire tread contact area due to induced water pressure. At high speeds on runways with significant water, the forward motion of the wheel generates a wedge of high pressure water at the leading edge of the contact area, as shown in Figure 17A. Depending on the speed, depth of water, and certain tire parameters, the portion of the tire tread that can maintain contact with the runway varies significantly. As the tread contact area is reduced, the available braking friction is also reduced. This is the predominant factor leading to reduced friction on runways that have either slush, standing water or significant water depth due to heavy rain activity. In the extreme case, total dynamic hydroplaning can occur where the tire to runway contact area

vanishes, the tire lifts off the runway and rides on the wedge of water like a water-ski. Since the conditions required to initiate and sustain total dynamic hydroplaning are unusual, it is rarely encountered. When it does occur, such as during an extremely heavy rain storm, it virtually eliminates any tire braking or cornering capability at high speeds.

Another form of hydroplaning can occur where there is some tread contact with the runway surface but the wheel is either locked or rotating slowly (compared to the actual airplane speed). The friction produced by the skidding tire causes the tread material to become extremely hot. As indicated in Figure 17B, the resulting heat generates steam in the contact area which tends to provide additional upward pressure on the tire. The hot steam also starts reversing the vulcanizing process used in manufacturing the rubber tread material. The affected surface tread rubber becomes irregular in appearance, somewhat gummy in nature, and usually has a light gray color. This "reverted" rubber hydroplaning results in very low friction levels, approximately equal to icy runway friction when the temperature is near the melting point. An occurrence of reverted rubber hydroplaning is rare and usually results from some kind of antiskid system or brake malfunction which prevented the wheel from rotating at the proper speed.

In the last several years, many runways throughout the world have been grooved, thereby greatly improving the potential wet runway friction capability. As a result, the number of hydroplaning incidents has decreased considerably. Flight tests of one manu-

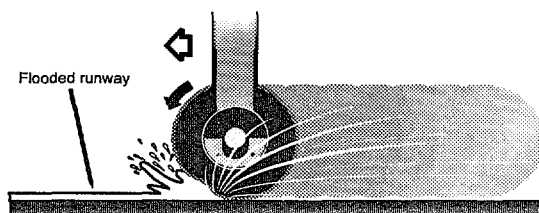

Dynamic Hydroplaning

Figure 17A

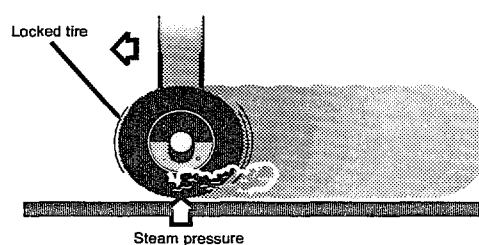

Reverted Rubber Hydroplaning

Figure 17B

facturers airplane on a well maintained grooved runway, which was thoroughly drenched with water, showed that the stopping forces were approximately 90% of the forces that could be developed on a dry runway. Continued efforts to groove additional runways or the use of other equivalent treatments such as porous friction overlays, will significantly enhance the overall safety of takeoff operations.

The important thing to remember about wet or contaminated runway conditions is that for smooth runway surfaces there is a pronounced effect of forward ground speed on friction capability — aggravated by the depth of water. For properly maintained grooved or specially treated surfaces, the friction capability is markedly improved.

4.3.5.1.2 The Final Stop

A review of overrun accidents indicates that, in many cases, the stopping forces available were not used to the maximum during the initial and mid-portions of the stop maneuver, because there appeared to be “plenty of runway available”. In some cases, less than full reverse thrust was used and the brakes were released for a period of time, letting the airplane roll on the portion of the runway that would have produced good braking action. When the airplane moved onto the final portion of the runway, the crew discovered that the presence of moisture on the top of rubber deposits in the touchdown and turnoff areas resulted in very poor braking capability, and the airplane could not be stopped on the runway. When an RTO is initiated on wet or slippery runways, it is especially important to use the full stopping capability until the airplane is completely stopped.

4.3.5.2 Atmospheric Conditions

In general, the lift the wings generate and thrust the engines produce are directly related to the airplane’s speed through the air and the

density of that air. The flight crew should anticipate that the airplane’s takeoff performance will be affected by wind speed and direction as well as the atmospheric conditions which determine air density. Properly accounting for last minute changes in these factors is crucial to a successful Go/No Go decision.

The effect of the wind speed and direction on takeoff distance is very straightforward. At any given airspeed, a 10 knot headwind component lowers the ground speed by 10 knots. Since V_1 , rotation, and liftoff speeds are at lower ground speeds, the required takeoff distance is reduced. The opposite occurs if the wind has a 10 knot tailwind component, producing a 10 knot increase in the ground speed. The required runway length is increased, especially the distance required to stop the airplane from V_1 . There is also an additional conservatism in the wind accountability of the AFM calculations. As required by the regulations, the gain in takeoff performance due to headwind is reduced by 50% and the penalty due to a tailwind is increased by 150%. Typical takeoff data supplied to the flight crew by their operations department will either provide takeoff weight adjustments to be applied to a zero wind limit weight or separate columns of limit weights for specific values of wind component. In either case, it is the responsibility of the flight crew to verify that last minute changes in the tower reported winds are included in their takeoff planning.

The effect of air density on takeoff performance is also straightforward in so far as the crew is normally provided the latest meteorological information prior to takeoff. However, it is the responsibility of the crew to verify the correct pressure altitude and temperature values used in determining the final takeoff limit weight and thrust setting.

4.3.5.3 Airplane Configuration

The planned configuration of the airplane at the time of takeoff must be taken into consideration by the flight crew during their takeoff planning. This should include the usual things like flap selection, and engine bleed configuration, as well as the unusual things like inoperative equipment covered by the Minimum Equipment List (MEL) or missing items as covered by the Configuration Deviation List (CDL). Recommendations on how to accomplish this with an eye toward maximizing the stopping margins will be covered in Section 4.3.6. This section will discuss the effect of the airplane's configuration on takeoff performance capability and/or the procedures the flight crew would use to complete or reject the takeoff.

4.3.5.3.1 Flaps

The airplane's takeoff field length performance is affected by flap setting in a fairly obvious way. For a given runway length and airplane weight, the takeoff speeds are reduced by selecting a greater flap setting. This is because the lift required for flight is produced at a lower V_2 speed with the greater flap deflection. Since the airplane will reach the associated lower V_1 speed earlier in the takeoff roll, there will be more runway remaining for a possible stop maneuver. On the "Go" side of the decision, increasing the takeoff flap deflection will increase the airplane drag, and the resulting lower climb performance may limit the allowable takeoff weight. However, the takeoff analysis used by the flight crew will advise them if climb or obstacle clearance is a limiting factor with a greater flap setting.

4.3.5.3.2 Engine Bleed Air

Whenever bleed air is extracted from an engine and the value of the thrust setting parameter is appropriately reduced, the amount of thrust the engine generates is reduced. Therefore, the use of engine bleed air for air conditioning/pressurization reduces the airplane's potential takeoff performance for a given set of runway length, temperature and altitude conditions.

When required, using engine and/or wing anti-ice further decreases the performance on some airplane models. This "lost" thrust may be recoverable via increased takeoff EPR or N_1 limits as indicated in the airplane operating manual. It depends on engine type, airplane model, and the specific atmospheric conditions.

4.3.5.3.3 Missing or Inoperative Equipment

Inoperative or missing equipment can sometimes affect the airplane's acceleration or deceleration capability. Items which are allowed to be missing per the certified Configuration Deviation List (CDL), such as access panels and aerodynamic seals, can cause airplane drag to increase. The resulting decrements to the takeoff limit weights are, when appropriate, published in the CDL. With these decrements applied, the airplane's takeoff performance will be within the required distances and climb rates.

Inoperative equipment or deactivated systems, as permitted under the Minimum Equipment List (MEL) can also affect the airplane's dispatched "Go" or "Stop" performance. For instance, on some airplane models, an inoperative in-flight wheel braking system may

require the landing gear to be left extended during a large portion of the climbout to allow the wheels to stop rotating. The "Go" performance calculations for dispatch must be made in accordance with certified "Landing Gear Down" Flight Manual data. The resulting new limit takeoff weight may be much less than the original limit in order to meet obstacle clearance requirements, and there would be some excess runway available for a rejected takeoff.

An MEL item that would not affect the "Go" performance margins but would definitely degrade the "Stop" margins is an inoperative anti-skid system. In this instance, not only is the limit weight reduced by the amount determined from the AFM data, but the flight crew may also be required to use a different rejected takeoff procedure in which the throttles are retarded first, the speedbrakes deployed sec-

ond, and then the brakes are applied in a judicious manner to avoid locking the wheels and failing the tires⁴. The associated decrement in the Field Length Limit Weight is usually substantial.

Other MEL items such as a deactivated brake may impact both the continued takeoff and RTO performance through degraded braking capability and loss of in-flight braking of the spinning tire.

The flight crew should bear in mind that the performance of the airplane with these types of CDL or MEL items in the airplane's maintenance log at dispatch will be within the certified limits. However, it would be prudent for the flight crew to accept final responsibility to assure that the items are accounted for in the dispatch process, and to insure that they, as a crew, are prepared to properly execute any revised procedures.

⁴ U.K. CAA procedure adds "...apply maximum reverse thrust."

4.3.5.3.4 Wheels, Tires, and Brakes

The airplane's wheels, tires, and brakes are another area that should be considered in light of the significant part they play in determining the results of a Go/No Go decision.

One design feature which involves all three components is the wheel fuse plug. All jet transport wheels used for braking incorporate thermal fuse plugs. The function of the fuse plug is to prevent tire or wheel bursts by melting if the heat transferred to the wheels by the brake becomes excessive. Melting temperatures of fuse plugs are selected so that with excessive brake-heat, the inflation gas (usually nitrogen) is released before the structural integrity of the tire or wheel is seriously impaired. Both certification limitations and operational recommendations to avoid melting fuse plugs are provided to operators by the manufacturer, as is discussed in Section 4.3.5.3.6 under the heading, Residual Brake Energy.

While fuse plugs provide protection from excessive brake heat, it is also important to recognize that fuse plugs cannot protect against all types of heat induced tire failures. The location of the fuse plug in the wheel is selected to ensure proper response to brake heat. This location in combination with the inherent low thermal conductivity of tire rubber means that the fuse plugs cannot prevent tire failures from the rapid internal heat buildup associ-

ated with taxiing on an underinflated tire. This type of heat buildup can cause a breakdown of the rubber compound, ply separation, and/or rupture of the plies. This damage might not cause immediate tire failure and because it is internal, it may not be obvious by visual inspection. However, the weakened tire is more prone to failure on a subsequent flight. Long taxi distances especially at high speeds and heavy takeoff weights can aggravate this problem and result in a blown tire. While underinflation is a maintenance issue, flight crews can at least minimize the possibility of tire failures due to overheating by using low taxi speeds and minimizing taxi braking whenever possible.

Correct tire inflation and fuse plug protection are significant, but will never prevent all tire failures. Foreign objects in parking areas, taxiways and runways can cause severe cuts in tires. The abrasion associated with sustained locked or skidding wheels, which can be caused by various antiskid or brake problems can grind through the tire cords until the tire is severely weakened or a blow-out occurs. Occasionally, wheel cracks develop which deflate a tire and generate an overloaded condition in the adjacent tire on the same axle. Some of these problems are inevitable. However, it cannot be overstressed that proper maintenance and thorough walk around inspections are key factors in preventing tire failures during the takeoff roll.

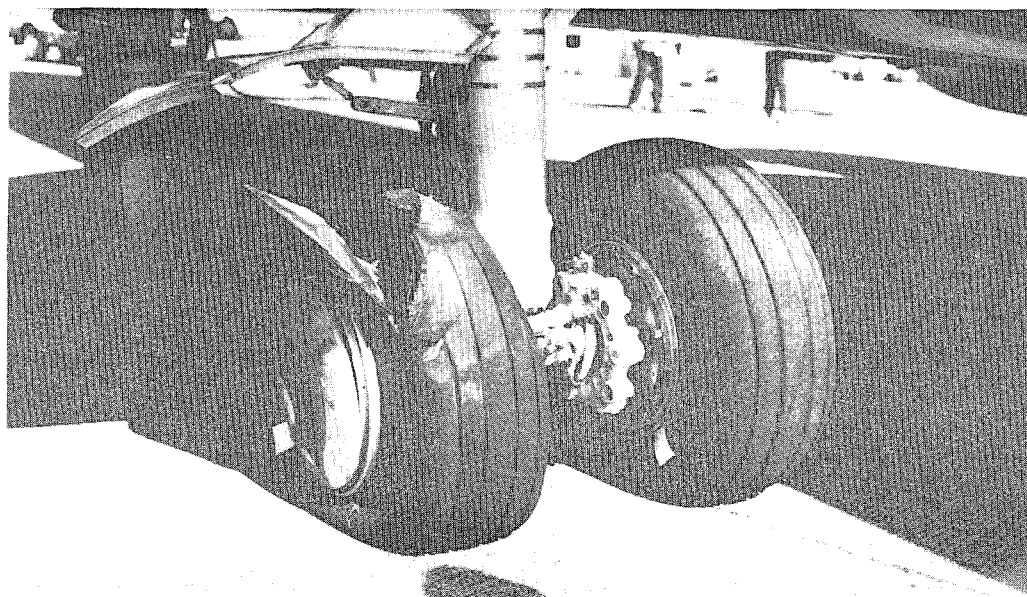

Tire failures may be difficult to identify from the flight deck, and the related Go/No Go decision is therefore, not a simple task. A tire burst may be loud enough to be confused with an engine compressor stall, may just be a loud noise, or may not be heard. A tire failure may not be felt at all, may cause the airplane to pull to one side, or can cause the entire airplane to shake and shudder to the extent that instruments may become difficult to read. Vibration arising out of failure of a nose wheel tire potentially presents another complication. During takeoff rotation, vibration may actually increase at nosewheel lift-off due to the loss of the dampening effect of having the tire in contact with the runway. A pilot must be cautious not to inappropriately conclude, under such circumstances, that another problem exists.

Although continuing a takeoff with a failed tire will generally have no significant adverse results, there may be additional complications as a result of a tire failure. Failed tires do not in themselves, usually create directional control problems. Degradation of control can occur however, as a result of heavy pieces of tire material being thrown at very high velocities and causing damage to the exposed structure of the airplane and/or the loss of hydraulic systems. On airplanes with aft mounted engines, the possibility of pieces of the failed tire being thrown into an engine must also be considered.

An airplane's climb gradient and obstacle clearance performance with all engines operating and the landing gear down exceeds the minimum certified engine-out levels that are used to determine the takeoff performance limits. Therefore, leaving the gear down after a suspected tire failure will not jeopardize the aircraft if all engines are operating. However, if the perceived tire failure is accompanied by an indication of thrust loss, or if an engine problem should develop later in the takeoff sequence, the airplane's climb gradient and/or obstacle clearance capability may be significantly reduced if the landing gear is not retracted. The decision to retract the gear with a suspected tire problem should be in accordance with the airline's/manufacturer's recommendations.

If a tire failure is suspected at fairly low speeds, it should be treated the same as any other rejectable failure and the takeoff should be rejected promptly. When rejecting the takeoff with a blown tire, the crew should anticipate that additional tires may fail during the stop attempt and that directional control may be difficult. They should also be prepared for the possible loss of hydraulic systems which may cause speedbrake or thrust reverser problems. Since the stopping capability of the airplane may be significantly compromised, the crew should not relax from a maximum effort RTO until the airplane is stopped on the pavement.

Rejecting a takeoff from high speeds with a failed tire is a much riskier proposition than continuing, especially if the weight is near the Field Limit Weight. The chances of an overrun are increased simply due to the loss of braking force from one wheel. If additional tires should fail during the stop attempt, the available braking force is even further reduced. In this case, it is generally better to continue the takeoff, as can be seen in Figure 18. The subsequent landing may take advantage of a lower weight and speed if it is possible to dump fuel. Also, the crew will be better prepared for possible vibration and/or control problems. Most important, however, is the fact that the entire runway will be available for the stop maneuver instead of perhaps, as little as 40% of it. As shown in Figure 18, as much as 60% of the runway may remain after stopping the airplane from a landing if fuel dump-

ing is an option. Even in a case where only the minimum fuel is burned off in returning to the field, approximately 40% of the runway would remain available for contingencies.

As can be seen from this discussion, it is not a straightforward issue to define when a takeoff should be continued or rejected after a suspected tire failure. It is fairly obvious however, that an RTO initiated at high speed with a suspected tire failure is not a preferred situation. McDonnell Douglas Corporation, in a recent All Operator Letter⁵, has addressed this dilemma by recommending a policy of not rejecting a takeoff for a suspected tire failure at speeds above $V_1 - 20$ knots. The operators of other aircraft should contact the manufacturer for specific recommendations regarding tire failures.

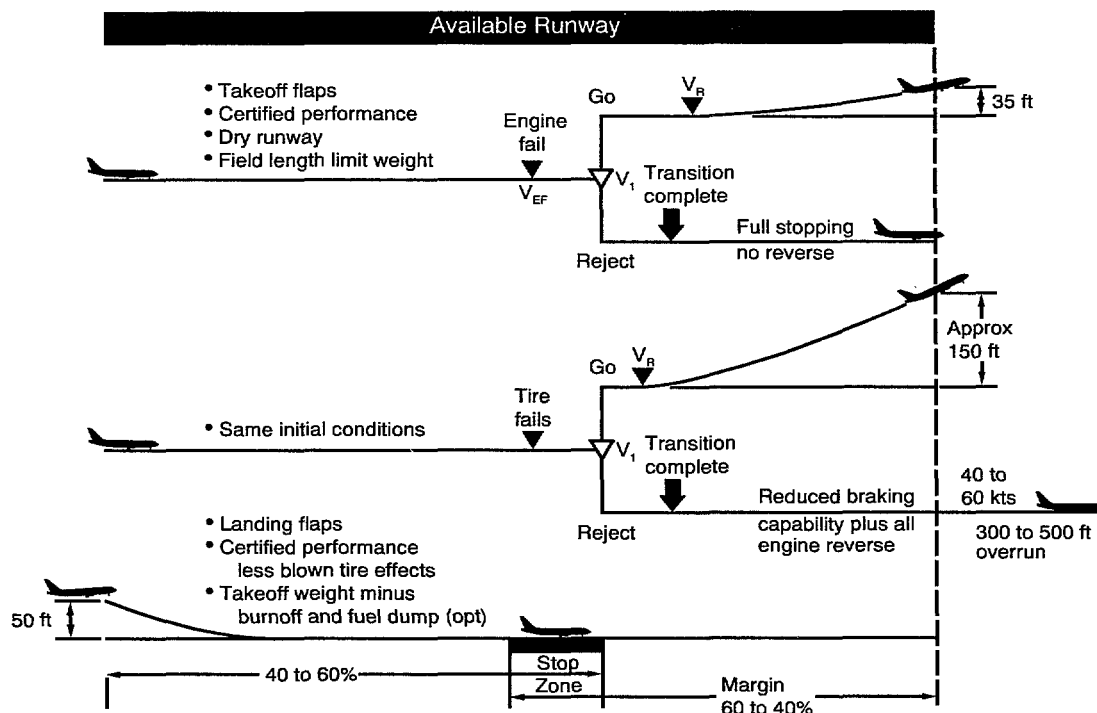

Figure 18
Margin Associated
with continuing or
rejected takeoff
with a tire failure

⁵McDonnell Douglas All Operators Letter FO-AOL-8-003,-9-006,-10-004,-11-015, REITERATION OF PROCEDURES AND TECHNIQUES REGARDING WHEELS TIRES AND BRAKES, Dated 19 AUG 1991

4.3.5.3.5 Worn Brakes

The investigation of one recent RTO incident which was initiated "very near V_1 ", revealed that the overrun was the result of 8 of the 10 wheel brakes failing during the RTO. The failed brakes were later identified to have been at advanced states of wear which, while within accepted limits, did not have the capacity for a high energy RTO.

This was the first and only known accident in the history of commercial jet transport operation that can be traced to failure of the brakes during an attempted RTO. The National Transportation Safety Board (NTSB) investigated the accident and made several recommendations to the FAA. The recommendations included the need to require airplane and brake manufacturers to verify by test and analysis that their brakes, when worn to the recommended limits, meet the certification requirements. Prior to 1991, maximum brake energy limits had been derived from tests performed with new brakes installed.

The FAA recently mandated a program to test and demonstrate the energy capacity of worn brakes. The test program used the brake manufacturer's dynamometer facilities and is now completed for all FAA certified transport airplanes. Worn brake energy certification is an extensive program which has redefined brake wear limits. For most steel brake part numbers, the allowable wear of the brake has been reduced so that the remaining heat sink material could absorb the required energy.

Worn brake stopping force capability is also undergoing review by the regulatory agencies. Recent tests have shown that at high energy levels some worn brakes exhibit some decrease in stopping force capability as compared to new brakes. This loss in force capability translates into an increase in the stopping distance required. However, the loss is generally less than the force that can be made up by considering the effect of the thrust reversers. Furthermore, in many cases, the full capability of the new brakes as demonstrated during certification testing was not utilized in the development of the AFM. As a result, worn brake capability, even though less than new brake capability, often meets or exceeds

the performance that had been reflected in the AFM.

Virtually all brakes in use today have wear indicator pins to show the degree of wear and when the brake must be removed from the airplane. In most cases, as the brake wears the pin moves closer to a reference point, such that when the end of the pin is flush with the reference (with full pressure applied), the brake is "worn out". As of late 1991, tests have been completed which show that brakes at the allowable wear limit can meet AFM brake energy levels. As a result, "wear pin length" is not significant to the flight crew unless the pin indicates that the brake is worn out and should be removed from service. There are no changes to flight crew or dispatch procedures based on brake wear pin length.

4.3.5.3.6 Residual Brake Energy

After a brake application, the energy which the brake has absorbed is released as heat and until this heat is dissipated, the amount of additional energy which the brake can absorb without failure is reduced. Therefore, takeoff planning must consider the effects of residual brake energy (or brake temperature) if the previous landing involved significant braking and/or the airplane turnaround is relatively short. There are two primary sources of information on this subject. The brake temperature limitations and/or cooling charts in the airplane operating manual provide recommended information on temperature limitations and/or cooling times and the procedures necessary to dissipate various amounts of brake energy. In addition, the Maximum Quick Turnaround Weight (MQTW) chart in the certified AFM is a regulatory requirement that must be followed. This chart shows the gross weight at landing where the energy absorbed by the brakes during the landing could be high enough to cause the wheel fuse plugs to melt and establishes a minimum waiting/cooling time for these cases. The MQTW chart assumes that the previous landing was conducted with maximum braking for the entire stop and did not use reverse thrust, so for many landings where only light braking was used there is substantial conservatism built into the wait requirement.

Most brakes have been designed so that the limiting fuse plug energy is quite high and therefore in most cases, the requirement of the AFM to wait a specified time is not reached. The large majority of dispatches are in this category and no special brake cooling considerations are involved. There are however, cases where landing energies can be significant, especially at high temperature, high altitude fields such as Denver, Johannesburg and Mexico City. For this type of dispatch, the most important case is where the wheel fuse plugs are very hot but do not melt. If on the other hand, one or more fuse plugs do melt as a result of brake energy at landing, the associated wheel and tire assemblies must be replaced and the maintenance will usually take much longer than any MQTW wait requirement. The required brake cooling will be accomplished while maintenance is performed.

If the MQTW chart shows that the mandatory waiting period is required, the airplane can legally be dispatched as soon as the cooling time period has elapsed. If heavy braking was used during the preceding landing, the wheels and tires may still be at relatively high temperatures, i.e., just below the fuse plug release point. Even if the mandatory waiting period was not required, nearly the same temperatures can be involved if the landing parameters were close to the limiting values. The brake energy requirements of the subsequent take-off should be carefully considered since wheels and tires cool very slowly, especially in high ambient temperature and low wind conditions. An RTO performed with the initial wheel temperature at near fuse plug melt temperatures, may result in fuse plug releases before the airplane can be brought to a complete stop. In extreme cases, this type of situation can lead to thrown tire tread damage and/or increased stopping distances. While service history shows that the combination of heavy braking on landing, with a minimum length (MQTW) turnaround, and a significant speed RTO is rare, flight crews should be aware of the potential brake cooling problems and consult the manufacturer's guidance material.

The guidance information for critical brake energy conditions is contained in the Brake Cooling Chart and/or the brake temperature

limitations of the Operations Manual. This chart provides the recommended cooling times and/or brake temperature limits for defined landing conditions which are translated into brake energy values. The chart takes into consideration a number of practical factors such as the level of braking used, thrust reverser activity, and the amount of taxi roll distance. Many cooling charts also correlate Brake Temperature Monitoring System readouts to the recommended cooling times, therefore this system can be a convenient means to predict cooling requirements. Strict adherence to the brake cooling and the MQTW charts will avoid any operational problems with excessive brake heat in a subsequent RTO.

4.3.5.3.7 Speedbrake Effect on Wheel Braking Performance

While jet transport pilots generally understand the aerodynamic drag benefit of speedbrakes and the capability of wheel brakes to stop an airplane, the effect of speedbrakes on wheel brake effectiveness during an RTO is not always appreciated. The reason speedbrakes are so critical is their pronounced effect on wing lift. Depending on flap setting, the net wing lift can be reduced, eliminated or reversed to a down load by raising the speedbrakes, thereby increasing the vertical load on the wheels which can greatly increase braking capability.

Speedbrakes are important since for most braking situations, especially any operation on slippery runways, the torque output of the brake, and therefore the amount of wheel brake retarding force that can be developed is highly dependent on the vertical wheel load. As a result, speedbrakes must be deployed early in the stop to maximize the braking capability. During RTO certification flight tests, the stopping performance is obtained with prompt deployment of the speedbrakes. **Failure to raise the speedbrakes during an RTO or raising them late will significantly increase the stopping distance beyond the value shown in the AFM.**

Figures 19 and 20 summarize the effect of speedbrakes during an RTO. For a typical mid-sized two-engine transport, at a takeoff

weight of 225,000 lbs, the total load on the main wheels at brake release would be approximately 193,000 lbs. As the airplane accelerates along the runway, wing lift will decrease the load on the gear, and by the time the airplane approaches V_1 speed, (137 knots for this example), the main gear load will have decreased by nearly 63,000 lbs. The data in Figure 20 graphically depicts how the forces acting on the airplane vary with airspeed from a few knots before the RTO is initiated until the airplane is stopped. When the pilot begins the RTO by applying the brakes and closing the thrust levers, the braking force rises quickly to a value in excess of 70,000 lbs. The nearly vertical line made by the braking force curve in Figure 20 also shows that the airplane began to decelerate almost immediately, with virtually no further increase in speed.

The next action in a typical RTO procedure is to deploy the speedbrakes. By the time this action is completed, and the wheel brakes have become fully effective, the airplane will have slowed several knots. In this example of an RTO initiated at 137 knots, the airspeed would be about 124 knots at this point. The weight on the main gear at 124 knots would be approximately 141,600 lbs with the speedbrakes down, and would increase by 53,200 lbs when the speedbrakes are raised. The high speed braking capability is substantially improved by this 38% increase in wheel load from 141,600 to 194,800 pounds, which can be seen by noting the increase in braking force to 98,000 pounds. In addition, the speedbrakes have an effect on aerodynamic drag, increasing it by 73%, from 8,500 to 14,700

The combined result, as indicated by the table in Figure 19, is that during the critical, high speed portion of the RTO, the total stopping force acting on the airplane is increased by 34% when the speedbrakes are deployed.

Since both the force the brakes can produce and the aerodynamic effect of the speedbrakes vary with speed, the total effect for the RTO stop is more properly indicated by averaging the effect of the speedbrakes over the entire stopping distance. For this example, the overall effect of raising the speedbrakes is an increase of 14% in the average total stopping force acting throughout the RTO.

One common misconception among pilots is that the quick use of thrust reversers will offset any delay or even the complete lack of speedbrake deployment during an RTO. This is simply not true. On a dry runway, delaying the deployment of the speedbrakes by only 5 seconds during the RTO will add over 300 ft. to the stop distance of a typical mid-sized two-engine jet transport, including the effects of engine-out reverse thrust. As a worst case illustration, if reverse thrust was not used and the speedbrakes were not deployed at all, the AFM stopping distance would be increased by more than 700 ft. Although the exact figures of this example will vary with different flap settings and from one airplane model to another, the general effect will be the same, namely that speedbrakes have a very pronounced effect on stopping performance. Appendix 4-H contains additional data on the effect of these and other procedural errors on the stopping distance requirements of specific airplane models.

Figure 19
Effect of speedbrakes on the stopping capability of a typical mid-size two engine transport

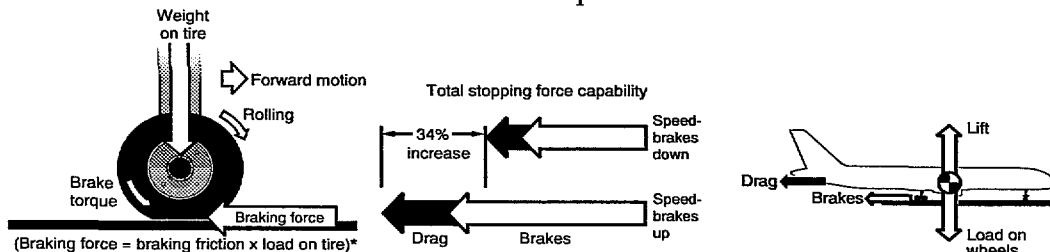

* Brake torque not limiting

	Speedbrake position		Difference speedbrake up
	Down	Up	
Drag	8,500 lbs	14,700 lbs	+73%
Lift	52,000 lbs	-1,200	-102%
Net load on wheels	141,600	194,800	+38%
Max. braking force	75,900	98,000	+29%
Max. stopping force (brakes & drag)	84,400	112,700	+34%

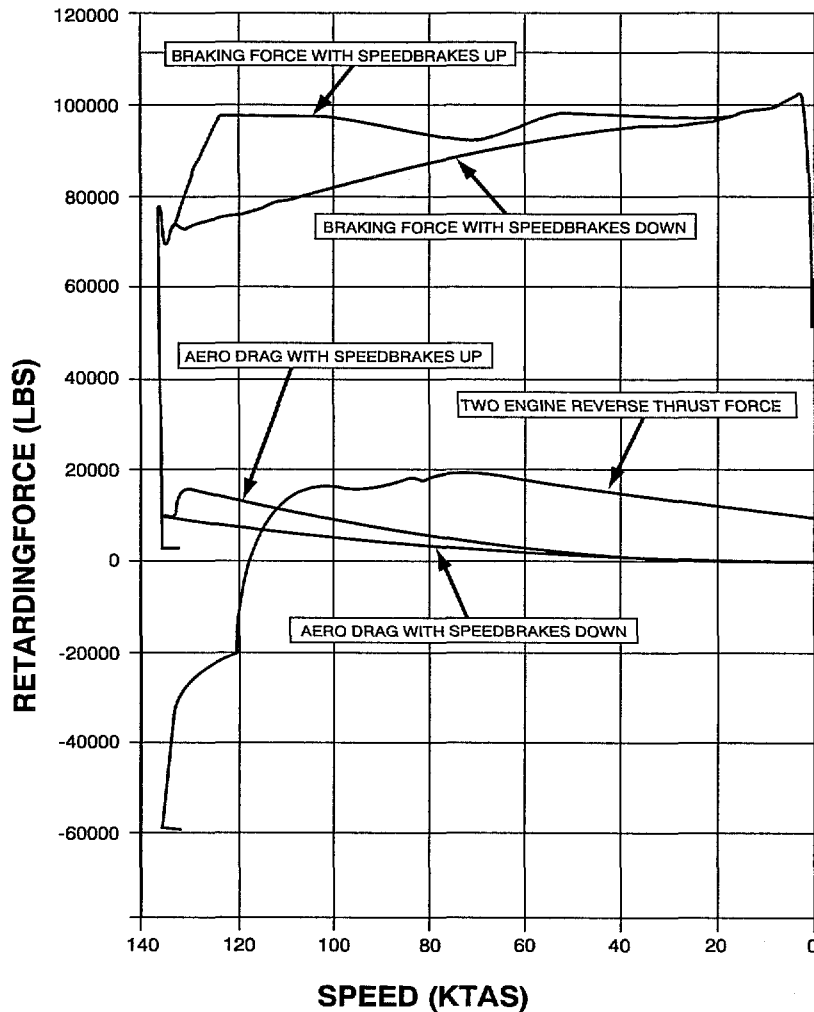

Figure 20
Summary of forces
during a typical
mid-size two engine
airplane RTO

4.3.5.3.8 Carbon and Steel Brake Differences

Recent emphasis on the apparent tendency for carbon brakes to wear out in proportion to the total number of brake applications, as opposed to steel brakes which wear out in proportion to energy absorbed by the brakes, has generated interest in other operational differences between the two types of brakes. While the emphasis on wear difference is necessary, since the economics of brake maintenance is so significant, for most other operational aspects the two brakes can be considered equivalent.

As far as RTO capability is concerned, the type of brake involved does not matter since each brake installation is certified to its particular takeoff energy capability. This means that either carbon or steel brakes, even fully worn, will be able to perform the maximum certified

RTO condition applicable to that installation in a satisfactory manner.

One difference between steel and carbon brakes that is often claimed is an increased tolerance to thermal overload. To understand this in proper perspective, recognize that although the friction elements in a carbon brake (rotating and stationary disks) are made of carbon material which has good strength and friction characteristics at high temperatures, the brake structure, brake hydraulics, the wheel, and the tire are essentially the same as used for an equivalent steel brake. Within the limitations represented by this non-carbon equipment then, an overheated carbon brake will continue to function reasonably well in situations where an equivalent steel brake with its metallic disks might not. An overload condition could be caused by excessive taxi braking,

riding the brakes, or inappropriate turnaround procedures after landing. In this type of situation, carbon brakes will generally demonstrate better friction characteristics and therefore develop more torque and stopping force than equivalent steel brakes.

The difficulty with this carbon brake thermal advantage is that it is nearly impossible to judge the extra amount of braking that could be done before affecting the ability of the non-carbon components to perform in an RTO situation. This is because the thermal effects on the limiting hardware are so highly time and ambient condition dependent. For instance, whether an airplane has carbon brakes or steel brakes will not matter if enough time has elapsed after a heavy brake application such that the wheel fuse plugs release before the airplane can complete the next takeoff or a subsequent RTO attempt. Pilots should concentrate on proper braking procedures rather than attempt to capitalize on any extra carbon brake advantage. Attention to the brake cooling chart recommendations will avoid these thermal problems and ensure that the airplane stopping performance can be achieved regardless of whether steel or carbon brakes are installed.

The increased thermal overload capability of carbon brakes is closely related to the idea that carbon brakes do not "fade". In other words, they always produce the same torque throughout the stop even as the brake temperature increases. Although many carbon brakes do develop nearly constant torque, some fade considerably in certain conditions. On the other hand, some steel brakes do not fade very much at all, depending to a large extent on the degree of conservatism built into the brake. In either case, brake fade is taken into account in the AFM performance, for the specific brake installed on each particular airplane. Therefore, brake fade does not need to be an operational concern to the flight crew.

A second factor with steel brakes is the potential loss of structural strength of the rotors and stators at the extreme operating temperatures associated with limiting energy values. This could cause a structural failure of one or more brake stators near the end of the stop. In this case the brake will continue to function but

with reduced torque capability. The remaining components, which are common to carbon and steel brakes, are less likely to be affected. As a generalization, a steel brake is more exposed to the possibility of structural failure when the temperatures are excessive.

An RTO from at or near the brake energy limits can also mean that after stopping on the runway, the brakes may not be capable of stopping the airplane again, even from low taxi speeds. This is especially true for steel brakes due to the increased chance of structural failure. Therefore, it is important that the crew consider the probable condition of the airplane wheels, brakes, and tires after completing a high speed RTO before attempting to move the airplane from the runway.

One other difference between carbon and steel brakes that might be evident in certain RTO's is brake welding. Steel brakes, which usually have rotors of steel and stators of a copper-iron mix (with a number of special ingredients) can weld together, preventing further wheel rotation. This can even happen before the airplane comes to a full stop, particularly in the last several knots where the antiskid system is not effective. If this does happen, it increases the possibility of a tire blowout as the locked wheel skids to a stop. The energy range where this type of welding can occur is often well below the maximum AFM dispatch energy level but usually above the wheel fuse plug melting level. For most very high energy RTO's, the surfaces of the brake disks remain above the melting point through the entire stop and sometimes for several minutes after. Carbon brakes do not have any tendency to weld together.

Some of the other brake differences are unique to particular designs or to particular design philosophies. For instance, carbon brakes can operate at higher temperatures than steel brakes - provided extra attention is given to protecting the associated equipment. This is typical of most carbon brake designs. However, for some airplane models, commonality and/or interchangeability requirements are more important and have resulted in carbon brakes with the same specified temperature and energy limits as steel brakes.

4.3-5.3.9 High Brake Energy RTO's

Brake rotor and stator temperatures associated with RTO's which involve brake energies at or near certified maximum values, reach approximately 2000°F for most steel brakes. These high temperatures may, in some situations, ignite certain items in the wheel, tire, and brake assembly. While considerable design effort is made to preclude fires whenever possible, the regulations recognize the rarity of such high energy situations and allow brake fires after a minimum energy condition, provided that any fires that may occur are confined to be wheels, tires and brakes, and which would not result in progressive engulfment of the remaining airplane during the time of passenger and crew evacuation. It is important then, for flight crews to understand the nature of possible fires and the airplane takeoff parameters that could involve these very high brake energies.

There are two primary combustibles in the assembly, namely the tire, and brake grease. Brake hydraulic fluid will also burn if there is a hydraulic leak directed at a very hot brake disk. Tire fires can occur if the rubber compound temperature exceeds approximately 650°F. Tire fires usually burn fairly slowly for the first several minutes when started by brake heat. Grease fires are even less active, typically involving a small, unsteady, flickering flame, sometimes with considerable smoke. The probability of a crew experiencing a brake fire at the conclusion of an RTO is very low, considering brake design factors, the dispatch parameters, and service history. The following discussion will assist flight crews in understanding the factors associated with a very high energy stop.

First, not all airlines identify the factor that is limiting for a particular takeoff, such as Field Length, Tire Speed, or Brake Energy. Therefore, the crew may not know if they are at or near a brake energy limit weight. Since the maximum brake energy condition is reflected in the AFM performance by the Maximum Brake Energy Speed, V_{MBE} , and since the

Regulations prevent V_1 from exceeding V_{MBE} , the crew does not necessarily need to know they are brake energy limited to perform a successful RTO. The RTO procedures remain the same.

Second, consider that few of the world's departures are conducted at a Field Length Limit Weight, and only a small proportion of these would be at the Brake Energy Limit Weight where V_1 equals V_{MBE} . More significantly, only a small portion of the RTO's that might occur during these brake energy limited takeoffs would involve a stop from or near V_1 . Service history shows that there have been very few brake fires as a result of high brake energy RTO's. Brake/tire fires occur in service occasionally, but are almost always due to some equipment failure condition during a landing. Fires have also occurred during some airplane brake certification flight test RTO's while attempting to establish maximum brake energy levels. A few have been dramatic and highly publicized but usually result in changes which are incorporated in the wheel/brake design to reduce any unacceptable risk. The final, certified capability is either less than originally tested or the equipment is improved to meet the required capability.

In terms of practical guidelines for flight crews, takeoffs at or near V_{MBE} , are normally encountered at high altitude airports or at very hot temperatures. An RTO from close to V_1 speed under these conditions will require the brakes to absorb a significant amount of energy during the stop. Flight crews can use the Brake Cooling Chart of the airplane operating manual to determine brake energy values if the situation warrants such a review. In cases where an extremely high brake energy might be encountered, the possibility of a brake fire should therefore be considered by the flight crew during the pre-takeoff briefing. If a high speed RTO is subsequently performed the tower should immediately be advised that the airplane is still on the runway, that a high brake energy stop was made, and that emergency equipment is requested to observe the tires and brakes for possible fires.

4.3.5.4 Reverse Thrust Effects

Most of the takeoffs planned in the world do not include reverse thrust credit. This is because the rejected takeoff certification testing under FAA rules does not include the use of reverse thrust. An additional stopping margin is produced by using maximum reverse thrust. We stress the word "maximum" in relation to the use of reverse thrust because of another commonly held misconception. Some pilots are of the opinion that idle reverse is "equally or even more" effective than full or maximum reverse thrust for today's high bypass ratio

engines. This is simply not true. The more EPR or N_1 that is applied in reverse, the more stopping force the reverse thrust generates. The data shown in Figure 21 is typical for all high bypass engines. Similar data on other specific airplane models can be found in Appendix 4-D.⁶

On wet or slippery runways, the wheel brakes are not capable of generating as high a retarding force as they are on a dry surface. Therefore, the retarding force of the reversers generates a larger percentage of the total airplane deceleration.

*Figure 21
Effect of engine
RPM and airspeed
on reverse thrust of
typical high bypass
engine*

Net reverse thrust
for a typical
20,000 lb thrust
engine
(lbs per engine)

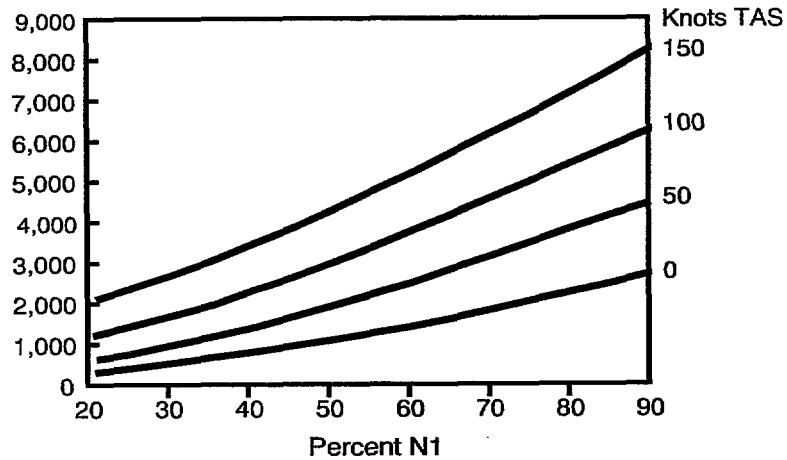

⁶ Boeing Flight Operations Review, Effect Of Engine RPM And Airspeed On Reverse Thrust, 26 June 1990.

4.3.5.5 Runway Parameters

Runway characteristics which affect takeoff performance include length, slope, clearway and/or stopway. The effect of runway length is straightforward; however, slope, clearway, and stopway deserve some discussion.

A single value of runway slope is typically chosen by the operator to perform takeoff analysis calculations. This single value is usually taken from information published by the navigation chart services or the airport authorities. On closer inspection however, many runways are seen to have distinct differences in slope along the length of the runway. The single published value may have been determined by a variety of methods, ranging from a simple mathematical average of the threshold elevations, to some weighted average methods proposed by ICAO in an advisory publication⁷.

As a simple example, consider a runway which has only one slope discontinuity. The first two-thirds of the runway has an uphill slope of +2% and the last third has a downhill slope of -2%. The equivalent single slope for this runway, as determined from the ICAO Circular methods, could vary from +1.3% to -0.3%. When the takeoff analysis is made for this runway, the limit weights will be the same as would be determined for an actual single slope runway. However, as the airplane commences a takeoff on the 2% upslope runway, it will accelerate more slowly than it would on any of the equivalent single slope runways, which will result in its achieving V_1 speed further along the runway than was planned. If no event occurs which would precipitate an RTO, the final acceleration to V_R and liftoff will be higher than planned and the overall performance will probably come out close to what was scheduled.

On the other hand, if an event worthy of an RTO should occur just prior to the airplane reaching V_1 , most, if not all of the stop maneu-

ver will have to be carried out on a 2% downhill slope surface instead of the equivalent single slope value, and the RTO will have been initiated with less runway remaining than was assumed in determining the limit weight for that takeoff. There is little the crew can do in this type of situation, other than in the vein of situational awareness, emphasize in their briefing that an RTO near V_1 for anything other than a catastrophic event is not advisable.

A clearway is an area at least 500 feet wide centered about the extended centerline of the runway with a slope equal to or less than 1.25%. This area is called the clearway plane. No obstructions, except threshold lights, can protrude above this clearway plane. Use of clearway to increase takeoff weight "unbalances the runway" and results in a lower V_1 speed. The acceleration to V_2 and 35 feet is completed over the clearway. The maximum clearway used to calculate performance is restricted by the regulations to one-half the demonstrated distance from liftoff to 35 feet.

A stopway is an area at least as wide as the runway and centered about the extended centerline. It must be capable of supporting the weight of the airplane without causing damage. Use of stopway also "unbalances the runway" resulting in a higher takeoff weight and increased V_1 speed. An RTO initiated at this V_1 will come to a stop on the stopway. For the sake of completeness, it should be pointed out that not all stopways will qualify as clearways, nor will a clearway necessarily qualify as a stopway. The specified criteria for each must be met independently before it can be used for takeoff performance calculations.

The use of clearway and/or stopway does not necessarily offer any additional margin for RTO stopping. In both cases, the takeoff performance is "unbalanced" by adjusting V_1 speed to plan that the stop will be completed by the end of the paved surface.

⁷ ICAO Circular 91-AN/75, The Effect of Variable Runway Slopes on Takeoff Runway Lengths for Transport Aeroplanes, dated 1968.

4.3.5.6 Lineup Distance Accountability

Up to this point in time, most operators have not adjusted the available takeoff runway for the distance needed to align the airplane with the runway for takeoff. There has been no regulatory requirement to do so, except in Australia and Germany. However, revisions to both the FAR's and the JAR's are in work which, if passed into law, will require that a lineup distance be considered in determining limit takeoff weights. Accounting for runway lineup distances will reduce the available runway length and hence the allowable limit takeoff weight from any given runway. Op-

erators can minimize the impact of runway alignment accountability by rebalancing the limit takeoff weight/ V_1 calculation using separate accelerate-go and accelerate-stop distances adjustments as shown in Figure 22.

The takeoff distance (TOD) adjustment is made based on the initial distance from the main gear to the beginning of the runway since the screen height is measured from the main gear, as indicated by distance "A" in Figure 22. The accelerate-stop distance (ASD) adjustment is based on the initial distance from the nose gear to the beginning of the runway, as indicated by distance "B" in Figure 22.

Figure 22
Line up distance
adjustments

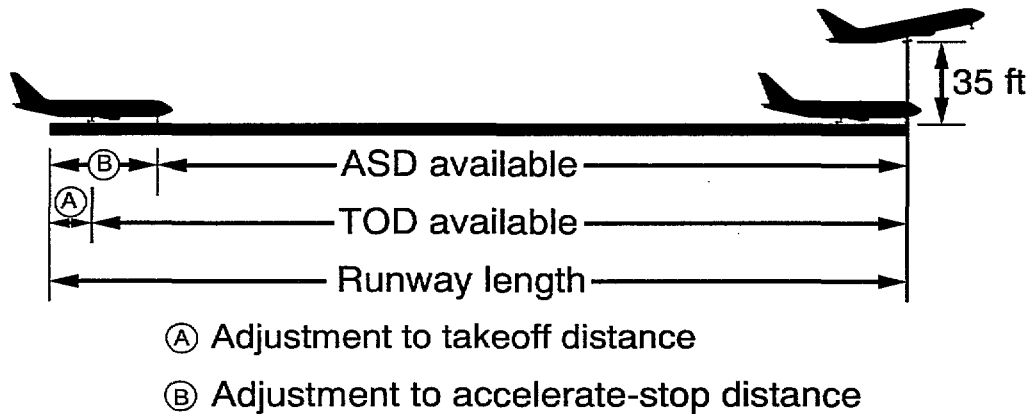

When determining a runway lineup allowance, the characteristics for maneuvering each airplane model onto each runway should be used in calculating the required corrections. For example, runways with displaced takeoff thresholds or ample turning aprons should not need further adjustment. As shown in Figure 23, runways that require a 90 degree turn-on, or taxiing on the runway with a 180 degree turn at the end may require a lineup

adjustment. Appendix 4-I contains the appropriate minimum lineup distance adjustments to both the accelerate-go (TOD) and accelerate-stop (ASD) cases that result from a 90 degree turn onto the runway and a 180 degree turn maneuver on the runway, for all Boeing airplanes. Operators should develop or obtain similar information on other airplanes in their fleet from the manufacturer.

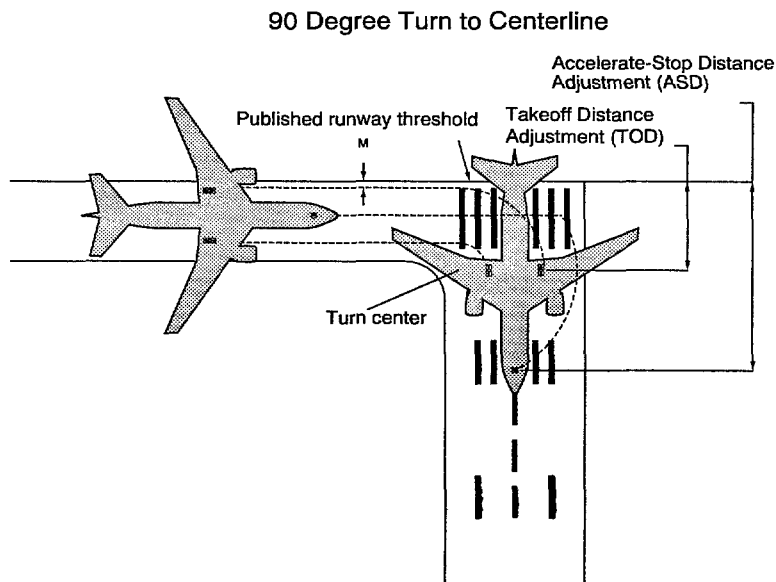
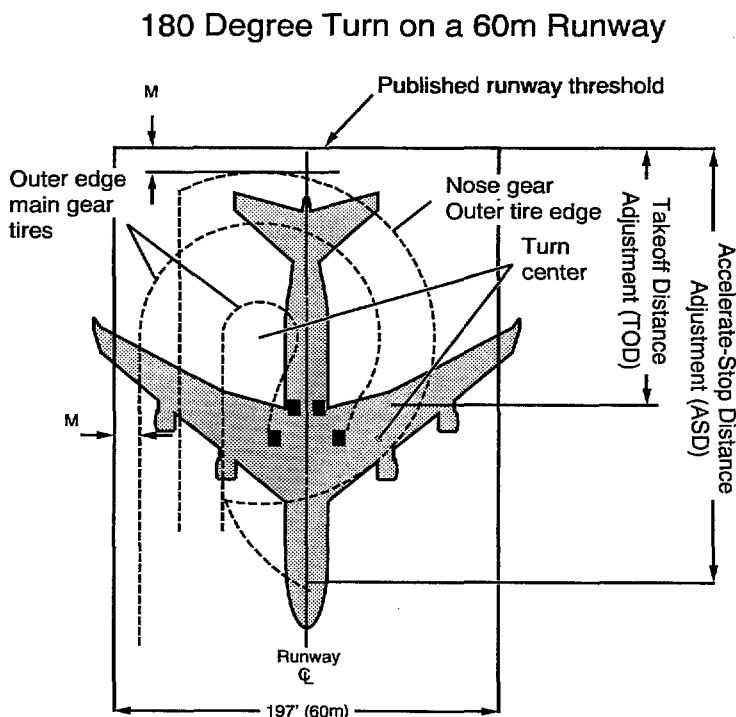

Figure 23
Typical line-up
maneuver



4.3.5.7 Takeoffs Using Reduced Thrust

There are two methods of performing a reduced thrust takeoff. The first is to use a fixed derate of the engine to a lower thrust rating. For example, a JT9D-7F engine operated at a JT9D-7 rating, or a CFM56-3C-1 engine operated at 20,000 lbs of thrust (-B1 rating) instead of the full 23,500 lb rating. When a fixed derate is used, the engine EGT and RPM limits are reduced and the crew are not to exceed the reduced limits in normal operation. As a result of the lower limit thrust with a fixed derate, the minimum control speeds V_{mcg} and V_{mca} are also reduced. Since the choice of derate thrust levels is usually restricted to one or two preselected values, it is rare that the takeoff performance at the derated thrust would be reduced to exactly match field length limit levels. However, if the actual airplane weight should equal the Field Length Limit Weight for the derated thrust, the performance margins are identical to that described in Section 4.3.4.1.

The second way of reducing takeoff thrust is to use the Assumed Temperature Method. The fundamental difference between fixed derates and the Assumed Temperature Method is that the operating limits of the engine are not reduced when using the Assumed Temperature Method. The flight crew may increase the thrust to the full engine rating at any time during the takeoff if it is deemed appropriate. For instance, British CAA Flight Manuals include a recommendation to increase thrust on the operating engines to the full rating in the event that an engine fails during the takeoff. As a result, the V_{mcg} and V_{mca} speeds are not reduced below the full rating values when using the Assumed Temperature Method.

Fixed derates and the Assumed Temperature Method also differ in terms of the performance margins that are inherent to their use. As was previously mentioned, at limit weights, a takeoff performed using a fixed derate takeoff thrust will conform to the minimum performance levels of the regulations, just as a limit weight takeoff would when using full rated takeoff thrust. The associated V_1 speed provides the standard certification "margins" of a 35 foot screen height or a stop at the end of the runway in the event of an engine failure.

When using the Assumed Temperature Method, additional "margins" are created in both the "Go" and "Stop" cases. As the name implies, the technique used to calculate the performance with the Assumed Temperature Method is to assume that the temperature is higher than it actually is, and to calculate takeoff thrust and speeds at the higher temperature.

The primary reason that the use of the Assumed Temperature Method results in performance margins is that the true airspeed of the airplane is lower than would be the case if the actual temperature were equal to the assumed temperature. A typical performance comparison is provided in Figure 24 showing margins in both climb gradient and stopping distance required. A similar comparison for other airplane models is included in APPENDIX 4-H for reference.

It should also be pointed out that the Assumed Temperature Method of reduced thrust can be used in combination with Fixed Derate thrust reduction. The only difference is that the "full Rated Thrust" becomes the Derate value, not the maximum possible engine rating.

An example of the margins inherent in the use of the Assumed Temperature Method is shown in Figure 24 for a typical large four-engine jet transport. The Field Length Limit Weight for the 10,100 ft. runway is 762,200 lbs when the OAT is 16 Deg C, but the actual airplane weight is only 717,500 lbs. This excess weight capability permits the use of an assumed temperature of 40 Deg C.

In this example, if an engine were to fail one second before V_1 , the airplane would reach a height of 35 feet and V_2 speed 750 feet before the end of the runway. If the takeoff were rejected at V_1 , there would be 750 feet more runway available to stop the airplane than would be required. Adding the additional distance margin due to the use of reverse thrust, which for this example airplane is about 270 feet, means that there would be approximately 1020 feet of additional runway available for the RTO.

Conditions: Typical Large Four-Engine Jet Transport
 Sea Level
 OAT = 16 deg C (60 deg F)
 10,100 ft runway
 Field Length Limit Weight=762,200 lbs
 Actual Airplane Weight=717,500 lbs which permits an assumed temperature of 40 deg C.(104 deg F)

Parameter	Actual temp is 16 deg C and assumed temp is 40 deg C	Actual temp is 40 deg C	Resulting Margin
EPR	1.376	1.376	—
V_1 (KIAS/TAS)	146/146	146/152	-6 KTAS
V_R (KIAS/TAS)	156/156	156/163	-7 KTAS
V_2 (KIAS/TAS)	164/164	164/171	-7 KTAS
Thrust at V_1 , lbs per engine	31,210	30,960	250 lbs
FAR Field Length—ft	9,310	10,100	790 ft
Accelerate-stop distance (engine-out)—ft	9,050	9,800	750 ft
Accelerate-go distance (engine-out)—ft	9,050	9,800	750 ft
Accelerate-go distance (all engine)—ft	8,100	8,800	700 ft
Second Segment Gradient	3.54%	3.42%	+0.12%
Second segment rate of Climb—ft per minute	582	586	-4 fpm

Figure 24
 An Example of the conservatism inherent in the use of the assumed temperature method of reduced thrust

4.3.5.8 The Takeoff Data the Pilot Sees

Let's look at the takeoff data from the standpoint of the data used to plan the takeoff. The typical takeoff data table (sometimes referred to as runway analysis or gross weight tables) shows the limit takeoff weight for a specific runway over a range of ambient temperatures. There may also be corrections for wind, pressure altitude, bleed configurations, and runway surface conditions. Each table usually shows the limit weights for only one flap setting. Some airlines show the takeoff speeds and the takeoff thrust EPR or N_1 setting along with the limit weights. The tables can display limit weights for Field Length, Climb, Obstacle Clearance, Tire Speed and Brake Energy, and tell which factor is limiting for each wind and temperature. This tabular display of the takeoff data has become the standard tool for using the assumed temperature method to reduce the takeoff power setting and thereby improve engine life.

This takeoff data is some of the most important data used on any flight. It is essential that flight crews know their actual takeoff weight and that they use the proper takeoff speeds. It is equally important that the flight crew be aware of their proximity to the limit weights for that takeoff's ambient conditions. These limit weights and speeds are more than just numbers. They represent the maximum certified takeoff performance of the airplane. If the actual takeoff weight is equal to or near the runway limit weight, the crew should note that fact and be extra alert that a reject from near or at V_1 will require prompt application of the full stopping capability of the airplane to assure stopping on the runway.

If the actual airplane weight is less than the limit weight, the crew should treat the normally obtained V_1 speed as a "limit speed" unless their operations department has provided them with a specific method of unbalancing the V_1 speed to utilize the excess runway available. The operator should assure that a suitable, non-ambiguous method of presenting the V_1 speed is chosen, whether it is a balanced or unbalanced speed.

4.3.6 Increasing the RTO Safety Margins

There are a number of choices and techniques the crew can make and practice that will increase the RTO margins for takeoff. Some involve airline policy and require the publication of additional data (such as multiple flap setting takeoff weight and speed data) and some are just good personal technique.

4.3.6.1 Runway Surface Condition

The crew cannot control the weather like they can the airplane's configuration or thrust. Therefore, to maximize both the "GO" and "STOP" margins, they must rely on judiciously applying their company's wet or contaminated runway policies as well as their own understanding of how the performance of their airplane may be affected by a particular runway surface condition.

4.3.6.2 Flap Selection

8,700 FT RUNWAY SEA LEVEL 37 °C	FLAP SETTING			
	1	5	15	20
Runway limit weight, lb (kg)	358,300 (162,494)	374,200 (169,705)	389,000 (176,417)	393,600 (178,503)
Climb/Obstacle limit weight, lb(kg)	414,100 (187,800)	407,300 (184,717)	393,600 (178,503)	383,000 (173,696)

Figure 25
Typical Large
Two-Engine Jet
Transport Takeoff
Performance

Often the RTO safety margin can be increased by selection of an alternative takeoff flap setting. Consider for example, the effect of takeoff flap selection on the performance limit weights of a typical large two-engine airplane, as shown in Figure 25.

If a flight requires the absolute maximum takeoff weight, the above weight limits would dictate choosing Flaps 15 since 389,000 pounds is the highest weight allowed. Flaps 20 is Climb/Obstacle limited to a lower weight and Flaps 1 and 5 are Runway limited to lower weights. If the actual takeoff weight desired is equal to the maximum limit weight, there is no flap selection option. The takeoff will need to use Flaps 15.

More typical, however, the airplane's actual takeoff weight is well below the maximum. There are then two viable ways to improve RTO stopping distance margin: either by flap selection or by reduced V_1 techniques. Section 4.3.6.8 contains a discussion on reduced V_1 .

If the flight's actual takeoff weight was 374,200 pounds, investigating the above table indicates Flaps 5, Flaps 15, or Flaps 20 are all acceptable. Flaps 5 is runway limited so it offers no additional RTO margin. However, Flaps 15 and Flaps 20 both offer an opportunity for additional stopping distance margin. These additional stopping margins have been calculated for this example and are shown in Figure 26.

Thus, if there are no other constraints such as obstacles or critical noise abatement procedures that would prevent the selection of a greater flap setting, the crew could give themselves 1000 feet of extra stopping distance in case an RTO was required on this takeoff.

Remember that there are some disadvantages to selecting a higher flap setting. These disadvantages include diminished climb performance and slightly more fuel consumed due to the higher drag configuration and the additional flap retraction cleanup time that will be required.

FLAP SETTING	5	15	20
STOPPING MARGIN	ZERO	850 FT	1000 FT

Figure 26
Effect of Flap
selection on RTO
stopping margins

Thus, if there are no other constraints such as obstacles or critical noise abatement procedures that would prevent the selection of a greater flap setting, the crew could give themselves 1000 feet of extra stopping distance in case an RTO was required on this takeoff.

Remember that there are some disadvantages to selecting a higher flap setting. These disadvantages include diminished climb performance and slightly more fuel consumed due to the higher drag configuration and the additional flap retraction cleanup time that will be required.

4.3.6.3 Runway Lineup

Positioning the aircraft on the runway in preparation for takeoff is an important element in maximizing the amount of pavement available for a possible RTO maneuver. Correct runway lineup technique should always be practiced regardless of whether or not there is excess runway available. As discussed in Section 4.3.5.6, optimum runway lineup procedures can be developed by reference to the turning diagrams presented in Appendix 4-I or by contacting the manufacturer. The flight crew should be familiar with their airline's policy on line-up distance and be proficient in executing the proscribed maneuvers. Operators should also encourage airport authorities to provide turn guidance striping on runways requiring 180 deg turns.

Even if a lineup allowance has been made, it is up to the crew operating the flight to align the airplane on the runway using the shortest possible distance. If they can do it in a shorter distance than taken into account by their company, then there is that much extra margin for the takeoff.

4.3.6.4 Setting Takeoff Thrust

At takeoff thrust settings, gas turbine (jet) engines operate at very high RPM. It typically takes several seconds for the engines to spool up from a low idle or taxi thrust to takeoff

power after the thrust levers are advanced. During this time, the aircraft is not accelerating at full potential because the engines are not yet developing full power.

The demonstrated takeoff distance is achieved when the takeoff thrust is set prior to releasing the brakes, but this technique is often not practical in line operations due to expedited takeoff clearances, engine FOD hazards, and passenger comfort. As a result, most takeoffs are performed as "rolling takeoffs", with the thrust being set as the airplane begins the takeoff roll. However, this technique must be accomplished promptly to avoid compromising the takeoff performance. A delayed application of takeoff thrust will increase the time and distance to reach V_1 speed, consequently, less runway will be left to stop the airplane should an RTO be necessary. The thrust should be set promptly, according to the airframe manufacturer's recommendations. The non-flying pilot or Flight Engineer then typically makes any final adjustments and monitors the engines for any abnormalities.

On airplanes equipped with autothrottles, an additional item to be aware of is that some autothrottle systems incorporate "Thrust Hold" features which will stop advancing the thrust levers after the airplane reaches a predetermined threshold airspeed value. A delay in engaging the autothrottle can result in the thrust stabilizing below the takeoff target setting and the initial acceleration being less than required.

The engine instruments should be monitored closely for any abnormal indications. Past RTO accidents have occurred after an engine problem was identified early in the takeoff roll, but no action was initiated until the airplane had reached or exceeded V_1 .

Company operations manuals or training manuals contain correct procedures for setting takeoff thrust. Observing these procedures assures efficient engine acceleration and, as a consequence, proper aircraft acceleration throughout the entire takeoff roll.

4.3.6.5 Manual Brake Application Techniques

Modulation of brake pressure, or “pumping the brakes” was the way most of us were taught to apply automobile brakes when braking conditions were less than favorable. This prevented sustained skids and therefore afforded both better braking and directional control. Both benefits occur because a skidding tire produces less frictional force than a tire which continues to rotate. Flight deck observation and simulator testing, however, both indicate that this technique has at times been carried over into the cockpit of jet transports. With the antiskid control systems in jet transport airplanes this technique is not only totally unnecessary, it results in degraded stopping capability and therefore excessive stopping distance especially for adverse runway conditions. **Proper braking technique in an RTO is to apply full brake pedal force (“stand on it”) and maintain full brake pedal force until the airplane comes to a complete stop.**

The pilot’s foot position relative to the rudder pedal can also have an effect on the achievement of full brake pressure. It was noted during the Takeoff Safety Training Aid Human Performance Study⁸ that foot position during the takeoff roll tends to be an individual preference. Some pilots prefer to have their feet “up on the pedals” to be ready to apply full brakes if required. Pilots who prefer this technique also noted that their toes are “curled back” to avoid unwanted brake applications when applying rudder. The other technique is to rest the heels on the floor during the takeoff roll, and then raise them to be on the pedal to apply full braking. No problems were noted with either technique

One technique which did not work well was also noted, however. It was not possible to apply maximum brake pedal deflection, and hence full brake pressure, if the heel of the foot is left on the floor, unless the pilot has very big feet. In an RTO stop maneuver, the feet should be up on the rudder pedals and steady, heavy pressure applied until the airplane is completely stopped. Pilots should develop a habit of adjusting their seat and the rudder pedals

prior to leaving the gate. The ability to apply maximum brake pedal force as well as full rudder should be checked by both pilots. On some airplane models, the brake pedal force required to set the parking brake is essentially the same as that required to achieve maximum manual braking. On other airplanes, it may be significantly less. It is up to each crew member to be sure that their understanding of the airplane they are currently operating is correct. The data in Appendix 4-G gives the actual brake pedal forces required to achieve maximum brake pressure, to set the parking brake, and to disarm the RTO autobrake.

The importance of maintaining maximum braking and full reverse thrust during an RTO until the airplane “rocks to a stop” cannot be overstressed. During a reject from V_1 , the goal is safety, not passenger comfort. The amount of distance required to decelerate from a given speed at the high weights associated with takeoff is significantly greater than from the same speed at a typical landing weight. If the pilot tries to judge the amount of runway remaining against the current speed of the airplane, the visual perception that the airplane will stop on the runway (“we’ve got it made”) will prompt a decrease in the stopping effort. It is precisely at this point in the RTO that the difference between a successful Go/No Go decision and an accident can occur. The brakes may be nearing their energy absorption limits and the airplane may be entering a portion of the runway contaminated with rubber deposits, which can be very slick if wet. In several of the RTO accidents and incidents of the past, there was excess runway available to complete the stop, but the premature relaxation of the stopping effort contributed to an overrun.

An additional consideration in completing a successful RTO is that the crew should assess the condition of the airplane after it comes to a stop. If there is evidence of a fire or other significant hazard to the passengers, an evacuation on the runway is definitely preferable to “clearing the active.” Every second counts in an actual emergency evacuation. In at least one RTO accident, many of the fatalities were caused by delaying the evacuation until the aircraft was clear of the runway.

⁸ Takeoff Safety Training Aid Human Performance Study, Appendix 4-E

4.3.6.6 Antiskid Inoperative Brake Application

Antiskid inoperative dispatches represent a special case for brake application techniques. In this situation the pilot executing the RTO should apply steady moderate pedal pressure consistent, in his judgment, with runway conditions, airplane dispatch weight and the available runway length. Full brake pressure should not be applied with the antiskid system inoperative due to the risk of tire failure. To minimize the possibility of skidding a tire, which can lead to a blowout, the speedbrakes should be deployed before brakes are applied. This provides the highest possible wheel loads to keep the wheels rotating with the forward motion of the airplane.

4.3.6.7 RTO Autobrakes

Autobrake system functions and crew actions to initiate these functions vary from one airplane model to another. For example, some systems include automatic spoiler extension, others do not. Therefore, training in use of the system must be tailored to the particular system installed. The following discussion illustrates the general intent of autobrake systems.

Brake application is an immediate pilot action when initiating an RTO, and this application should be of maximum effort. An automatic brake application system called "RTO AUTO-BRAKES" is being installed on more and more airplanes today to insure that this critical step is performed as rapidly as possible when an RTO is initiated. This system is designed to automatically apply maximum brake pressure if during the takeoff roll, all of the thrust levers are retarded to idle, and the aircraft speed is above a specified value (usually 85-90 knots). RTO Autobrakes, therefore, achieve the same airplane stopping performance as a proper, manual application of full foot pedal braking. No time delays are built in to the RTO autobrakes such as are used in some landing autobrake settings.

The use of "RTO AUTOBRAKES" eliminates any delay in brake application and assures that maximum effort braking is applied promptly. Possible application delays arising from distractions due to directional control requirements in crosswinds, or application of less than maximum brake force, are completely eliminated. The results of the Takeoff Safety Training Aid Human Performance Study⁹ also suggest that, on the average, those RTO's performed with RTO autobrakes ARMED resulted in more runway distance remaining after the stop than did the RTO's performed using manual braking only. This result is more significant because few pilots left the autobrakes engaged for more than a few seconds before overriding them and applying full manual braking. The difference in stopping performance is attributed to the first few seconds of high deceleration with the autobrakes at full pressure.

When the RTO autobrakes are ARMED for takeoff, the pilot not flying must monitor the system and advise the pilot flying if a DISARM condition occurs. The pilot flying should also monitor the deceleration of the airplane for acceptability and be prepared to apply manual braking if required or, the pilot performing the reject procedure should apply maximum manual braking during the RTO. In this latter case, arming the RTO autobrake function only serves as a backup if for some reason manual braking is not applied.

The brake pedal forces required to disarm the autobrakes may vary significantly between the landing autobrake settings and the RTO autobrake setting of any given airplane, between one airplane model and another of the same manufacturer, as well as between the various manufacturers airplanes. It is not surprising that this point is not fully understood throughout the pilot community. It is important that pilot's be made aware of how the details of any particular airplane's autobrake system might affect RTO performance. For this reason, Appendix 4-G has been included to give the brake pedal forces required to disarm the autobrakes.

⁹ Takeoff Safety Training Aid Human Performance Study, Appendix 4-E

4.3.6.8 Reduced V_1 Techniques

When the actual airplane weight is less than the Field Length Limit Weight, there is more runway available than is required by the regulations to perform the takeoff. As was discussed in Section 4.3.4.2, V_1 can be chosen from a range of permissible speeds between the minimum V_1 and the maximum V_1 . The minimum V_1 speed still satisfies the continued takeoff criteria, the maximum V_1 speed meets the rejected takeoff requirements, and any value of V_1 chosen between these two limit speeds would actually provide performance in excess of that specified by the continued or rejected takeoff criteria. An example would be if the V_1 speed is determined in the usual manner from simplified presentations in the airplane operating manual, Quick Reference Handbook (QRH), or most onboard computer systems. This speed is typically a balanced V_1 which means the actual accelerate-stop and accelerate-go distances will be equal to each other but less than the actual runway available. This is pictured in Figure 27.

If V_1 were reduced to a speed below the QRH value, an additional surplus of accelerate-stop distance is available. However, the lower the

V_1 speed, the greater the spread between V_1 and V_2 and the greater the distance required to accelerate (with one-engine out) to the takeoff safety speed, V_2 . This added engine-out acceleration requirement increases the accelerate-go distance. In fact, it may be possible to reduce V_1 to the minimum V_1 , so that the accelerate-go distance exactly matches the runway available, as shown in the lower portion of Figure 27. The resulting lower V_1 must be checked to insure that it conforms to the V_{mcg} limit criteria for that aircraft.

If the V_1 speed were chosen to be less than the balanced V_1 but greater than the minimum V_1 , additional distance margins would exist for both the continued and rejected takeoff conditions. Any V_1 speed that meets this criteria is referred to as a "reduced V_1 speed" in the remainder of this discussion, and any method used by an operator to determine reduced V_1 speeds is referred to as a "reduced V_1 policy".

Initiating a reduced V_1 policy will require additional procedural and performance information to be disseminated by the operator.

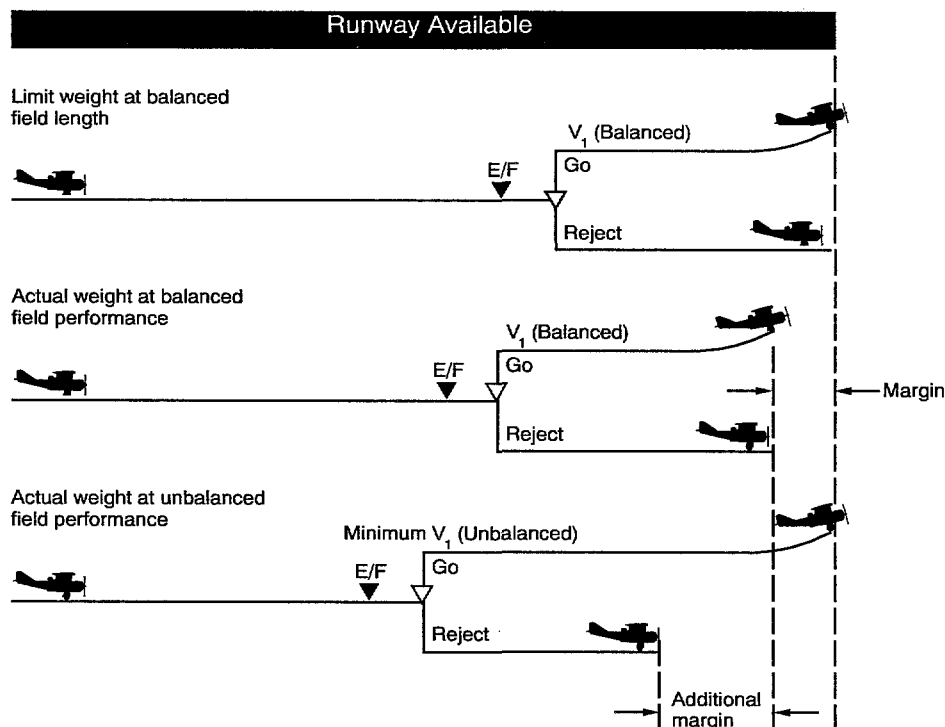

Figure 27
Additional stopping
margin is available by
using reduced V_1
procedures

The basic information required to determine a reduced V_1 speed is currently published in each Airplane Flight Manual. Airline performance engineers can readily establish some simple and conservative delta V_1 /excess weight trades for inservice use. For example one operator has determined that for its area of operation, it is conservative to reduce V_1 by one knot for each 1000 lbs that actual takeoff weight is below the allowable runway weight on one aircraft model in their fleet. A V_1 reduction of one knot per 2000 lbs is used for a different model aircraft. Note, these example trade values are only appropriate for their particular airframe-engine combinations and area of operation. It is cautioned that a reduced V_1 technique such as this should not be used by the flight crew unless an appropriate delta V_1 /weight trade has been established by the operator.

As was seen in Section 4.3.5.7, when the actual weight of the airplane is less than the Field Length Limit Weight, the use of the Assumed Temperature Method to reduce takeoff thrust results in margins in both the Go and Stop distances required.

A reduced V_1 policy can also be effectively used in combination with the Assumed Temperature Method of reduced thrust, thereby maximizing both engine life and RTO stopping margins. An example of this procedure is shown in Figure 28 for a typical large four-engine jet transport.

ELEVATION 0 FT		TYPICAL AIRPORT			
FLAPS 20		JT9D-7 ENGINES/WET			
A/C ON		NORMAL V_1		DRY RUNWAY ZERO WIND	
		RUNWAY 26L		RUNWAY 26R	
QAT	CLIMB	RWY LIMIT	TAKEOFF	RWY LIMIT	TAKEOFF
DEG C	WEIGHT	WEIGHT	SPEEDS	WEIGHT	SPEEDS
	100 LB	100 LB	V_1 -VR-V2	100 LB	V_1 -VR-V2
54	6568	6720F	39-48-55	6963F	39-48-55
52	6664	6786F	40-49-56	7032F	40-49-56
50	6760	6852F	41-50-58	7101F	41-50-58
48	6856	6917F	42-52-59	7168F	42-52-59
46	6952	6982F	44-53-60	7235F	44-53-60
44	7048	7046F	45-54-62	7302F	45-54-62
42	7144	7111F	46-55-63	7369F	46-56-63
40	7240	7175F	46-56-64	7436F	47-57-65
38	7336	7239F	47-57-65	7502F	48-58-66
36	7432	7303F	48-57-65	7568F	50-59-67
34	7534	7369F	49-58-66	7637F	51-61-69
32	7642	7439F	50-59-67	7709F	52-62-70
30	7750	7508F	50-60-68	7781F	54-64-72
28	7750	7117F	50-60-68	7778F	54-64-72
26	7750	7524F	51-60-69	7798F	54-64-72
24	7750	7544F	51-60-69	7818F	54-64-72
22	7750	7564F	51-61-69	7838F	54-64-72
20	7750	7584F	51-61-69	7858F	54-64-72
18	7750	7603F	52-61-70	7877F	54-64-72
16	7750	7622F	52-62-70	7896F	54-64-72
14	7750	7641F	52-62-70	7914F	54-64-72
12	7750	7660F	53-62-71	7933F	54-64-72
10	7750	7680F	53-63-71	7952F	54-64-72

Figure 28
Combining reduced thrust and reduced V_1 to increase stopping margins

MAXIMUM BRAKE RELEASE WT. MUST NOT EXCEED STRUCTURAL LIMIT OF 800,000 LBS
 MINIMUM FLAP RETRACTION HEIGHT IS 400 FT
 LIMIT CODE IS F=FIELD, T= TIRE, B=BRAKE ENERGY, V=VMCG, *=OBSTACLE
 RUNWAY 26L IS 10100 FT LONG WITH 0 FT CLEARWAY 0 FT STOPWAY 0% SLOPE
 RUNWAY 26R IS 11100 FT LONG WITH 0 FT CLEARWAY 0 FT STOPWAY 0% SLOPE
 OBSTACLES CONSIDERED ARE (FROM LIFT/OFF END OF RUNWAY, HT/DIST IN FT/FT):

RUNWAY	HT	DIST
26L	NONE	
26R	NONE	

Recalling the reduced thrust example of section 4.3.5.7, if the actual airplane weight was 717,500 lbs and the actual OAT was 16 Deg C, an assumed temperature takeoff using thrust calculated for 40 Deg C could be made from a 10,100 ft runway. For this example, both the accelerate-stop and accelerate-go actual distances were 750 ft less than would be calculated from the AFM.

But what if a 1000 ft. longer runway was available for this takeoff? In this example, the original runway will be referred to as Runway 26L and the longer runway is Runway 26R. As shown in Figure 28, The Field Length Limit Weight for Runway 26R at 40 Deg C. is 26,100 lbs higher than for Runway 26L. This excess weight capability could be used to further reduce the takeoff thrust setting, however, in this example, the use of a higher assumed temperature is not possible because the Climb Limit (714,400 lbs) is less than the actual weight (717,500 lbs) for temperatures above 40 Deg C.

Since the airplane's climb gradient is not affected by the value of V_1 used, it is now possible to utilize at least a portion of the 1000 ft of excess runway to accelerate to V_2 and climb to 35 ft by reducing the V_1 speed. Using a previously established and conservative delta V_1 / excess weight trade of 1 knot per 2000 lbs, V_1 could be reduced by 13 knots. With this lower value of V_1 , the accelerate-stop distance required is decreased by 2,130 ft. At the same time, the required accelerate-go distance is increased by 380 ft.

Taking into account the possible additional distance margins resulting from the use of the longer runway (1000 ft), engine-out reverse thrust (270 ft), Assumed Temperature Method reduced thrust (750 ft), and reduced V_1 , the total additional runway margins for this example takeoff situation are shown in Figure 29. The data in Appendix 4-H provides additional model specific examples of the use of Assumed Temperature Method reduced thrust and a reduced V_1 policy.

Source	Takeoff Distance (TOD)	Accelerate-Stop Distance (ASD)
Runway 26R	1000 ft.	1000 ft.
Reverse thrust	--	270 ft.
Reduced thrust	750 ft.	750 ft.
Reduced V_1	- 380 ft.	2130 ft.
TOTAL MARGIN	1370 ft.	4150 ft.

*Figure 29
Operational
Margins associated
with reverse
thrust, reduced
thrust, and Reduced
 V_1*

4.3.6.9 The V_1 Call

One important factor in avoiding RTO overrun accidents is for the crew to recognize reaching V_1 when the airplane does, in fact, reach V_1 — not after. The airplane's stopping performance cannot match that specified in the Airplane Flight Manual if the assumptions used to derive that performance are violated -- knowingly or inadvertently. Operationally, careful attention to procedures and teamwork are required to match the human performance recognized by the AFM.

Basic operating procedures call for the pilot flying the airplane to include airspeed in his instrument scan during the takeoff ground roll. Hence he is always aware of the approximate speed. The pilot not flying monitors airspeed in more detail and calls-out "Vee-One" as a confirmation of reaching this critical point in the acceleration.

The pilot flying cannot react properly to V_1 unless the V_1 call is made in a timely, crisp, and audible manner. One method of accomplishing this by a major U.S. carrier is their adoption of a policy of "completing the V_1 callout by the time the airplane reaches V_1 ." This is an excellent example of the way airlines are implementing procedures to improve RTO safety. It is a good procedure and it should preclude a situation where the "No Go" decision is inadvertently made after V_1 . However, the success of such a policy in reducing RTO's after V_1 , without unduly compromising the continued takeoff safety margins, hinges on the line pilot's understanding of the specific airplane model's performance limitations and capabilities.

Another proposal for calling V_1 is to use a call such as "Approaching V_1 " with the V_1 portion occurring as the airspeed reaches V_1 . Either of these proposals accomplish the task of advising the flying pilot that the airplane is close to the speed where an RTO for all but the most serious failures is not recommended.

A frequently cited factor in RTO accidents that occurred when the First Officer was flying, is the lack of any airspeed calls by the Captain during the takeoff. This type of poor crew coordination may be overcome in future airplane designs by the use of automated " V_1 "

and "Engine Failure" calls which will eliminate much of the variability experienced in today's operations. Even with an automated call system however, an "Approaching" call by the non-flying pilot would still seem to be an appropriate method of ensuring airspeed situational awareness for both pilots.

4.3.6.10 Crew Preparedness

Important crew factors directly related to eliminating RTO overrun accidents and incidents are:

- Brief those physical conditions which might affect an RTO that are unique to each specific takeoff.
- Both pilots must be sure to position their seats and rudder pedals so that maximum brake pressure can be applied.
- Both pilots should maintain situational awareness of the proximity to V_1 .
- Use standard callouts during the takeoff.
- Transition quickly to the stopping configuration.
- Don't change your mind. If you have begun an RTO, stop. If you have reached V_1 , go, unless the pilot has reason to conclude that the airplane is unsafe or unable to fly.
- Use maximum effort brake application.
- Assure deployment of speedbrakes.
- Use maximum reverse thrust allowable.

The accident records frequently show that slow or incomplete crew action was the cause of, or contributed to, an RTO overrun event. The crew must be prepared to make the Go/No Go decision on every takeoff. If a "No Go" decision is made, the crew must quickly use all of the stopping capability available. Too often, the records show uncertainty in the decision process and a lack of completeness in the procedures. Be ready to decide and be ready to act.

4.4 Crew Resource Management

Crew Resource Management (CRM) is a term that can mean many things. In this context it is simply intended to encompass the factors associated with having the crew members work effectively together to make optimal Go /No Go decisions and effectively accomplish related procedures. It is recognized that the content of a CRM discussion on Go/No Go decisions must reflect the needs and culture of each individual operator. Therefore, the material contained in this section is provided only as an example of the type of CRM information which could be provided to the line pilot.

4.4.1 CRM and the RTO

Effective CRM can improve crew performance and in particular, decision making during takeoff. Often, Go/No Go decisions must be made "instantaneously" and as a result, the significance of CRM is not readily apparent. However, the fact that a critical decision must be made and implemented using rapidly changing, often incomplete information in a dynamic environment in which the time available decreases as the criticality of the decision increases, is reason for effective CRM. Some aspects of CRM are especially important with respect to the Go/No Go decision.

4.4.2 The Takeoff Briefing

Crew members must know what is expected of them and from others. For optimum crew effectiveness, they should share a common perception - - a mental image - - of what is happening and what is planned. This common perception involves a number of CRM areas: communications, situational awareness, workload distribution, cross-checking and monitoring.

A variety of means are used to achieve this common perception. This begins with airline standard operating policies (SOP's) that clearly define captain and first officer as well as pilot flying and pilot not flying responsibilities and duties. Training reinforces the crew's knowledge and skill, while standardization insures acceptable, consistent performance, across all fleets and cultures within an airline.

A takeoff briefing is another means of improving the crew's awareness, knowledge, and team effectiveness; especially when special circumstances or conditions exist. The briefing is not necessarily a one-way process. In fact, asking for clarification or confirmation is an excellent way to insure mutual understanding when required. A simple, "standard procedures" takeoff briefing might be improved by adding, "I'm not perfect, so back me up on the speedbrakes and my use of the RTO autobrakes" or, "if we're not sure of an engine failure 5 knots before V_1 , we'll continue the takeoff and I'll state 'CONTINUE TAKEOFF'". These briefings can improve team effectiveness and understanding of the Go/No Go decision planning and communications to be used. Such additions might be especially appropriate on the first segment of a flight with a relatively new first officer or a crew's first flight of the month.

A review of actions for a blown tire, high speed configuration warning, or transfer of control are examples of what might be appropriate for before takeoff (or before engine start) review. Such a briefing should address items that could affect this takeoff, such as runway contamination, hazardous terrain or special departure procedures. The briefing should not be a meaningless repetition of known facts, but rather a tool for improving team performance, that addresses the specific factors appropriate to that takeoff.

4.4.3 Callouts

Meaningful communication, however brief, regarding a non-normal situation during takeoff and RTO can often mean the difference between success and disaster. For this reason, communications must be precise, effective, and efficient. Standard callouts contribute to improved situational awareness. These callouts, coupled with all crewmembers being aware of airspeed, maximize the opportunity for a common understanding of what actions are proper in the event of a non-normal situation. The crewmember noting a problem should communicate clearly and precisely without inferring things that may not be true. For example, the loss of fuel flow indication alone does not necessarily mean an engine failure. Use of standard terms and phraseology to describe the situation is essential. The pilot tasked to make the RTO decision should clearly announce this decision, whether it be to continue or reject.

4.4.4 The Use of All Crew Members

It's important to understand that all crewmembers on the flight deck play an important role in the Go/No Go decision and RTO maneuver. Company policies shape these roles, however, how the team is organized for each takeoff can make a difference in team performance. Knowing your own capabilities and that of the other crewmembers is part of situational awareness and should be used in planning for a given takeoff. Although it's "the first officer's leg", it might not be an effective plan to task an inexperienced first officer with a marginal weather takeoff when weight is also limited by field length. Consider the possibility of an RTO when assigning takeoff duties.

4.4.5 Summary

Each airline approaches CRM in a slightly different manner, but the goal of effective teamwork remains the same. This material is an example of the type of CRM information that could be used to promote a common perception of RTO problems and actions.

Takeoff Safety Background Data

List of Appendices

Training Aid Appendix Number	Title and Contents
4-A	<u>Runway Overruns Following High Speed Rejected Takeoffs</u> National Transportation Safety Board (NTSB), Special Investigation Report (SIR -90/02), Dated 27 FEB 90
4-B	RTO Accident/Incident List 1959 to 1990 Listing of the RTO accidents and incidents on which the statistics of the <i>Takeoff Safety Training Aid</i> were developed.
4-C	Other Takeoff Rules Discussion of the regulations of various countries that affect the takeoff performance calculation with respect to RTO's. Also included is a discussion of the U.S. military takeoff rules.
4-D	Reverse Thrust Effectiveness Graphical presentation of the retarding force generated by reverse thrust as a function of speed for typical high bypass jet engines.
4-E	Takeoff Safety Training Aid Human Performance Study Summary report on a Boeing simulator study of airline pilot takeoff decision making and performance.

Takeoff Safety Background Data

List of Appendices (Continued)

Manufacturers' Model Specific Data

Appendix Number	Title and Contents
4-F	<p>Airplane Flight Manual Transition Time Details Graphical presentation of the various certified transition time segments for specific airplane models.</p>
4-G	<p>Brake Pedal Force Data Tabular presentation of the brake pedal pressures required to disarm the Autobrakes, achieve maximum manual brake pressure, and to set the parking brake.</p>
4-H	<p>Reduced Thrust and Reduced V_1 Examples Example calculations showing the inherent margins associated with the Assumed Temperature Method of reduced thrust operation for specific airplane models.</p> <p>Also, as a continuation of the reduced thrust example for each airplane model, a sample calculation of a reduced V_1 speed is performed and the resulting Go and Stop margins are tabulated.</p>
4-I	<p>Lineup Distance Charts Graphical and tabular presentation of the minimum distance required to make a 90 degree turn entry to the runway and 180 degree turns on the runway</p>
4-J	<p>The Effect of Procedural Variations on Stopping Distance Examples of the effect of airplane configuration and variations in RTO procedures on stopping distances, including wet runways.</p>

Takeoff Safety Training Aid

Boeing Data

REVISION HIGHLIGHTS

Revision 1 to the Boeing Model Specific Data
For the Takeoff Safety Training Aid dated April 2, 1993

The following changes comprise the revision:

<u>PAGE</u>	<u>CODE</u>	<u>EXPLANATION</u>
<u>Appendix 4-G</u>		
App.4-G.TBC.3	R1	Added additional Description of 737 RTO autobrake disarm Characteristics.
<u>Appendix 4-J</u>		
App.4-J.TBC.10	R1	Typographical correction to the number of revisions used in the Eng-Out and All-Eng Stop charts.

**National Transportation Safety Board (NTSB)
Special Investigation Report (SIR -90/02)**

**Runway Overruns Following High Speed
Rejected Takeoffs**

4-A

(This page intentionally left blank)

**PB90-917005
NTSB/SIR-90/02**

NATIONAL TRANSPORTATION SAFETY BOARD

SPECIAL INVESTIGATION REPORT

RUNWAY OVERRUNS FOLLOWING HIGH SPEED REJECTED TAKEOFFS

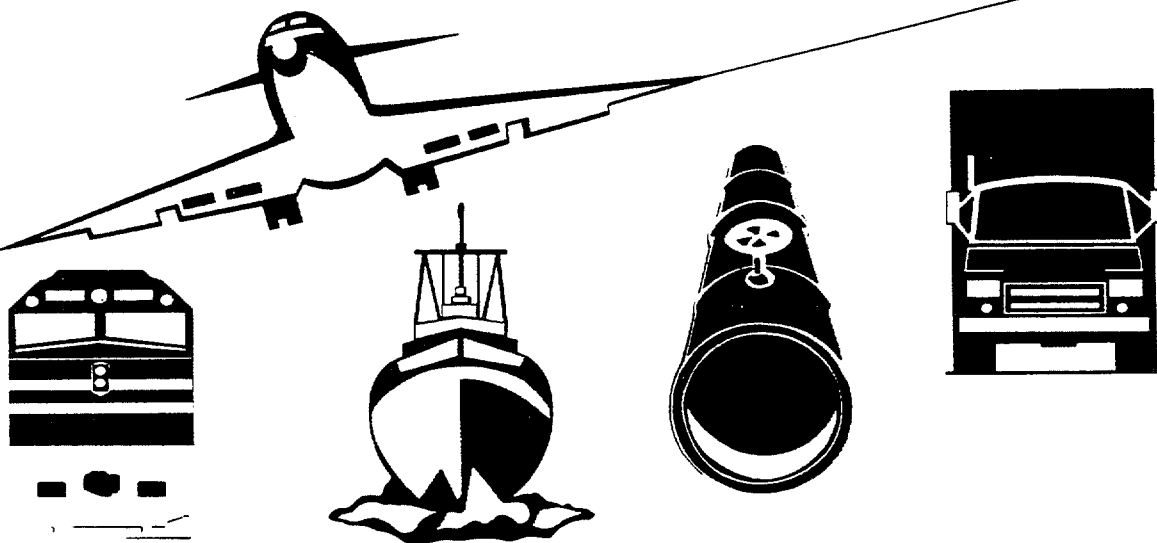

The National Transportation Safety Board is an independent Federal agency dedicated to promoting aviation, railroad, highway, marine, pipeline, and hazardous materials safety. Established in 1967, the agency is mandated by the Independent Safety Board Act of 1974 to investigate transportation accidents, determine the probable cause of accidents, issue safety recommendations, study transportation safety issues, and evaluate the safety effectiveness of government agencies involved in transportation.

The Safety Board makes public its actions and decisions through accident reports, safety studies, special investigation reports, safety recommendations, and statistical reviews. Copies of these documents may be purchased from the National Technical Information Service, 5285 Port Royal Road, Springfield, Virginia 22161. Details on available publications may be obtained by contacting:

**National Transportation Safety Board
Public Inquiries Section, AD-46
800 Independence Avenue, S.W.
Washington, D.C. 20594
(202)382-6735**

TECHNICAL REPORT DOCUMENTATION PAGE

1. Report No. NTSB/SIR-90/02	2. Government Accession No. PB90-917005	3. Recipient's Catalog No.	
4. Title and Subtitle Special Investigation Report-- Runway Overruns Following High Speed Rejected Takeoffs		5. Report Date February 27, 1990	
		6. Performing Organization Code	
7. Author(s)		8. Performing Organization Report No.	
9. Performing Organization Name and Address National Transportation Safety Board Bureau of Accident Investigation Washington, D.C. 20594		10. Work Unit No. 4910D	
		11. Contract or Grant No.	
		13. Type of Report and Period Covered Special Investigation Report	
12. Sponsoring Agency Name and Address NATIONAL TRANSPORTATION SAFETY BOARD Washington, D.C. 20594		14. Sponsoring Agency Code	
15. Supplementary Notes			
16. Abstract This report discusses high speed rejected takeoffs (RTOs) of airplanes. Evidence from investigations conducted from the late 1960s suggests that pilots faced with unusual or unique situations may perform high speed RTOs unnecessarily or may perform them improperly. The Safety Board surveyed a sample of U.S.-based major and national operators to determine how they train their flightcrew members to both recognize the need for and to execute high speed rejected takeoffs. As a result of this special investigation, the Safety Board issued several recommendations to address the guidance and training flightcrew members receive in recognizing the need to execute and in the performance of rejected takeoffs.			
17. Key Words		18. Distribution Statement This document is available to the public through the National Technical Information Service, Springfield, Virginia 22161	
19. Security Classification (of this report) UNCLASSIFIED	20. Security Classification (of this page) UNCLASSIFIED	21. No. of Pages 39	22. Price

CONTENTS

EXECUTIVE SUMMARY	v
INTRODUCTION	1
PREVIOUS RT0 INCIDENTS AND ACCIDENTS	2
EVENTS PRECIPITATING RTOS.	6
RT0-RELATED CERTIFICATION REQUIREMENTS	7
INCREASING THE V_1 STOPPING DISTANCE MARGIN	13
PILOT TRAINING IN RTOS	15
Written Guidance and Procedures.	15
Flight Training.	18
CREW COORDINATION IN PERFORMING RTOS	20
CALLOUTS	21
AUTOBRAKES	22
RECOMMENDATIONS	23
APPENDIXES	27
A Acknowledgments	27
B TWA Flight Data Sheet for JFK's Runway 4L	29
C Federal Express Handout on Rejected Takeoffs.	31

EXECUTIVE SUMMARY

Runway overruns following high speed rejected takeoffs (RTOs) have resulted and continue to result in airplane incidents and accidents. Although most RTOs are initiated at low speeds (below 100 knots) and are executed without incident, the potential for an accident or an incident following a high speed (at or above 100 knots) RTO remains high. In 1988, for example, three RTO-related accidents, two overseas and one in the United States, resulted in injuries to several passengers and crewmembers and in substantial damage to a Boeing 747, a Boeing 757, and in the destruction of a McDonnell Douglas DC-10.

Evidence from investigations conducted from the late 1960s suggests that pilots faced with unusual or unique situations may perform high speed RTOs unnecessarily or may perform them improperly. The Safety Board surveyed a sample of U.S.-based major and national operators to determine how they train their flightcrew members to both recognize the need for and to execute high speed rejected takeoffs. As a result of this special investigation, the Safety Board has issued several recommendations to address the guidance and training flightcrew members receive in recognizing the need to execute and in the performance of rejected takeoffs.

NATIONAL TRANSPORTATION SAFETY BOARD
WASHINGTON, D. C. 20594

SPECIAL INVESTIGATION REPORT

RUNWAY OVERRUNS FOLLOWING HIGH SPEED REJECTED TAKEOFFS

INTRODUCTION

Runway overruns following high speed rejected takeoffs (RTOs) have resulted and continue to result in airplane incidents and accidents. Although most RTOs are initiated at low speeds (below 100 knots) and are executed without incident, the potential for an accident or an incident following an RTO initiated at high speed remains high.¹ In 1988, for example, three RTO-related accidents, two overseas and one in the United States, resulted in injuries to several passengers and crewmembers, in substantial damage to a Boeing 757, a Boeing 747, and in the destruction of a McDonnell Douglas DC-10.

Evidence gathered from previous investigations conducted from the late 1960s suggests that pilots faced with unusual or unique situations may perform high speed RTOs unnecessarily or may perform them improperly. Evidence also indicates that deficiencies exist in (1) pilots' understanding of the risks associated with high speed RTOs, (2) the training pilots receive in RTOs, and (3) the procedures airlines establish for executing RTOs.

The Safety Board conducted this special investigation of RTO-related issues to determine how the safety of RTOs can be enhanced and how the rate of RTO-related accidents and incidents may be reduced. During this investigation, the Safety Board examined a variety of data on RTO accidents and incidents. The Safety Board also observed RTO-related training and examined RTO-related information and procedures of nine airlines in the United States (Appendix A): American Airlines, Continental Airlines, Delta Air Lines, Federal Express, Midway Airlines, Pan American World Airways, Southwest Airlines, Trans World Airlines (TWA), and United Airlines. The airlines, all operating under Title 14 Code of Federal Regulations (CFR) Part 121, some domestically and some domestically and internationally, were chosen to provide an overview of the guidance airlines provide to pilots and to ascertain how well pilots understand the risks associated with a high speed RTO, how well they recognize the need for an RTO, and how well they execute a high speed RTO. The report addresses these issues as well as aspects of Federal Aviation Administration (FAA) certification pertinent to airplane capabilities during a high speed RTO and pilot familiarity with those airplane capabilities.

¹ Throughout this report, a low speed RTO refers to one initiated below 100 knots whereas a high speed RTO refers to one initiated at or over 100 knots.

PREVIOUS RTO INCIDENTS AND ACCIDENTS

According to National Transportation Safety Board data, from 1962 through 1987 there were 45 RTOs involving a variety of domestic and overseas carriers, operating transport category turbojet airplanes in the United States, that caused at least minor damage to the airplane: 22 caused minor damage, 14 caused substantial damage, and 9 destroyed the airplane. Four RTOs resulted in fatalities.

The Boeing Company has analyzed data involving Western-manufactured jet transport airplanes operated worldwide, which have been involved in accidents and incidents, to determine the rate and causes of runway overruns following RTOs. Boeing's analysis (figure 1) indicates that the rate of runway overruns per million departures has decreased considerably from the early 1960s and has remained at a fairly steady rate during the 1980s.

Based on an analysis of its data for transport category aircraft,² Boeing projected 1 RTO in every 3,000 takeoffs and 1 high speed RTO in every 150,000 takeoffs. Boeing also predicted that in 1989, 1 RTO incident or accident would occur in every 2,579,000 takeoffs. Boeing projected a total of 4,500 RTOs, 90 of which would be high speed RTOs resulting in an estimated 5 RTO incidents or accidents. According to Boeing, 3 RTO incidents or accidents occurred in 1989.

The Safety Board is aware that some airlines maintain data bases on RTOs involving the airplanes they operate. The data often include variables such as the type of airplane, nature of the precipitating event, and environmental conditions. The Safety Board believes that airlines should maintain similar data on RTOs that involve the airplanes they operate and has issued Safety Recommendation A-90-14 to the FAA to address this issue.

The following summaries of RTO-related accidents and incidents were selected to illustrate their potential for serious injury.

In August 1972, the crew of a JAT (Yugoslavian Air Transport) Boeing 707 rejected the takeoff from John F. Kennedy International Airport in New York City.³ The RTO was initiated 3 seconds after V_1 ⁴ after the first officer's window opened partially. The crew was unable to stop the airplane on the runway; as a result, 15 persons were injured and the airplane was destroyed. Following its investigation of the accident, the Safety Board concluded that had the crew continued the takeoff, the first officer, because

² Boeing supplied the data to the Safety Board in correspondence dated August 14, 1989.

³ Aircraft Accident Report--"Jugoslovenski Aerotransport (JAT), Boeing 707-331, YU-AGA, John F. Kennedy International Airport, Jamaica, New York, August 13, 1972" (NTSB/AAR-73/7).

⁴ A full discussion of the definition of V_1 follows later in this report.

RTO OVERRUN RATE

1959 thru 1988

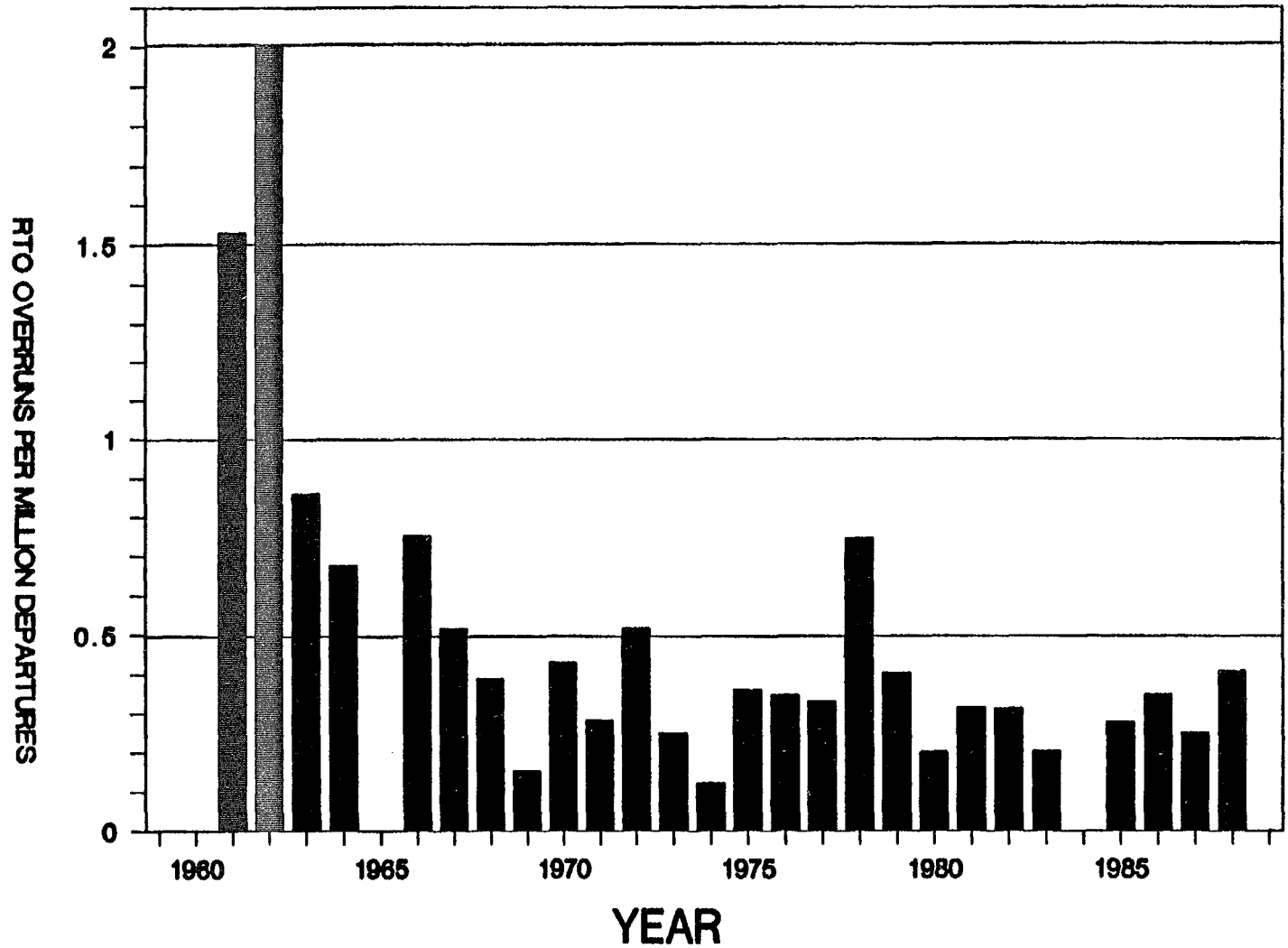

Figure 1. Runway overrun rate.

of the subsequent airplane pressurization, might have been able to close the window in flight.

A month later, a TWA Boeing 707, on a ferry flight from San Francisco, overran the runway and continued into San Francisco Bay following a high speed RTO.⁵ The crew initiated the RTO beyond V_1 after encountering severe vibrations. These vibrations were later determined to have been caused by a failure of the main gear tire. The crew was rescued but the airplane was destroyed.

In November 1976, the crew of a Texas International DC-9-14 encountered a stickshaker activation, indicating an impending aerodynamic stall, 2 seconds after the V_2 call⁶ during takeoff from Denver's Stapleton International Airport.⁷ The crew immediately initiated an RTO; however, the airplane continued its ground roll beyond the end of the runway, traversed drainage ditches, and struck approach light stanchions. The airplane was destroyed and two passengers sustained serious injuries. The investigation determined that the stall warning was false and that a stall was not impending.

In March 1978, the crew of a Continental Airlines McDonnell Douglas DC-10-10 rejected the takeoff from Los Angeles International Airport 3 knots beyond V_1 after hearing loud noises that were later determined to be associated with tire failure.⁸ As the airplane continued its ground roll beyond the end of the runway, the airplane struck ground objects and a fire erupted. The airplane was destroyed, 2 passengers were killed, and 31 passengers and crewmembers were seriously injured in the accident.

In 1982, the crew of a Spanish-registered DC-10-30, operated by Spantax, initiated an RTO following the onset of severe vibrations during rotation upon takeoff from Malaga, Spain.⁹ The aircraft overran the runway, struck objects, and was destroyed. Three crewmembers and 47 passengers were killed.

⁵ Aircraft Accident Report--"Trans World Airlines, Inc., Boeing 707-331C, N15712, San Francisco International Airport, San Francisco, California, September 12, 1972" (NTSB/AAR-73/4).

⁶ V_2 is the takeoff safety speed.

⁷ Aircraft Accident Report--Texas International Airlines, Inc., Douglas DC-9-14, N9104, Stapleton International Airport, Denver, Colorado, November 16, 1976" (NTSB/AAR-77/10).

⁸ Aircraft Accident Report--"Continental Air Lines, Inc., McDonnell-Douglas DC-10-10, N68045, Los Angeles, California, March 1, 1978" (NTSB/AAR-79/1).

⁹ Information on the accident was obtained from advisors to the United States accredited representative to the investigation. The investigation was conducted by the government of Spain.

The vibrations were determined to have been caused by a failure of the nose gear tire.

More recently, the Safety Board has investigated and participated in the investigation of high speed RTO-related incidents and accidents involving several major airlines. On May 21, 1988, N136AA, a McDonnell Douglas DC-10-30, operated as American Airlines flight 70, from Dallas-Fort Worth International Airport to Frankfurt, Federal Republic of Germany, overran the runway following an RTO.¹⁰ The captain rejected the takeoff after hearing a takeoff warning horn and observing a slat disagree light, subsequently determined to have been a false warning, as the airplane reached V_1 . The crew was unable to bring the airplane to a stop on the runway. Two flight crewmembers received serious injuries, one flight crewmember and five passengers received minor injuries, and the airplane was destroyed. The Safety Board concluded that, although the brakes were within FAA-approved wear limits, they were not capable of stopping the airplane on the runway given the airplane's speed and the existing environmental conditions.

On July 23, 1988, a Boeing 747-200 Combi, N4506H, operated as Air France flight 187, from Beijing, People's Republic of China, to Paris, France, ran off the runway following a refueling stop in Delhi, India.¹¹ The investigation determined that a fire warning from the No. 4 engine sounded at or slightly beyond V_1 . The crew's reduction of power occurred as the airplane reached 167 knots; V_1 was 156 knots. The crew was unable to bring the airplane to a stop on the runway, and the airplane struck a ditch beyond the end of the runway. One passenger sustained minor injuries, and the airplane was damaged beyond economic repair.

On September 29, 1988, N523EA, a Boeing 757, operated as an Eastern Airlines flight from San Jose, Costa Rica, to Miami International Airport, Miami, Florida, sustained substantial damage and seven passengers received minor injuries as a result of a high speed RTO. According to information from the government of Costa Rica, which is investigating the accident with the assistance of the National Transportation Safety Board, an unusual sound emanated from the left side of the airplane at or just after V_1 . The captain assumed that the noise resulted from a tire failure and initiated the RTO after rotation had begun during takeoff. The cockpit voice recorder indicates that there was no discussion of or commands regarding initiation of the RTO.

On June 17, 1989, N754DL, a Lockheed L-1011 TriStar operated as Delta Airlines flight 23, en route from Frankfurt, Federal Republic of Germany, to Atlanta, Georgia, sustained minor damage after the airplane partially overran

¹⁰ Special Investigation Report--"Brake Performance of the McDonnell Douglas DC-10-30/40 During High Speed, High Energy Rejected Takeoffs" (NTSB/SIR-90/01)

¹¹ Information on this accident was obtained from advisors to the United States accredited representative to the investigation. The investigation was conducted by the government of India.

the runway following a high speed RTO.¹² According to the government of the Federal Republic of Germany, which is investigating the incident with the assistance of the National Transportation Safety Board, the captain initiated an RTO just beyond V_2 after hearing loud noises from the No. 3 engine. No injuries resulted, but the airplane's brake and wheel assemblies were extensively damaged. The investigation has revealed that a boroscope plug came loose, causing engine damage and an estimated 20 percent loss of thrust. The cockpit voice recorder indicates that the crew was aware that there were no instrument indications of engine failure or engine fire. Contrary to Delta procedures, no callout was made to indicate the nature of the event, and no callout was made to indicate that the captain was initiating an RTO.

On September 20, 1989, a Boeing 737-400, operated as USAir flight 5050, bound for Charlotte, North Carolina, overran the runway following a high speed RTO at New York's LaGuardia Airport. The airplane was destroyed and two passengers were killed. The Safety Board's investigation, which is continuing, has revealed that at least some of the required callouts were not made during the RTO. The captain initiated the RTO at or slightly beyond V_1 .

EVENTS PRECIPITATING RTOS

The evidence indicates that engine failures or engine fires are rarely the precipitating events in high speed RTOS. Ostrowski examined data from a variety of domestic and international sources, including the Safety Board's data base, and found that from 1964 through mid-1976, 171 RTOS resulted in accidents, incidents, or subsequent aircraft repair.¹³ Of the 171 RTOS, 149 were initiated, either wholly or in part, because of failures or malfunctions involving tires, wheels or brakes. Tire failures were a factor in 124 of the 149.

In 1985, a Convair 990, operated by the National Aeronautics and Space Administration (NASA), was destroyed by fire following an RTO. Tire failure, which occurred at a speed below V_1 , precipitated the RTO. None of the 19 passengers or crew were injured. After the accident, NASA examined data on RTO-related incidents and accidents occurring between 1975 and 1987.¹⁴ Of the total 61 RTO-related accidents/incidents found in the data, 34 percent were attributed, at least in part, to tire or wheel failure, 23 percent to engine failure or malfunction, and 43 percent were to a variety of other events.

¹² Information on this investigation was obtained from the United States accredited representative to the investigation.

¹³ Ostrowski, D.W., "Jet transport rejected takeoffs." FAA Report AFS-160-77-2, Federal Aviation Administration, Washington, DC, February 1977.

¹⁴ Batthauer, Byron E., "Analysis of Convair 990 rejected takeoff accident with emphasis on decision making, training and procedures." NASA Technical Memorandum 100189. NASA Lewis Research Center, 1987.

Boeing's analysis of its data on RTO-related incidents and accidents from 1959 through 1988 indicated that non-engine related problems far outnumbered "propulsion anomalies" among the events precipitating RTOs. These included wheel or tire problems and false warnings (figure 2). According to Boeing, the leading cause of the overruns that followed the RTOs was late initiation of the RTO; many of the RTOs were initiated after V_1 (Figure 3). Boeing concluded that over half the RTO cases examined did not warrant RTOs. In each of the selected accidents and incidents briefly described earlier in this report, the RTOs should not have been initiated; that is, the airplanes should have been able to continue the takeoff without incident.

RTO-RELATED CERTIFICATION REQUIREMENTS

Before an aircraft can be introduced into service, it must meet the requirements of 14 CFR 25. One requirement specifies that an airplane manufacturer must demonstrate an airplane's stopping performance, at its maximum operating gross weight, during takeoff. The manufacturer is also required to calculate the takeoff speed, accelerate-stop distance, takeoff distance, and takeoff flight path for the airplane's full range of operating weights. Components of the certification process pertinent to RTOs are briefly discussed below.

V_1 --During the certification process, the manufacturer is required to establish the speed for any operating gross weight at which the takeoff could be safely continued when the most critical engine fails suddenly. Before March 1, 1978, this speed was referred to by the FAA as " V_1 ," the "critical engine failure speed," and was defined as a speed at which, during the takeoff run, the airplane could experience an engine failure and continue to accelerate, lift off, and achieve the required climb gradient.

In actual practice, the process allowed for a delay for the time it took a pilot to recognize that an engine had failed and then to execute the initial RTO action--to retard the throttles on all engines. On March 1, 1978, the FAA amended the pertinent regulations in 14 CFR 1.2 and 14 CFR 25.107 (2) to redefine V_1 as the "takeoff decision speed" and redesignated the "critical engine failure speed" as V_{EF} . Thus, the current airplane certification regulations acknowledge that some amount of time is required by a pilot to recognize and react to an engine failure.

Accelerate-Go Distance--The runway distance that the airplane uses to accelerate after critical engine failure, lift off, and achieve the required height of 35 feet above the surface is referred to as the "accelerate-go distance."

Accelerate-Stop Distance--The stipulations of 14 CFR 25 also require the airplane manufacturer to determine the distance required to accelerate the airplane to V_1 , and then to bring it to a full stop. This distance, referred to as the "accelerate-stop distance," is determined for the full range of operating weights based upon RTO procedures established by the manufacturer. It includes allowance for a certain amount of delay in the pilot's execution of these procedures, delay that may reasonably be expected

CAUSE OF RTO EVENT

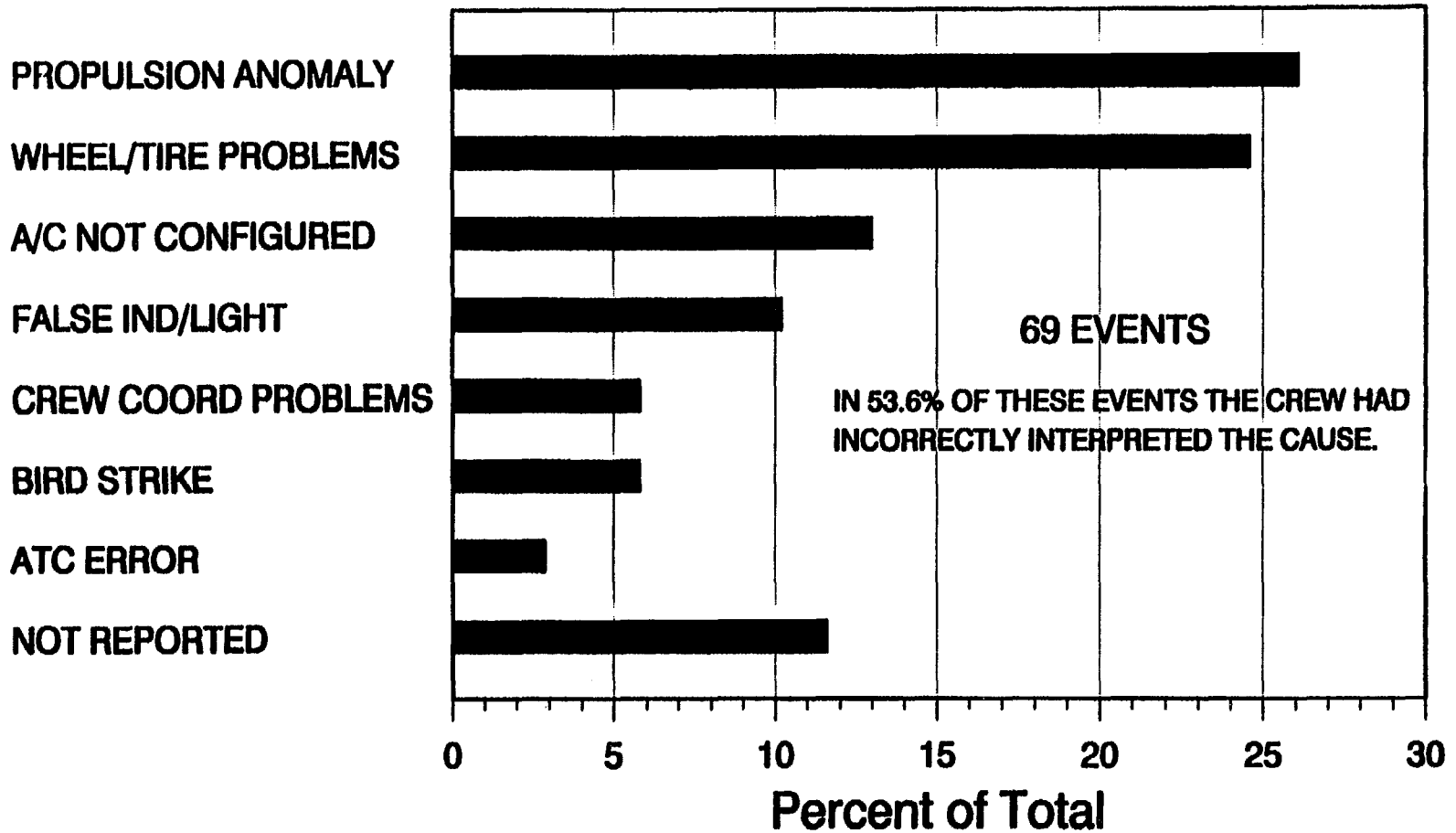

Note:

**RTO accidents and incidents involving
commercial jets - 1959 thru 1988**

Figure 2. Cause of RTOs. (Source: The Boeing Company.)

CAUSE OF OVERRUN

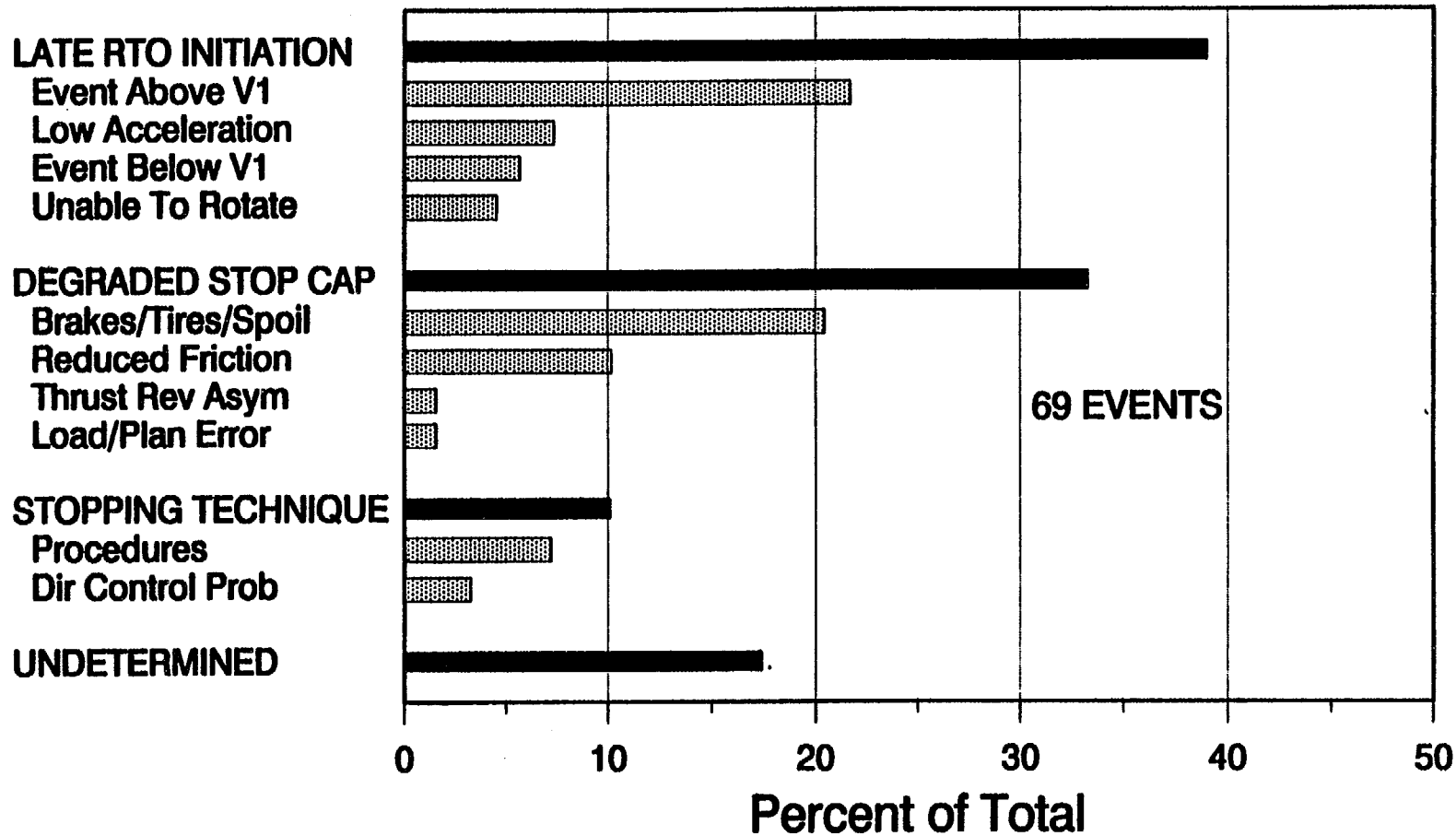

Note:
 RTO accidents and incidents involving
 commercial jets - 1959 thru 1988

Figure 3. Cause of Runway Overruns. (Source: The Boeing Company.)

in service due to reaction time. In establishing data on accelerate-stop distances, the manufacturer must also allow for the use of safe and reliable decelerative devices on the airplane being certificated. The FAA has not permitted the manufacturer to consider the use of reverse thrust to shorten the stopping distance because reverse thrust may not be reliable in the event of an engine failure.

Runway Takeoff Distance.--The data derived during a manufacturer's airplane certification process are included in an FAA-approved flight manual for that airplane. Data on minimum runway length for takeoff are derived for the airplane at various takeoff gross weights with the effects of other factors such as altitude, temperature, wind, and runway gradient included in the calculations. The minimum takeoff runway length must be at least as long as the greatest of the following distances: (1) the "accelerate-go" distance assuming failure of the critical engine at V_{EF} (or, before March 1, 1978, at V_1 with allowance for pilot reaction time); (2) the "accelerate-stop" distance as established during certification; or (3) 115 percent of the distance required for the airplane to take off and climb to a height of 35 feet above the runway surface with all engines operating, commonly referred to as the "all engines go" distance.¹⁵

An incremental decrease in V_1 will increase the accelerate-go distance and decrease the accelerate-stop distance. Therefore, it is to the manufacturer's advantage to optimize the airplane's performance by selecting a V_1 speed for a given set of conditions that will make the accelerate-go and accelerate-stop distances equal. The resultant runway length is said to be "balanced." A balanced runway or balanced field length is the theoretical minimum runway distance needed for an airplane to takeoff unless other criteria--such as minimum control speeds, all engines go performance, obstacle clearance, or brake energy considerations--are limiting.

Airlines use data on minimum runway takeoff distances contained in the FAA-approved flight manual to develop procedures that assure compliance with the appropriate operating rules. Generally, airlines will apply such data to the specific runways at the airports at which they operate to prepare airport analysis charts for quick reference by the flightcrews (an example is given in Appendix B). A chart shows the maximum weight at which the airplane can be operated for a specific runway at various ambient conditions and takeoff flap configurations.

The Safety Board found from its investigations of recent RTO-related accidents that the stopping distance demonstrations for the certification of some airplanes had been conducted with new wheel brakes and from a landing rather than from an actual RTO.¹⁶ The manufacturers then determined the accelerate-stop distance by adding the demonstrated acceleration distance to

¹⁵ The regulations provide allowances for clearways and stopways, which are excluded from this discussion for simplicity.

¹⁶ In 1982, the FAA discontinued accepting demonstrations conducted from a landing as an alternate to demonstration of an actual RTO.

V_1 to the distance needed to bring the airplane to a stop from V_1 . Consequently, the stopping distance determined by this method was predicated on an airplane reaching V_1 speed with unspooled engines, already decelerating, and with cool wheel brakes that had minimum previous wear.

The Safety Board also found that when manufacturers established runway length data for the range of airplane operating weights, they used stopping distances based on the deceleration achieved with maximum brake pressure already applied and did not allow for the distance used during the time required to achieve full brake pressure application from brake pedal depression. Thus, even though the manufacturer applied the required allowances for pilot reaction time to initiate the RTO, the airplane's accelerate-stop performance on which the flight manual data were based could not often be achieved in actual line operations.

The changes introduced to the airplane certification process by the March 1, 1978, amendment to the regulations provide a greater stopping margin for the airplanes that have entered service since that date. However, of the air transport airplanes in service today, only the Airbus Industry A-320 has been required to comply with the amended regulations.¹⁷ Furthermore, even the accelerate-stop distance provided by the amendment to the certification rules might not be achievable in line operations because of the variables affecting takeoff performance that had not been considered in the rules governing certification and operation of the airplane. These variables, discussed below, include runway alignment distance, acceleration rate to V_1 , runway wind component, accuracy of V_1 call and pilot action delays, degraded wheel brake performance, and runway surface friction.

Runway Alignment Distance.--The Safety Board reviewed the methods airlines use to determine the distance they consider in aligning the airplane on the runway before takeoff. United Airlines is the only carrier of the nine observed for the special investigation that considers the length of runway used to align and position the airplane before takeoff is initiated. United calculates this distance to be, on average, about 1.3 times the length of the fuselage and deducts that distance from the runway length available for stopping in the event of an RTO. Other carriers that were observed do not account for this distance because neither the certification data nor the operator's analysis consider the length of the airplane between the main landing gear and nose gear. These factors alone can equal to, and thus negate, the distance margin provided in certification for pilot reaction time delays.

¹⁷ The 1978 amendment would effectively reduce the allowable airplane takeoff gross weight for a given runway, resulting in additional costs that operators and manufacturers believe to be unwarranted. The FAA did not require manufacturers of airplanes for which the FAA had received applications for certification by March 1, 1978, to comply with the amended regulations, regardless of the date the airplane entered service.

Acceleration Rate to V_1 .--Most transport category airplanes are traveling between 220 and 270 feet per second and are accelerating at a rate of about 3 knots per second at V_1 . Variations in the techniques pilots use to set thrust, and variations in the type of thrust selected (full takeoff or derated) and in generation of engine thrust can result in slower takeoff acceleration. As a result, the runway length available to stop an airplane following a high speed RTO is reduced.

Wind Component.--Differences between actual wind direction and velocity and the wind parameters used by the flightcrew to determine the takeoff runway can reduce the stopping distance safety margin in the event of an RTO. For example, an unaccounted-for 5-knot tailwind could reduce the runway stopping distance available in a no-wind condition by 300-500 feet. Further, an airplane will be at a higher ground speed at V_1 with a tailwind, and, thus, will require more distance to stop.

Accuracy of the V_1 Call and Delay in Pilot Reaction.--A 1-second delay by the pilot initiating the RTO after passing the theoretical V_1 speed will substantially decrease the margin between stopping distance required and runway length available because of the airplane dynamics at that speed. Standard procedure among airlines requires the nonflying pilot to make the V_1 call as the airplane passes through that speed. However, often the airplane has surpassed that speed as the pilot makes the V_1 call. This increases the likelihood that an RTO initiated near V_1 may actually be initiated past V_1 . The certification process gives some allowance for pilot action, but not for such factors as airspeed indicator accuracy, or the ability of a nonflying pilot to audibly announce V_1 precisely at the V_1 speed.

Degraded Wheel Brake Performance.--Demonstrations of airplane stopping performance tests are conducted with new brakes. Thus, stopping distances calculated for the FAA-approved flight manual do not account for, and there is no actual evidence to demonstrate the effectiveness of, the worn brakes that are typical of airplanes in service. The Safety Board's special investigation of the brake performance of the DC-10 disclosed that on that airplane a 220-foot to 500-foot increase in stopping distance can be expected if the brakes are worn (See footnote 10).

Runway Surface Friction.--There are no regulations requiring a manufacturer to demonstrate the airplane's stopping performance on wet or slippery runways during the certification process or to provide data relating to such performance. Furthermore, there are no regulations requiring air carriers to consider degraded stopping performance when they determine takeoff weight limitations for specific runways. Although the operating rules require that the minimum length of runway needed for landing be extended by 15 percent when the runway is forecast to be wet, no requirement exists for adjusting the length of runway, or for adjusting aircraft maximum weight, for takeoff. Such adjustments will be discussed in more detail later in this report.

The FAA has not permitted reverse thrust to be used either to demonstrate stopping performance during the airplane certification procedures or to determine the stopping distances for the FAA-approved flight manual.

If reverse thrust was considered, the theoretical stopping distances would be reduced. In actual line flight, a flightcrew performing an RTO would be expected to use reduce thrust. The FAA believes the difference between the theoretical stopping distance, which does not include reverse thrust in its assumptions, and the actual stopping distances, where reverse thrust would be expected to be used, provides a safety margin. This margin, the FAA believes, is sufficient to offset the difference between the actual stopping distance of an airplane and its theoretical stopping distance derived in the absence of the variables described above.

Based on its investigations, analyses of airplane performance, and review of the airplane certification process, the Safety Board believes that reverse thrust does not adequately compensate for the increase in stopping distance that can result from the effect of one or more of the variables not considered in the certification process. An airplane near its maximum takeoff weight may, in the event a high speed RTO is performed, have a minimal or, in some circumstances, nonexistent stopping distance margin.

The Safety Board believes changes are needed in the airplane certification requirements. The Safety Board has issued recommendations to the FAA as a result of the special investigation report of the DC-10-30/40 (see footnote 10).

INCREASING THE V_1 STOPPING DISTANCE MARGIN

Because many important variables are not considered in the airplane certification process, some experts have suggested modifying V_1 to increase the RTO stopping distance margin and thereby enhance the safety of this go/no-go action point. For example, Batthauer (see footnote 14) advocates the use of different speeds according to how critical the precipitating event is. He suggested that "...one consideration could be that when takeoff speeds are between 20 knots below V_1 and V_1 , only an engine failure could cause the initiation of an RTO. Tire failures and less serious anomalies would not automatically prompt an RTO."

Lufthansa has proposed using a takeoff decision speed some knots lower than V_1 so that a pilot can react to an event and perform an RTO before V_1 is actually reached.¹⁸ In the United States, United Airlines requires the nonflying pilot to begin the V_1 call 5 knots before V_1 is actually reached so that V_1 will be heard as that speed is reached. The airline believes this procedure recognizes the necessity for action in initiating an RTO no later than V_1 and assists crewmembers in the proper initiation of an RTO when necessary.

TWA modified its computation of V_1 following a series of RTO-related accidents and incidents in the late 1960s. TWA reduces V_1 by 1 knot for every 1,000 pounds of airplane gross weight under the maximum gross weight for that runway, up to a maximum reduction of 10 knots. The reduction for

¹⁸ Limley, E.A., "Lufthansa Go/No Go Philosophy." Boeing 737 Flight Operations Symposium. September 1985. 3.1.1 - 3.1.10.

the L-1011 TriStar is 1 knot for every 2,000 pounds, up to 10 knots. This reduction moves the V_1 go/no-go action point to an earlier point on the runway and at a lower airplane speed, thereby providing more runway distance should a high speed RTO be executed. Moreover, TWA provides information on the reduced V_1 to crewmembers on takeoff performance data sheets; for certain aircraft, crewmembers are required to complete the data sheet (see Appendix B). This process provides crewmembers with important information on the determination of V_1 .

Another method to improve the safety margin of high speed RTOs is to reduce V_1 under certain conditions; for example, when additional runway length is available beyond the balanced field length, or when runway conditions could hamper the execution of a successful RTO. In 1982, following its special investigation of large airplane operations on contaminated runways, the Safety Board issued two recommendations to the FAA aimed at reducing V_1 , when possible, to the lowest possible safe speed that conditions warrant.¹⁹ The recommendations asked the FAA to:

A-82-163

Amend 14 CFR 25.107, 25.111, and 25.113 to require that manufacturers of transport category airplanes provide sufficient data for operators to determine the lowest decision speed (V_1) for airplane takeoff weight, ambient conditions, and departure runway length which will comply with existing takeoff criteria in the event of an engine power loss at or after reaching V_1 .

A-82-164

Amend 14 CFR 121.189 and 14 CFR 135.379 to require that operators of turbine engine-powered, large transport category airplanes provide flightcrews with data from which the lowest V_1 speed complying with specified takeoff criteria can be determined.

On February 26, 1986, the FAA informed the Safety Board that it has commenced rulemaking activity in response to these recommendations. If adopted, the final rule will satisfy, in part, the intent of the recommendations. As a result, the Safety Board has classified the recommendations as "Open--Acceptable Action." The Safety Board is concerned, however, about the time that has elapsed since these recommendations were issued and urges to FAA to expedite the promulgation of a final rule.

The Safety Board also believes that air carriers should provide flightcrew members with the necessary information to allow them to increase the V_1 stopping distance margin without incurring substantial costs. For

¹⁹ Special Investigation Report--"Large Airplane Operations on Contaminated Runways" (NTSB/SIR-83/02).

example, information on the maximum permissible takeoff weight for an available runway, at the existing conditions, would enable pilots to compare the maximum weight with the actual airplane takeoff weight. By selecting the runway that allows for the greatest difference between the two weights, other conditions being equal, pilots can select the runways with the maximum stopping distance available in the event of a high speed RTO. Information that would enable pilots to select the optimum flap configuration for takeoff would also provide the greatest runway distance available for stopping the airplane.

In addition, airlines generally advise pilots to use thrust settings on takeoff that are less than the available maximum thrust whenever feasible. The lower thrust setting helps to prolong engine life. However, the use of the lower or derated thrust settings reduces the runway distance available to stop the airplane. Airlines should be certain that flightcrew members have sufficient information to use derated thrust judiciously without compromising RTO safety margins.

PILOT TRAINING IN RTOS

The requirements of 14 CFR 121, Appendixes E and F, stipulate that pilots of transport category airplanes be presented with "a simulated failure of the most critical engine" either just before or just after V_1 . The regulations require pilots to demonstrate their ability, at regular intervals, to correctly assess whether an RTO is called for, and if an RTO is considered necessary, to perform one effectively.

Written Guidance and Procedures

Airlines operating under 14 CFR 121 provide their pilots in ground school with information on company general operating procedures and on the particular airplane they will operate. Procedures identifying the crewmember authorized to initiate an RTO are stated within company general operating procedures, and are normally reiterated in manuals or handbooks that flightcrew members are required to master.

For all but one airline the Safety Board observed, the decision to reject the takeoff, regardless of which crewmember is flying the airplane, is the captain's alone. Continental Airlines allows first officers, under certain conditions, to make the decision to initiate an RTO; however, the captain remains responsible for the proper completion of the RTO.

Should a high speed RTO be necessary, the airlines emphasize the use of all deceleration devices available on the airplane, including reverse thrust, ground spoilers, and wheel braking. In addition, crewmembers are assigned specific tasks and are generally required to make certain callouts when initiating an RTO. For example, Delta Air Lines' L-1011 Pilots Reference Manual states that when the first officer is making the takeoff:

...if the Captain decides that a situation warrants an abort (or RTO), the Captain will so state and in a positive manner assume control of the aircraft....The Captain should announce his intentions.

Despite these procedures and Delta's training, information from the cockpit voice recorder on Delta flight 23 (described in the section "Previous RTO Incidents and Accidents") indicates that the RTO was initiated after V_2 and that the captain did not announce he was rejecting the takeoff. Rather, the captain says "pull 'em" three times. After the sound of engine deceleration is heard, the first officer says "going to abort" followed by the flight engineer's call for "abort checklist."

The airlines surveyed by the Safety Board have generally instructed their pilots to execute high speed RTOs only in the event of engine fires or failures and only before V_1 . For example, Delta Air Lines' L-1011 Pilots Reference Manual requires that the "abort decision be made and appropriate procedures initiated" only in situations so serious that they "outweigh the risk to the airplane and occupants that a high speed RTO would impose." According to the cockpit voice recorder, the first officer on Delta flight 23 said, "We started to rotate, I got to about seven or eight degrees, from what the engineer saw, ah we got pop-pop-pop-pop-pop, we got guys on final said fire right [engine], fire out of the right hand side of the engine...." Further, he said there was "no engine indication" of thrust difficulties.

The DC-9 Flight Handbook of Midway Airlines directs pilots to "normally continue the takeoff" should a tire failure occur 20 knots or less below V_1 . Further, the airline disseminates the following information to their pilots during ground school:

The speeds given in the FAA Approved Airplane Flight Manual have been selected so that...a stop may be made on the runway at V_1 , without the aid of reverse thrust; and without, in either case, exceeding the FAA takeoff field length. These minimum takeoff field lengths are based on stopping if engine failure is recognized before reaching V_1 , and on continuing the takeoff if engine failure is recognized after V_1 .

Because the minimal stopping distance margins provided for RTOs in the certification process are minimal, if a precipitating event occurs near V_1 and the pilot's initiation of the RTO is not immediate, the stopping distance of the airplane may exceed the amount of runway remaining, even though the runway length met the predetermined accelerate-stop distance for the given conditions. Yet, the Safety Board's review of airline guidance on RTOs indicates that few airlines give their flightcrews complete information about the margin of safety during a high speed RTO.

Federal Express distributed to all flightcrew members guidance on rejected takeoffs written by one of its DC-10 check airmen (Appendix C). The material conveys to pilots detailed information about airplane performance for high speed RTO certification and on practices to employ to enhance the execution of high speed RTOs.

United Airlines developed a videotape as part of its efforts to enhance flightcrew situational awareness of airplane stopping capabilities following high speed RTOs. The video addresses RTO-related certification requirements, presents information on factors that were not considered in the determination of accelerate-stop distances (information about which pilots may not be aware) provides guidance for determining whether to execute an RTO and discusses procedures to follow in the execution of high speed RTOs. The airline mailed the video cassettes to the home of each captain.

Despite the special efforts of airlines such as Federal Express and United, the Safety Board's review of airline guidance and procedures related to RTOs indicates that many airlines do not adequately recognize and address the length of time a pilot needs to assess a situation, to decide whether to initiate an RTO, and to perform the requisite steps to complete the maneuver. Some airlines that the Safety Board surveyed gave flightcrew members incorrect information. For example, one airline describes V_1 in its manual as: "...the decision speed. At this point the pilots must decide whether to continue the takeoff or to abort." Although the definition of V_1 as "the decision speed" is consistent with the FAA definition in 14 CFR 1.2 and in 14 CFR 25.107 (2), the decision to continue or to reject the takeoff should be initiated before V_1 and action must be taken by V_1 for the airplane to be able to be stopped within its predetermined accelerate-stop distance. In addition, some airlines offer vague or ambiguous guidance that gives the flightcrew member little specific information regarding when, in relation to V_1 , the RTO decision should be made or how to make a proper go/no-go decision.

The Safety Board is concerned that some airlines may be conveying misinformation or insufficient information about RTO procedures and airplane stopping capabilities. Therefore, the Safety Board believes that the FAA should require Principal Operations Inspectors to review the accuracy of information on V_1 and RTOs that 14 CFR 121 operators provide to flightcrews to assure that they provide correct information about pilot actions required to maximize the stopping performance of an airplane during a high speed RTO. Further, the Safety Board believes that the FAA should redefine V_1 in 14 CFR 1.2 and 14 CFR 25.107 (2) to clearly convey that it is the takeoff commitment speed and the maximum speed at which RTO action can be initiated to stop the airplane within the accelerate-stop distance.

The Safety Board believes that the guidance airlines provide flightcrew members can and should be modified to include information learned from RTO incidents and accidents. The information can improve pilots' understanding of the dynamics of RTOs, the risks associated with performing high speed RTOs, and as a result, enhance the pilots' ability to correctly decide if an RTO can be safely executed. Consequently, the Safety Board believes that the FAA should require 14 CFR 121 operators to present to flightcrews the conditions upon which flight manual stopping performance data are predicated and include information about those variables that adversely affect stopping performance.

Flight Training

Pilot training in the execution of a high speed RTO is conducted during flight training, almost exclusively in highly sophisticated flight simulators. Simulators vary in the fidelity with which they replicate a particular airplane type, but all visual simulators and the more advanced Phase I, II, and III simulators are required to present visual, aural, and kinesthetic cues that closely match corresponding sensations in the airplane.

Simulator Cues.--Pilot training and checking sessions almost always present RTOs as V_1 , engine failure-related maneuvers. In the sessions, the decision to execute the RTO is based on whether the engine failure occurs just before or just after V_1 . In the RTO training the Safety Board examined, most airlines presented pilots only the cues associated with engine failure. Because the recognition of engine failure and control of the airplane following such an event is a demanding task for pilots, the Safety Board acknowledges that such training should continue.

RTO-related accident and incident data indicate, however, that tire failures lead to more high speed RTOs than do engine-related anomalies. Airlines may not be presenting cues associated with nonengine-related events partly because FAA regulations require that engine failures are to be presented to pilots in their RTO training. The Safety Board's observations suggest that most flight training in RTO recognition and execution is designed to meet and not to exceed the requirements of the Federal Aviation Regulations (FARs). The acquisition and operating costs of flight simulators are high; the costs that airlines may incur by exceeding the minimum flight training and checking requirements and by the salaries of the flight instructors and the students can be substantial. Consequently, most simulated RTOs present only cues associated with engine failure.

Because most RTO training presents only engine failure, pilots may not be fully prepared to recognize cues of other anomalies during takeoff. In addition, the low probability of events occurring that would lead to an RTO increases the likelihood that pilots encountering unusual cues will be experiencing them for the first time. As a result, pilots may be less prepared to react to such cues than they would be had their simulator training also presented nonengine-related cues.

Compounding the difficulty pilots may face in recognizing and reacting to unusual or unique cues is the brief time that elapses between the point at which a transport category turbojet airplane accelerates beyond 100 knots to the point at which it reaches V_1 , generally about 4 to 5 seconds. Should an anomaly occur during this time, the crew will have only a second or two to analyze the event and decide if circumstances warrant an RTO. Consequently, pilots encountering unusual sounds or vibrations just before V_1 may believe it more prudent to reject the takeoff and keep the airplane on the ground than to continue the takeoff.

The British Accidents Investigations Branch (AIB) investigated a 1983 RTO-related accident of a Pan American World Airways, McDonnell Douglas DC-10-30, at London's Heathrow Airport. The high speed RTO was precipitated by a main gear tire failure. The AIB described the difficulty pilots face in such situations:

...in the case of a tire failure or suspected tire failure, the pilot's decision is an extremely difficult one. To assess the extent of the problem when positioned a considerable distance away from the probable source, surrounded by extraneous cockpit noise and vibration and often without any instruments to assist, calls for inspired guesswork aided only by experience. Is the sensory input caused by tire burst or some other problem such as engine breakup? Is more than one tire involved? Is there likely to be any consequential damage, and if so, how serious? Above all, is there a likelihood of fire? These are all questions which the pilot should, ideally, take into account, as well as the aircraft's progress relative to its takeoff speed. To compound his problem, the time available for decision-making is often minimal because tire failures are most likely to occur at high groundspeeds.

The data indicate that pilots often incorrectly interpret the cues accompanying noncritical events (such as simple tire failure) as events threatening the safety of flight; as a result, the pilots incorrectly decide to perform an RTO. The Safety Board believes that presenting flightcrew members with realistic cues accompanying noncritical events will better prepare them to recognize these events should they be encountered during takeoff.

False or Noncritical Warnings.--False or noncritical cockpit warnings have activated as an airplane was approaching, or had reached V_1 , and have lead to a high speed RTO that resulted in an accident or incident. Recent examples include the 1988 accident of American Airlines DC-10 at Dallas-Fort Worth International Airport in which a slat disagree light incorrectly illuminated at or near V_1 , and the 1989 incident of a Delta Air Lines L-1011 TriStar incident at Frankfurt, Federal Republic of Germany, in which the crew heard unusual sounds later found to be caused by a loose boroscope plug in the engine, not engine failure. Another RTO-related accident occurred in 1988 when an Air France Boeing 747-200 overran the runway at Delhi, India; the RTO was initiated after a fire warning sounded at or after V_1 . The warning sounded not because of fire but because a crack in the mid-frame of the No. 4 engine's turbine caused an overtemperature near an engine heat sensor.

In response to the number of false warnings, manufacturers have incorporated into newer airplanes, such as the Boeing 757, 767 and 747-400, and the Airbus A-320, an internal system logic that inhibits all but the most important warnings just before and just after rotation. In the newer model Boeing airplanes, warnings are inhibited after 80 knots and remain inhibited until the airplane has reached 400 feet above ground level or until 20 seconds have elapsed since rotation. The systems on these airplanes

inhibit one of the most critical alerts, the fire warning, which has both auditory and visual components. Should an engine fire be sensed, the engine indicating and crew alerting system (EICAS) will display the fire warning, but the associated fire warning bell will not sound until 20 seconds after rotation has begun or until the airplane has climbed to 400 feet above ground level. Clearly, the inhibition of such warnings substantially reduces the probability that a high speed RTO will be initiated incorrectly. The Safety Board believes that this design feature is a major enhancement to flight safety.

However, most airplanes operating in revenue service today and those that will operate in the near future do not have such systems and cannot reasonably be redesigned or retrofitted to incorporate them. The Safety Board is concerned that without changes in pilot training, pilots may continue to initiate high speed RTOs in response to warnings in the older model airplanes that may be false, noncritical, or both. One practical solution is to introduce in simulator training the specific alerts and warnings that may occur during the takeoff roll, but for which an RTO should not be initiated after a particular speed has been achieved. Such training may provide pilots with the necessary familiarity with warnings so that should a false or noncritical warning or alert occur during takeoff, the pilots can better recognize the need to continue the takeoff. Consequently, the Safety Board believes that the FAA should require that simulator training for flightcrews of 14 CFR 121 operators present, to the extent possible, the cues and cockpit warnings of occurrences, other than engine failures, that have frequently resulted in high speed RTOs.

Takeoff Scenarios.--The Safety Board's observation of RTO-related flight training has revealed that some airlines may be using takeoff scenarios in which the simulator can be stopped with runway distance remaining, even though the pilot's execution of the RTO may not be optimal. The Safety Board believes that RTO scenarios should simulate the most critical conditions and that the airplane should fail to stop on the runway unless the pilot responds as necessary. Without such a scenario, pilots may inadvertently learn that an airplane can stop on a runway in a shorter distance and with greater ability than is true under actual operating conditions; as a result, their decisionmaking regarding RTOs and the execution of the RTOs may be improper. The Safety Board believes that flight simulators should present, as accurately as possible, the airplane's stopping capabilities under all conditions. Consequently, the Safety Board urges the FAA to require that simulator training of 14 CFR 121 operators present accurately the stopping distance margin available for an RTO initiated near or at V_1 on runways where the distance equals or just exceeds balanced field conditions.

CREW COORDINATION IN PERFORMING RTOS

The data indicate that in many of the RTO-related incidents or accidents, the first officer was the pilot flying. These data suggest that a delay may have occurred when control of the airplane was transferred from the first officer to the captain, the crewmember authorized by most airlines to initiate an RTO. The transfer of control involves engine thrust and the

control stick, which require hand input, and the wheel brakes and rudder, which require leg and feet input. Difficulties in transferring control are illustrated by four recent incidents and accidents described earlier in this report: the Air France Boeing 747 in Delhi, India; the American Airlines DC-10 at Dallas-Fort Worth International Airport; the Eastern Airlines Boeing 757 at San Jose, Costa Rica; and the Delta Airlines Lockheed L-1011 TriStar at Frankfurt, Federal Republic of Germany. Other RTO-related accidents and incidents have occurred during the past 20 years that also reveal difficulties in transferring control in RTO execution from the first officer to the captain.

Without effective crew coordination, valuable time may be lost in the transfer of flight control from the first officer to the captain. The Safety Board believes these accidents and incidents illustrate the need to modify existing pilot training and procedures regarding crew coordination during the execution of RTOs. As a result, the Safety Board urges the FAA to require that simulator training for flightcrews of 14 CFR 121 operators emphasize crew coordination during RTOs, particularly those RTOs that require transfer of control from the first officer to the captain.

Some foreign carriers have established policies to preclude difficulties in the transfer of flight control during an RTO. One policy precludes the first officer from performing takeoffs; this policy may limit possible adverse consequences during an RTO, but it may also limit the experience that a first officer could gain from performing takeoffs repeatedly. The Safety Board has investigated accidents that, although not RTO-related, occurred after a relatively inexperienced first officer performed a takeoff under adverse weather conditions.²⁰ As a result, the Safety Board recommends that the FAA require 14 CFR 121 operators to review their policies which permit first officers to perform takeoffs on contaminated runways and runways that provide minimal RTO stopping distance margins, and encourage the operators to revise those policies as necessary.

CALLOUTS

The Safety Board's review of airline procedures revealed general consistency among the airlines surveyed in the manner in which they require that RTOs be performed. Most airlines require callouts for engine or thrust settings, a speed callout such as "airspeed alive," then callouts for V_1 , V_r ,²¹ and V_2 . However, the Safety Board found variation among airlines in the callouts required during takeoffs, particularly during rejected takeoffs. For example, most, but not all airlines, require the nonflying pilot to make a speed callout at 80 or at 100 knots.

²⁰ (a) Aircraft Accident Report--"Continental Airlines, Inc., Flight 1712, McDonnell-Douglas DC-9-14, N626TX, Stapleton International Airport, Denver, Colorado, November 15, 1987" (NTSB/AAR-88/09). (b) Aircraft Accident Report--"AVAir Inc., Flight 3378, Fairchild Metro III, SA227 AC, N622AV, Cary, North Carolina, February 19, 1988" (NTSB/AAR-88/10).

²¹ v_r is the rotation speed.

The speed callout can alert crewmembers to check their air speed indicators for reliability. The callout also indicates that the airplane is entering the high speed takeoff regime. A callout at that speed alerts the crew that the airplane's stopping capabilities have been diminished; at that speed, only engine-related anomalies or events that jeopardize the safety of flight justify initiating an RTO. Without such a callout, the crew may be unaware that the airplane has entered the high speed regime; as a result, the pilot may initiate an RTO at a speed exceeding the airplane's ability to stop on the remaining runway.

The Safety Board also found that most but not all airlines require the pilot initiating the RTO to make an appropriate callout to the other pilot. The investigation of the accident involving the Eastern Airlines Boeing 757 in Costa Rica indicated that the first officer, the flying pilot, was attempting to continue the takeoff while the captain, the only crewmember Eastern authorized to initiate an RTO, was attempting to execute an RTO. The captain made no statement to the first officer to indicate that an RTO was in progress or that he was taking control of the airplane. The accident illustrates the need for the crewmember initiating the RTO to state the intention to the other flightcrew members. Therefore, the Safety Board recommends that the FAA require that the takeoff procedures of 14 CFR 121 operators are standardized among their airplane types to the extent possible, and that the procedures include appropriate callouts to alert flightcrew members clearly and unambiguously when the airplane is entering the high speed takeoff regime and when an RTO is being initiated.

AUTOBRAKES

Many airplanes in service today, such as the McDonnell Douglas MD 80 series and MD 11, the Boeing 757 and 767, and the Airbus series, have been equipped with braking systems known as autobrakes. Autobrakes automatically establish wheel braking upon landing or upon a predetermined throttle reduction once past a certain speed during takeoff. As a result, pilot input is not required to initiate braking action on the airplane wheels. The extent of brake forces can vary from light to heavy pressure on landings, but for RTOs, autobrakes automatically apply maximum brake pressure.

The requirement for setting autobrakes to the RTO mode varies among operators. Some airlines believe that determination of autobrake setting should be left to the captain based on his or her experience. For example, at USAir, autobrake setting during takeoff was a pilot option; on USAir flight 5050 (a Boeing 737-400), which ran off the runway at LaGuardia Airport in New York City in September 1989, the autobrakes had not been set. The Safety Board's investigation of the accident is continuing; the utility of autobrakes in that accident has yet to be determined. However, the Safety Board believes that airlines should require that autobrakes, when available, should be set in the RTO mode when conditions warrant; for example, on a contaminated runway or when the runway length is not substantially greater than the balanced field length. The Safety Board recognizes that pilot discretion should be permitted in the setting of autobrakes under certain takeoff conditions, yet, the Safety Board also believes that the use of autobrakes should be required when warranted. Therefore, the Safety Board

urges the FAA to require 14 CFR 121 operators to require pilots to adopt a policy to use the maximum brake capability of autobrake systems, when installed on the airplane, for all takeoffs in which minimum stopping distances are available following a rejected takeoff.

The Safety Board also believes that flight training for pilots of airplanes not equipped with autobrakes should emphasize the need for flightcrew members to prepare for maximum braking during takeoffs. Such preparation requires that the pilot responsible for initiating an RTO have his or her feet in position to exert maximum brake pressure as soon as an RTO is initiated. The Safety Board's observation of procedures and training in RTO execution indicates that airlines emphasize the importance of throttle movement by requiring that the pilot authorized to initiate an RTO will place his or her hands on the throttles at some point during the takeoff; for most airlines, the hands are to remain on the throttles until V_1 is reached. Should an RTO be initiated, the pilot can then reduce the thrust to idle and institute reverse thrust almost immediately. However, foot placement is not generally addressed, and unless the pilot's feet are in the proper position, valuable time may be lost before maximum braking can be achieved.

During an actual or simulated RTO, a pilot may exert what he or she believes to be maximum braking pressure, only to learn afterwards that maximum pressure was not achieved. Many flight simulators have the ability to record various braking parameters; airlines with such simulators can provide their pilots information on the extent to which they exerted maximum brake pressure and the amount of time needed to achieve the maximum pressure. The Safety Board encourages airlines to modify their training and procedures to emphasize the importance of proper foot placement during takeoffs and to provide information to pilots, when possible, on the maximum brake pressure achieved during a simulated rejected takeoff and the amount of time needed to achieve that pressure.

RECOMMENDATIONS

As a result of this special investigation, the National Transportation Safety Board recommends that the Federal Aviation Administration:

Redefine V_1 in 14 CFR 1.2 and 14 CFR 25.107 (2) to clearly convey that it is the takeoff commitment speed and the maximum speed at which rejected takeoff action can be initiated to stop the airplane within the accelerate-stop distance. (Class II, Priority Action)(A-90-40)

Require Principal Operations Inspectors to review the accuracy of information on V_1 and rejected takeoffs that 14 CFR 121 operators provide to flightcrews to assure that they provide correct information about pilot actions required to maximize the stopping performance of an airplane during a high speed rejected takeoff. (Class II, Priority Action)(A-90-41)

Require 14 CFR 121 operators to present to flightcrews the conditions upon which flight manual stopping performance is predicated and include information about those factors which adversely affect stopping performance. (Class II, Priority Action)(A-90-42)

Require that simulator training for flightcrews of 14 CFR 121 operators present, to the extent possible, the cues and cockpit warnings of occurrences other than engine failures that have frequently resulted in high speed rejected takeoffs. (Class II, Priority Action)(A-90-43)

Require that simulator training of 14 CFR 121 operators present accurately the stopping distance margin available for a rejected takeoff initiated near or at V_1 on runways where the distance equals or just exceeds balanced field conditions. (Class II, Priority Action)(A-90-44)

Require that simulator training for flightcrews of 14 CFR 121 operators emphasize crew coordination during rejected takeoffs, particularly those rejected takeoffs that require transfer of control from the first officer to the captain. (Class II, Priority Action)(A-90-45)

Require 14 CFR 121 operators to review their policies which permit first officers to perform takeoffs on contaminated runways and runways that provide minimal rejected takeoff stopping distance margins, and encourage the operators to revise those policies as necessary. (Class II, Priority Action)(A-90-46)

Require that the takeoff procedures of 14 CFR 121 operators are standardized among their airplane types to the extent possible, and that the procedures include appropriate callouts to alert flightcrew members clearly and unambiguously when the airplane is entering the high speed takeoff regime and when a rejected takeoff is being initiated. (Class II, Priority Action)(A-90-47)

Require 14 CFR 121 operators to require pilots to adopt a policy to use the maximum brake capability of autobrake systems, when installed on the airplane, for all takeoffs in which runway conditions warrant and where minimum stopping distances are available following a rejected takeoff. (Class II, Priority Action)(A-90-48)

BY THE NATIONAL TRANSPORTATION SAFETY BOARD

/s/ James L. Kolstad
Chairman

/s/ Susan M. Coughlin
Acting Vice Chairman

/s/ John K. Lauber
Member

/s/ Jim Burnett
Member

February 27, 1990

(This page intentionally left blank)

APPENDIX A
ACKNOWLEDGMENTS

The Safety Board thanks the following individuals and organizations who assisted in this study:

Midway Airlines
Capt Ross Hutchinson
Director of Training and Technical Services

Federal Express
Mr. Kenneth Ennslin
Senior Manager, Flight Safety - Flight Operations

Captain Michael Hazelwood
Chief Flight Instructor

Trans World Airlines, Inc.
Captain L. Clark Billie
Vice President, Engineering and Operations Control

Captain William E. Pope
Manager, Flight Instruction Standards

Mr. Richard F. Fagan
Flight Manager, Training

Pan American World Airways, Inc.
Captain Roy E. Butler
System Director, Flight Training

Captain Britt Williams
Director, Flight Training-Boeing 727/737/747

Captain Jim Anderson
Director, Flight Training
Airbus A300/A310

Delta Airlines
Captain Douglas D. Twinam
Staff Manager Technical, Flight Standards

APPENDIX A

American Airlines
Captain William H. Syblon
Manager, Special Projects

Southwest Airlines
Captain Dan Jenkins
Director of Flight Training

Captain Don Harbour
Senior Simulator Flight Instructor

Continental Airlines
Captain William J. Nogues
Director of Flight Standards and Training

Captain Roy W. Doby
Manager, Pilot Training

Captain John R. Brooke
Boeing 727 Program Manager, Flight Standards and Training

United Airlines
Mr. Lew Kosich
Boeing 757/767 Training Check Airman
Chairman, ATA Flight Operations Review Team

Captain Bob Morton
Manager of Flight Standards and Training

APPENDIX B

TWA FLIGHT DATA SHEET FOR JFK'S RUNWAY 4L

NEW YORK, NEW YORK
KENNEDY INT'L
JFK

3/30/88 R

747-100/200 AIRCRAFT PERFORMANCE
TRANS WORLD AIRLINES

INTERSECTION	747-100/200		TAKEOFF PERFORMANCE DATA		AC PASSENGERS OFF
	<p>JFK 4L 747 J796-TA OFF DRY 30 POS FLAPS LENGTH 11351. ELEV 12. GRAB 0-0 OBSACLE LIMITED</p> <p>4L V1 _____ V2 _____ Vr _____ Vn _____ TRANSITION ALT _____ Vmax STANDARD _____ MAXIMUM _____ EPR _____ N1% _____ INITIAL STAB _____ CLIMB N1 _____ % TRIM _____ TEMP _____ °F _____ °C ALTM _____ WIND _____ -ELEV _____ PERF TEMP _____ STA PR _____ RWY ZERO WIND _____ PERFORMANCE ADJ(±) _____ ADJ RWY ZERO WIND _____ RWY WIND ADJ(±) _____ RWY LIMIT WT _____ ASI/SLUSH ADJ(-) _____ ASI/SLUSH MAX WT _____ STRUCT/CLIMB _____ MAX TAKEOFF WT _____ ACTUAL WT _____ LDG WT _____ GA EPR _____ TRANS LEVEL _____ ATIS _____</p>				
DO NOT EXCEED STRUCTURAL LIMIT WEIGHT		747-100	747-200		
DO NOT EXCEED STRUCTURAL LIMIT WEIGHT		734,000	775,000		

INTERSECTION

747-100/200

TAKEOFF PERFORMANCE DATA

AC PASSENGERS OFF	747-100/200		TAKEOFF PERFORMANCE DATA		AC PASSENGERS OFF
	<p>JFK 4L 747 J796-TA OFF DRY 30 POS FLAPS LENGTH 11351. ELEV 12. GRAB 0-0 OBSACLE LIMITED</p> <p>4L V1 _____ V2 _____ Vr _____ Vn _____ TRANSITION ALT _____ Vmax STANDARD _____ MAXIMUM _____ EPR _____ N1% _____ INITIAL STAB _____ CLIMB N1 _____ % TRIM _____ TEMP _____ °F _____ °C ALTM _____ WIND _____ -ELEV _____ PERF TEMP _____ STA PR _____ RWY ZERO WIND _____ PERFORMANCE ADJ(±) _____ ADJ RWY ZERO WIND _____ RWY WIND ADJ(±) _____ RWY LIMIT WT _____ ASI/SLUSH ADJ(-) _____ ASI/SLUSH MAX WT _____ STRUCT/CLIMB _____ MAX TAKEOFF WT _____ ACTUAL WT _____ LDG WT _____ GA EPR _____ TRANS LEVEL _____ ATIS _____</p>				
DO NOT EXCEED STRUCTURAL LIMIT WEIGHT		747-100	747-200		
DO NOT EXCEED STRUCTURAL LIMIT WEIGHT		734,000	775,000		

AC PASSENGERS OFF	747-100/200		TAKEOFF PERFORMANCE DATA		AC PASSENGERS OFF
	<p>JFK 4L 747 J796-TA OFF DRY 30 POS FLAPS LENGTH 11351. ELEV 12. GRAB 0-0 OBSACLE LIMITED</p> <p>4L V1 _____ V2 _____ Vr _____ Vn _____ TRANSITION ALT _____ Vmax STANDARD _____ MAXIMUM _____ EPR _____ N1% _____ INITIAL STAB _____ CLIMB N1 _____ % TRIM _____ TEMP _____ °F _____ °C ALTM _____ WIND _____ -ELEV _____ PERF TEMP _____ STA PR _____ RWY ZERO WIND _____ PERFORMANCE ADJ(±) _____ ADJ RWY ZERO WIND _____ RWY WIND ADJ(±) _____ RWY LIMIT WT _____ ASI/SLUSH ADJ(-) _____ ASI/SLUSH MAX WT _____ STRUCT/CLIMB _____ MAX TAKEOFF WT _____ ACTUAL WT _____ LDG WT _____ GA EPR _____ TRANS LEVEL _____ ATIS _____</p>				
DO NOT EXCEED STRUCTURAL LIMIT WEIGHT		747-100	747-200		
DO NOT EXCEED STRUCTURAL LIMIT WEIGHT		734,000	775,000		

AC PASSENGERS OFF	747-100/200		TAKEOFF PERFORMANCE DATA		AC PASSENGERS OFF
	<p>JFK 4L 747 J796-TA OFF DRY 30 POS FLAPS LENGTH 11351. ELEV 12. GRAB 0-0 OBSACLE LIMITED</p> <p>4L V1 _____ V2 _____ Vr _____ Vn _____ TRANSITION ALT _____ Vmax STANDARD _____ MAXIMUM _____ EPR _____ N1% _____ INITIAL STAB _____ CLIMB N1 _____ % TRIM _____ TEMP _____ °F _____ °C ALTM _____ WIND _____ -ELEV _____ PERF TEMP _____ STA PR _____ RWY ZERO WIND _____ PERFORMANCE ADJ(±) _____ ADJ RWY ZERO WIND _____ RWY WIND ADJ(±) _____ RWY LIMIT WT _____ ASI/SLUSH ADJ(-) _____ ASI/SLUSH MAX WT _____ STRUCT/CLIMB _____ MAX TAKEOFF WT _____ ACTUAL WT _____ LDG WT _____ GA EPR _____ TRANS LEVEL _____ ATIS _____</p>				
DO NOT EXCEED STRUCTURAL LIMIT WEIGHT		747-100	747-200		
DO NOT EXCEED STRUCTURAL LIMIT WEIGHT		734,000	775,000		

(This page intentionally left blank)

APPENDIX C

FEDERAL EXPRESS HANDOUT ON REJECTED TAKEOFFS



INTER-OFFICE MEMORANDUM

DATE: April 27, 1988 TO: All Crewmembers
FROM: Rick Myers cc: Frank Fato
SUBJECT: REJECTED TAKEOFFS Jerry Hogue
Ron Keller
Jack Miller

Much has been published over the last few years concerning rejected takeoffs. Some of the concerns relate to the criteria upon which RTO certification is based (during original airplane flight testing for it's type certificate) versus how RTO's might manifest themselves in line flying.

Captain John D. Whitehead, DC-10/Check Airman, has devoted a lot of his personal time to this paper. He has taken several articles on this subject and pulled out references that he feels will cut through some of the engineering type talk (while keeping the necessary background information) and get to the points of interest of the line pilot.

I hope you will agree that this is good food for thought. Please take the time to look over this material and discuss it with your fellow pilots.

Thank you for your attention,

A handwritten signature in cursive script that reads "Rick Myers". The signature is written in black ink and is positioned above a horizontal line.

Captain Rick Myers
Senior Manager/Pilot Training
Chief Flight Instructor
Extension: 222-6364
Comat: 3211

RM:mlj:3336v

APPENDIX C

REJECTED TAKEOFFS

I'm sure you're all aware that V1 is the GO/NO-GO speed for takeoffs, right? **WRONG!** Thrust reversers are a good "pad" in RTO's since they aren't considered in rejected takeoff demonstrations for certification, right? **NOT ALWAYS!**

A good place to start is with some background into transport category certification standards from an paper entitled **V1 REJECT**. The paper was presented at a safety seminar entitled Safety Focus.

V1 REJECT

V1 Speed

V1 speed is not "engine failure speed". V1 is "engine failure recognition speed". On all current jet aircraft, the critical engine is assumed to have failed below V1 at a speed called Vef. The crew is assumed to have recognized and initiated a response to the engine failure by V1 speed. V1 is not the speed at which failure can occur and begin the recognition-decision-reaction sequence. At V1 speed the crew must already be moving rapidly into a vigorous effort to stop the aircraft.

The certification process for present jets was accomplished when V1 was defined by the FAA and understood by the pilots to mean "engine failure speed". After numerous dramatic failures in rejected takeoffs, the FAA rewrote the regulations to define engine failure speed as Vef and to define V1 as "engine failure recognition speed" to legitimize the procedure. This new rule, adopted in 1978, also requires time delays and engine-out acceleration recognition. No corrective safety margin has been applied to our aircraft certified under the pre-1978 rule to compensate for this change. The FAA does not even require an allowance for runway lost in positioning the aircraft for takeoff.

Certification

The certification scenario works like this; a crew, rested, steely-eyed, iron pumping, racquetball champion, graduate from test pilot school, lashed himself into the left seat of a brand new flying machine. The flying machine has sparkly cold brakes and rubber skins with the paper labels still not worn off. The runway is scrubbed bare and dry for all 15,000 feet. The sky is cloudless, the air is cool, and the wind is right down the runway at zero knots.

Our hero has been programed, by a multitude of practice runs in the simulator, to reject on a given signal that he knows is coming. This he does, Gretzky style, with his hands and feet just

a blur as he swings into action. As a matter of fact, the aircraft certification is based on the following time intervals demonstrated by Joe Cool: from engine failure to brake application (recognition-reaction time) 0.35 sec. (Yes, that's right, less than half a second!), 0.48 sec. more to throttle chop and 0.61 sec. to spoiler activation. Another 2 sec. generously added in to a total of 3.44 sec. for the certification.

This Alice-in-Wonderland situation is seldom duplicated by Capt. Flatspin Fumble, your average line driver. As a point of interest, Capt. Fumble, according to a NASA/Douglas simulator test, can only achieve maximum braking during simulator RTO's, 60% of the time.

Tires, Wheels, & Brakes

To further compound the problem, an FAA study determined that 87% of rejected takeoffs were caused by tire, wheel, and brake failures. Douglas estimated the figure at around 50%. Yet, critically, these components are required to be 100% effective to achieve the scheduled stopping distance.

Tire manufacturing standards are suspect in many of the tire failure situations. The FAA revised the 1962 ESO (TS062C) to increase the load bearing capacity of aircraft tires, but just up to existing standards set by the manufacturers. A further 1979 NPRM to further increase strength and rate load has been initially rejected by the carriers as being too costly. Just recently, new tire standards are gradually taking effect.

Weather Conditions

The certification process does not take crosswind effects on aircraft performance into consideration. Aileron and spoiler drag as well as displaced rudder drag will increase the distance covered to reach VI speed.

It is generally conceded that a wet runway gives approximately one-half the braking coefficient of a dry runway.

There are also documented instances of extensive differences between reported airport temperature and runway surface temperature in a calm wind. Aerodynamic and engine propulsive performance can be greatly reduced from the planned due to this factor alone.

Takeoff Alignment Distance

The Australian government is the only certifying authority requiring runway alignment allowance. The opposing factions claim that the scheduled accelerate-stop distance does not take credit for reverse thrust, and this more than compensates for the distance lost in alignment. However, reverse thrust credit is not allowed in certification because the FAA does not consider it to be sufficiently reliable.

Courtesy ACAC via Safety Focus

APPENDIX C

I hope, after reading this safety paper, that you can begin to appreciate what you're up against when you make your next takeoff. Now let's look at each point a little further.

Today's Takeoff

Now let's consider the effects of heat buildup on your tires and brakes as you make that long taxi to the takeoff runway on a hot day. The test airplane began from a standing start with no taxi prior to the takeoff roll and, therefore, no heat buildup. The test airplane's tires were carefully checked to confirm that pressures were exactly as specified by the tire and airplane manufacturers. In contrast, your takeoff today may be the last one before the brake change, or the tire change. Today's takeoff may be the one with rubber deposits at the "reject end" of the runway or the one with water or ice on the runway, each of which may effect your deceleration without constituting clutter and therefore not be accounted for in your takeoff data. (Airplanes operating under British CAA rules must lower V1 speeds on wet runways to allow for degraded stopping performance with a wet runway). Your tire pressures may not have been closely checked by that contract maintenance man assigned to today's charter (the charter that requires you to make a max gross weight takeoff).

In the U.K., it is general policy to undertake performance testing with used tires and 90% worn brakes, in contrast to the FAA practice. The U.K. requirement to stop in a wet demonstration can also be a significant trial variation from U.S. standards. In committee discussion of the U.K. Flight Safety Committee it was argued that performance standards testing, recently updated for new tire designs, should be applied in some similar degree to the typical retread as such a large proportion of the tires used are retreaded. The engine failure definition of V1 is no protection for the tire failure case even with the lately extended pilot recognition and reaction times of the U.K. code. The effect of flat or broken-up tires on braking is gross.(1)

What about those thrust reversers? Since they aren't accounted for during certification testing, shouldn't there be a pad built in to our stopping performance during a RTO? The answer is yes, there is "some" pad, but it is considerably less than you might think. According to a paper by Ronald Ashford of the British CAA, "Poor thrust reversers on some aircraft, for example the 747, are a factor in the runway overrun accident record. Aircraft with good thrust reversers have less than a third of the accidents of those with poor reversers. There are about three a year, of which one is fatal. This is not acceptable and more rational international requirements for stopping on wet runways are needed". Capt. Falko Fruehauf, Lufthansa's manager of performance and operations engineering is quoted as saying, "The influence of reverse thrust is overrated". The use of max symmetrical reverse, in a one-engine inop 4 engine airplane reject, reduces the stopping distance by

400 ft. Just a 10% reduction in runway braking coefficient will cause this advantage to disappear completely. It's no secret that our reversing system on the DC-10 leaves something to be desired.

What Can I Do?

During the preflight, the Second Officer should carefully examine the tire condition including pressures where the gauge is installed in the wheel. While some S/Os might argue as to the accuracy of these gauges, it's the old "something is better than nothing" routine. If there is a large discrepancy between pressure gauges, especially on tires on the same axle, it should be brought to the attention of the Captain and maintenance personnel. Analysis indicates that the predominant cause of tire failure is underinflation and the resultant overdeflection of the tire sidewall. During taxi and takeoff, the heat buildup in the underinflated tire will increase more rapidly while the higher-pressure tire will be carrying a greater portion of the load. Both reduce the safety margin.(2)

Don't Taxi Fast

The heat buildup due to flexing of the sidewalls while the tire is rolling can be influenced by taxi techniques. Due to the low heat conductivity of rubber, tire temperatures continue to rise while the wheels are rolling. Thus, tire temperatures increase with taxi distance. The temperature rise is also influenced by taxi speed. Don't race to the end of the runway and make a rolling takeoff to beat an approaching airplane on final. Increased tire temperature decreases tire strength which reduces some of the design safety margin during takeoff. Douglas recommends a maximum taxi speed of 20 to 30 knots. Lower taxi speeds should be used at high gross weights and/or for long taxi distances. Avoiding high taxi speeds is, by far, the most effective way to keep heat buildup out of tires. Riding the brakes (continuous light application) to control taxi speed will heat the brakes faster than momentary, moderate application to reduce speed followed by complete release of the brakes and allowing the airplane to accelerate before another brake application. In addition, avoid sharp turns where possible. When making tight turns, avoid the use of brakes on the inside wheels.(3)

What Justifies a RTO?

That is the \$64,000 question. While no two circumstances will be exactly alike, there are some considerations to look at. Pilots have come to regard V1 as the GO/NO-GO decision speed for any recognized anomaly during the takeoff roll regardless of other favorable factors such as excess runway over that required, all engines operating, etc. Most airplane manufacturers and many of the world's major airlines have begun to adopt the approach that the

APPENDIX C

decision to reject a takeoff should be based on an increasing level of criticality as the airplane approaches V1. One consideration suggested by both NASA and Douglas would be that when takeoff speeds are between 20kts. below V1 and V1, only an engine failure could cause the initiation of a RTO. Tire failures and other less serious anomalies would not automatically prompt a RTO. This addresses the situation where tire problems manifest themselves just prior to or at V1 which may compromise the ability to stop within the available runway remaining. Mr. H.H. Knickerbocker of McDonnell Douglas has written "It is imprudent to put the full weight of an aircraft loaded for takeoff, plus the stress of a high-speed maximum braking effort abort, on an already damaged tire system. The only high-speed tire problem worth aborting for is one that has caused serious engine anomalies".

Japan Air Lines says, "The following type of abnormalities at or near V1 may justify a continued takeoff.

- °Tire failure
- °Antiskid failure
- °Caution light concerning engine failure
- °General electrical failures
- °Indication failure of instruments not absolutely required

British Airways says in their 737 manual,

- °Up to 100kts.abandon for any malfunction
- °100kts. to V1.....abandon only for
 - (a) Engine failure-either thrust guage falling below 80%
 - (b) The Captain observing an emergency and calling 'STOP'
 NOTE: Do not abandon for an engine fire or overheat warning unless accompanied by a loss of thrust.

Boeing says, "Unless the situation which is leading to a GO/NO-GO decision is rapidly assessed as critical to remain on the ground, the chances of success are better by continuing the takeoff and then determining the next course of action under less stressful and time critical conditions".

NOTE: On the newer Boeing jets such as the 767, portions of the crew alerting system that are not critical to the takeoff phase are inhibited after 80kts. and until 20 seconds after liftoff or reaching 400ft.. Additionally, the fire bell and master warning lights are inhibited between nose gear strut extension and either 20 seconds elapsed time or 400ft. Clearly, Boeing has determined that items associated with these particular warnings are not worthy of a RTO.

Lufthansa says, "When comparing the risks of stopping with those of a continued takeoff, one must note that there is an additional safety margin when continuing the takeoff. This additional safety margin is the reason for the superiority of the GO decision compared to the NO-GO decision"

The Reject

*On October 18, 1983, our B-747 freighter D-ABYU departed from Hong Kong Rwy 13 at a takeoff weight of 822,000lbs. It was a field length limited takeoff. The balanced V1 was calculated to be 157kts.

A broken retainer ring in engine #2 resulted in high EGT and later caused N1 to be 11% below target. The decision was made to abort the takeoff very close to V1. The airplane came to rest left of Rwy 13 in soft ground and was considerably damaged. None of the three-man crew was hurt.

In the case of our Hong Kong rejected takeoff, the 4 engine reverse contributed only 460ft. to the stop performance.

A significant aspect of this accident is, however, that the airplane ran off the side of the runway, otherwise there is no doubt that the airplane would have left the end of Rwy 13 when extrapolating the actual speed distance history. The airplane would have crashed into the water of the harbour with serious consequences." (4)

It appears these people were very lucky and apparently skilled in the RTO maneuver itself. A review of crew debriefings when an overrun has taken place reveals that there may be a curious psychological manifestation in the minds of some crew members at the moment of rejecting a takeoff beyond V1 which in some cases almost puts them in the spectator category. The thought seems to be that they are going off the end of the runway and they are sort of along for the ride. Flight data recordings have shown that maximum braking has not been obtained even though the flight crew have testified "full pedal application was used". Full brake pedal application to the stops must be continuously held for the entire deceleration period of the RTO to a complete STOP! Full application of reverse should also be used down to a stop if necessary. As speed decreases below 80kts., there may be a feeling that speed is much lower than actual and that the airplane will surely stop on the remaining runway. At this point there is a tendency to let up slightly on the brakes or start coming out of reverse thrust. Don't fall into this trap. Keep the brakes on full until you have rocked to a stop. Our DC-10 rejected takeoff checklist asks "at what speed was the reject initiated?" so as to determine cool down time. It doesn't ask, "Did the Captain get on the brakes hard or easy?" Going easy on the brakes doesn't save one minute of cool down time so stick with the proven method of bringing the airplane to a complete stop.(5)

In Conclusion

Have you really thought out the reasons for initiating an RTO below, say p100kts. versus just before V1? What will you do if a tire blows at V1 minus 10kts during a light weight takeoff on a long dry runway versus a balanced

APPENDIX C

field length situation with a wet runway? Does your crew know what you are thinking? Flight crew briefings before takeoff should be complete with respect to the greatest potential hazard for that particular takeoff, such as bad weather, critical obstacles, etc. When the takeoff is under runway limited conditions or when the runway is contaminated, an obvious additional candidate subject for a careful pre-takeoff briefing is the RTO maneuver.

In the "real world" many factors are working against you such as weather, wet runways, worn tires and brakes, hot brakes, inoperative systems, and our favorite, crew fatigue.

It is impossible to predict when or how many tires may fail on takeoff, or to anticipate or measure just how wet is wet. In this scientific world, there are still situations in which the Captain must exercise skill and judgement beyond the scope of the book. But, knowledge properly applied can certainly help prevent the need to rely entirely on superior skill.

John D. Whitehead/Mar 1988

- (1) From FLIGHT SAFETY FOCUS, a publication of the U.K. Flight Safety Committee.
- (2) MDC Newsletter Vol. II, #6, August 1978
- (3) MDC Newsletter Vol. II, #8, July 1983
- (4) Lufthansa GO/NO-GO Philosophy
40th Int'l Air Safety Seminar, Tokyo, Japan
- (5) MDC Newsletter #8 and MDC letter to all operators titled Rejected Takeoffs/Overruns,
Dec. 6, 1982
MDC Newsletter Vol. II, #4, August 1977

U.S. DEPARTMENT OF COMMERCE
National Technical Information Service
6285 Port Royal Road
Springfield, VA 22161

OFFICIAL BUSINESS

Penalty for Private Use, \$300

AN EQUAL OPPORTUNITY EMPLOYER

**BULK RATE
POSTAGE & FEES PAID
NTIS
Permit No. G-292**

(This page intentionally left blank)

RTO Accident/Incident List 1959 to 1990

4-B

Introduction for RTO Overrun Accident/Incident Summary

The following table lists the 74 events involving the Western built commercial jet fleet included in the RTO Overrun Accident and Incident Study and are the basis for the statistical analyses presented in Sections 2 and 4. These events include rejected takeoff accidents wherein the airplane was unable to stop on the runway available (i.e. those events associated with runway length). These incident events were reviewed and only the significant ones were included. These were generally relatively high speed overruns which occurred in hospitable surroundings; Had the same event occurred in less hospitable surroundings, the incident would have been an accident. The study did not include events where directional control was lost during the takeoff roll and the airplane departed the runway side boundaries as a result of the loss of control.

Many of these events involved a combination of factors and some are not thoroughly documented by investigation reports. A degree of judgement was sometimes required in identifying a prime RTO decision factor. Users of these data are cautioned that the reason the crew decided to initiate an RTO and the reason their RTO was unsuccessful may be totally unrelated. Few of these events occurred while operating at field length limit weight.

The reader may be aware of additional RTO overrun events (either accidents or incidents) that are not included in this study. If an event does not appear, it is only because there was no record available as of the time of the study. Several RTO overrun accidents were reported after this study was completed. However, because the data base is now large enough to be statistically "stable", the conclusions and recommendations of the study were not affected.

(This page intentionally left blank)

RTO Overrun Accidents/Incidents Summary

	DATE	OPER	A/P TYPE	LOCATION	A/I ¹	RTO INT ² SPEED	CAUSE ³	R/W ⁴ COND
1	011961	AMX	DC8	NEW YORK	A	>V1	CREW COORD	SNOW
2	060362	AFA	707	PARIS	A	>V1	CONFIG	DRY
3	082062	POR	DC8	RIO DE JANEIRO	A	>V1	CONFIG	DRY
4	110663	ACN	DC8	LONDON	A	>V1	CREW COORD	WET
5	112364	TWA	707	ROME	A	<V1	IND/LIGHT	DRY
6	013066	TWA	707	FRANKFURT	A	>V1	CONFIG	DRY
7	100166	VAR	CV990	BOGOTA	I	>V1	TIRES	DRY
8	110567	CAT	CV880	HONG KONG	A	<V1	TIRES	DRY
9	110667	TWA	707	CINCINATTI	A	>V1	CREW COORD	DRY
10	032168	UAL	727	CHICAGO	A	>V1	CONFIG	SNOW
11	080368	DLH	707	FRANKFURT	I	<V1	IND/LIGHT	WET
12	120169	PAA	707	SIDNEY	A	>V1	ENGINE	DRY
13	020970	EGP	CMT	MUNICH	A	>V1		
14	071970	UAL	737	PHILADELPHIA	A	>V1	ENGINE	DRY
15	112770	CIA	DC8	ANCHORAGE	A	>V1	CREW COORD	ICY
16	062371	ONA	DC9	NORTHFORK	I		TIRES	
17	070871	AVI	727	MEDELLIN	I	V1	TIRES	
18	041872	ETH	VC10	ADDIS ABABA	A	>V1	TIRES	DRY
19	071872	BCA	BAC111	CORFU	A	>V1	ENGINE	WET
20	081372	JAT	707	NEW YORK	A	>V1	CREW COORD	DRY
21	091372	TWA	707	SAN FRANCISCO	A	>V1	TIRES	DRY
22	013073	SAS	DC9	OSLO	A	>V1	IND/LIGHT	ICY
23	040373	BRT	737		I		TIRES	
24	012874	COS	720		I		TIRES	
25	082575	AAL	DC10	NEW YORK	A	>V1	TIRES	DRY
26	091575	BAB	TRID	BILBAO	A	>V1	ENGINE	WET
27	111275	ONA	DC10	NEW YORK	A		BIRDS	WET
28	012576	DAL	L1011	DETROIT	I	>V1	ENGINE	
29	111676	TEX	DC9	DENVER	A	>V1	IND/LIGHT	DRY
30	121676	IAL	CV880	MIAMI	A	>V1	CONFIG	
31	011477	CDD	707		I	>V1	IND/LIGHT	SNOW
32	050877	SWS	DC10	ZURICH	I	<V1	ENGINE	WET
33	052577	EAL	727	WASH D.C.	I	>V1	ENGINE	WET
34	030178	CAL	DC10	LOS ANGELES	A	~V1	TIRES	WET
35	050278	CMA	727	MEXICO CITY	I			
36	052578	SEN	CV880	MIAMI	A	>V1	CONFIG	
37	062678	ACN	DC9	TORONTO	A	<V1	TIRES	WET

¹ A = Accident, I = Incident

² RTO Initiation Speed = the speed at which the first action was taken relative to V₁.

³ Cause = the underlying cause of the RTO decision being made.

Engine: Actual, temporary or perceived loss of thrust

Tires: Main or nose gear tire vibration or failure.

Configuration: Incorrect control or high lift surface setting for takeoff.

Indicators/Lights: A reading observed on an indicator or a warning light illuminating.

Crew Coordination: Miscellaneous events where inappropriate crew action resulted in the RTO decision.

Bird Strikes: Crew observed birds along runway and experienced or perceived a subsequent problem.

ATC: ATC or other radio messages caused crew to elect to reject takeoff.

⁴ Runway Condition = reported runway surface condition at the time of the event.

RTO Overrun Accidents/Incidents Summary (Continued)

	DATE	OPER	A/P TYPE	LOCATION	AI ¹	RTO INT ² SPEED	CAUSE ³	R/W ⁴ COND
38	082978	AIN	747	NEW DELHI	I	<V1	ENGINE	DRY
39	112778	NWA	727	MINNEAPOLIS	I	>V1	ENGINE	SNOW
40	121778	IND	737	HYDERABAD	A	>V1	CONFIG	DRY
41	032379	BAL	DC9	ZURICH	I	<V1	BIRDS	WET
42	062479	ARL	737	IBIZA	I		BIRDS	
43	072979	SIA	747	DUBAI	I	<V1	TIRES	DRY
44	100879	BNF	747	HONOLULU	I	V1	ENGINE	DRY
45	032980	MON	CV880	PANAMA CITY	A		TIRES	
46	062480	CPA	737	FORT NELSON	I		BIRDS	
47	081781	PAA	727	FT LAUDERDALE	A	>V1	ENGINE	WET
48	082781	SAA	747	WINDHOEK	I		TIRES	
49	091581	KAL	747	MANILA	A	<V1	ENGINE	DRY
50	020382	UAL	DC10	PHILADELPHIA	A	>V1	ATC ⁵	WET
51	070582	REP	DC9	BOISE	I	>V1	IND/LIGHT	DRY
52	091382	SPN	DC10	MALAGA	A	>V1	TIRES	DRY
53	101883	DLH	747	HONG KONG	A	<V1	ENGINE	DRY
54	112383	DAN	BAE146	BERNE	I			
55	012685	IBE	747	BUENOS AIRES	I	>V1	ENGINE	WET
56	062785	AAL	DC10	SAN JUAN	A	>V1	TIRES	DRY
57	092485	EAL	727	WASH D.C.	I	<V1	ATC	DRY
58	072086	QUE	737	WABUSH	A	>V1	ENGINE	WET
59	081486	IRN	747	HAMBURG	I		CREW COORD	
60	092986	IND	A300	MADRAS	A	>V1	ENGINE	DRY
61	112786	CH6	CVL	ARAUCA	A	>V1		
62	010687	TNS	CVL	STOCKHOLM	A	>V1		
63	022787	ARG	747	BUENOS AIRES	I			
64	080387	CAL	A300	DENVER	I	<V1		
65	052188	AAL	DC10	DALLAS	A	<V1	IND/LIGHT	DRY
66	052388	LAC	727	SAN JOSE (CR)	A	>V1	CONFIG	DRY
67	062888	UNK	BAC111	NEW CASTLE	I		ENGINE	
68	072488	AFA	747	NEW DELHI	A	>V1	ENGINE	DRY
69	111588	USA	DC9	MINNIAPOLIS	I	<V1	TIRES	WET
70	092089	USA	737	NEW YORK	A	>V1	CONFIG	WET
71	051789	SOM	707	NAIROBI	A	>V1		WET
72	081689	LDE	F28	SAN CARLOS	A			SNOW
73	041290	TMP	DC8	BOGOTA	A			
74	072590	ETH	707	ADDIS ABABA	A	>V1	BIRDS	WET

¹ A = Accident, I = Incident

² RTO Initiation Speed = the speed at which the first action was taken relative to V₁.

³ Cause = the underlying cause of the RTO decision being made.

Engine: Actual, temporary or perceived loss of thrust

Tires: Main or nose gear tire vibration or failure.

Configuration: Incorrect control or high lift surface setting for takeoff.

Indicators/Lights: A reading observed on an indicator or a warning light illuminating.

Crew Coordination: Miscellaneous events where inappropriate crew action resulted in the RTO decision.

Bird Strikes: Crew observed birds along runway and experienced or perceived a subsequent problem.

ATC: ATC or other radio messages caused crew to elect to reject takeoff.

⁴ Runway Condition = reported runway surface condition at the time of the event.

⁵ Radio call from a waiting aircraft directed to another aircraft with a similar flight number, mistakenly understood by the accident aircraft.

Other Takeoff Rules

4-C

This appendix contains information on takeoff regulations other than the U.S. FAA rules, which have an impact on takeoff decision making, including United States military takeoff regulations.

It is intended that operators who require additional regulatory coverage contact the manufacturer for model specific information, which can be retained in this appendix for easy reference.

Table of Contents

Chapter	Page
1 U.S. Military Regulations	4-C.1
2 U.K. CAA Regulations	4-C.7
3 Australian CAA Regulations	4-C.9
4 French DGAC Rules	4-C.11
5 Joint Air Regulations (JARs)	4-C.13

The data contained in this appendix is provided for training purposes only and should not be used for any other purpose. Each manufacturer assumes responsibility only for the data which applies to their specific airplane models. Questions regarding any information presented in this appendix should be addressed to the responsible manufacturer.

(This page intentionally left blank)

Chapter 1

U.S. Military Rules Versus FAA Rules

Historically, military services have been the single largest source of airline pilots. Military pilots are generally highly trained and fly in a very structured environment. Military training requires pilots to memorize numerous items including performance definitions. Most lieutenants/ensigns can quote verbatim the definition of the fundamental terms of aircraft performance.

However, when these pilots turn to civil aviation, performance is not always trained to the degree that it is in the military community and the differences between the two worlds is not well defined. This often leads to confusion or the assumption that the two systems are the same. This Appendix will give examples of the fundamental differences between the two systems and illustrate the danger of assuming they are the same.

Line-Up Distance

Under current FAA rules, line-up distance is not required to be taken into account. Military aircraft do. For the C-141B, T.O. 1C-141B-1-1 reads: "Runway available is actual runway length less the aircraft line-up distance. When takeoff EPR is set prior to brake release, subtract 200 feet. When making a rolling or standing takeoff, subtract 400 feet." Other models are less specific, requiring only that the takeoff data be computed based on runway available.

Wet Runway

Under FAA rules, corrections are not required to dry performance numbers when a runway is wet, however some carriers voluntarily make use of manufacturer provided wet runway data. Military manuals use the Runway Condition Reading (RCR) system. Basically, the person calculating the takeoff data either uses the reported RCR or a default value for wet. Again, this value is not standard. The T-43A (737-200 ADV, JT8D-9) uses an RCR of 9 for wet whereas the C-141B uses 12.

V₁ Defined

A precise operational definition of V₁ is difficult to find in the FAR's and there are only a few aircraft types that have been certified in accordance with the latest regulation. As stated on Section 4.3.1.2 of the basic document, "In an operational Field Length Limited context, the correct definition of V₁ consists of two separate concepts:

First, with respect to the 'No-Go' criteria, **V₁ is the maximum speed at which the rejected takeoff maneuver can be initiated and the airplane stopped within the remaining field length under the conditions and procedures defined in the FAR's."**

The certified accelerate-stop distance calculation is based on an engine failure at least one second prior to V_1 . This standard time allowance has been established to allow the line pilot to recognize an engine failure and begin the subsequent sequence of stopping actions. By this definition, V_1 is a limit speed. **It is the latest point in the takeoff roll where a stop can be initiated.**

Second, with respect to the 'Go' criteria, V_1 is also the earliest point from which an engine out takeoff can be continued and the airplane attain a screen height of 35 feet at the end of the runway.

U.S. Air Force - Basic Definitions

In order to adequately discuss the differences between the FAR's and the Mil-Spec, some basic terms must be defined. According to MIL-M-7700D (USAF), "Critical engine failure speed shall be the speed at which the most critical engine can fail and the same distance is required to either continue the takeoff or to stop the aircraft."

It should be noted that the screen height afforded by the FAR's is not included in the Military definition.

"Critical field length shall be the total length of runway required to accelerate with all engines to critical engine failure speed, experience a critical failure, and then continue to takeoff or stop."

"Refusal speed shall be the maximum speed with normal acceleration where a stop may be completed while on the runway."

"Minimum go speed shall be the minimum speed at which an aircraft can experience a failure of the most critical engine and still

takeoff under existing conditions of temperature, pressure altitude, gross weight, and runway remaining. The data are based on an engine failure occurring at minimum go speed and allows for a three second decision period with the remaining engines operating at the initial thrust setting."

Paragraph 3.5.7.5.8.7 (MIL-M-7700D (USAF)) regarding critical field length further states: "The critical field length shall be based on the following rules:

- a. At engine failure speed the aircraft continues to accelerate for 3 seconds with remaining engines at maximum thrust and zero thrust on the inoperative engine.
- b. At the end of the three second acceleration time, thrust on all engines is reduced to idle, brakes applied, and deceleration devices deployed.
- c. Sufficient time will be allowed for deployment of the device or for reverse thrust to build up before including its effects on deceleration."

Note: Reverse thrust credit is not normally taken for takeoffs or landings.

Rejected Takeoff

A graphical comparison of the FAR's versus MIL-M-7700D is seen in Figures 1 and 2.

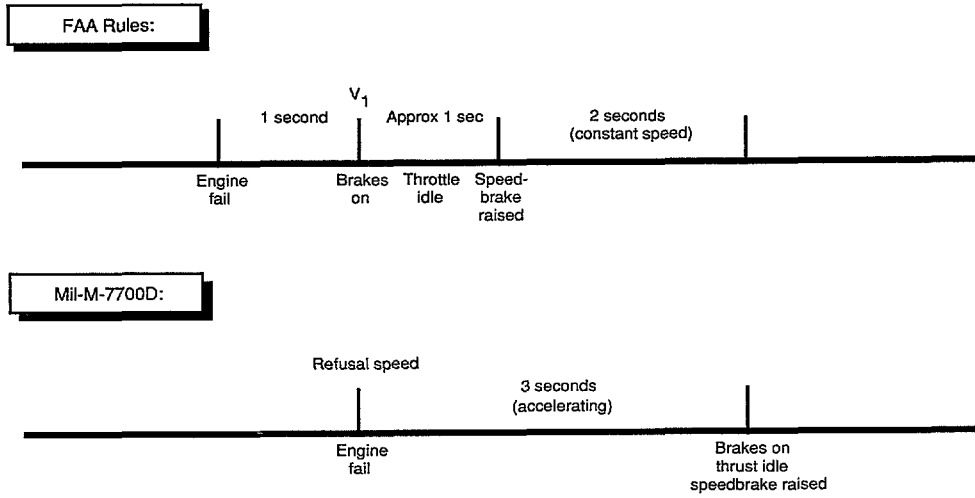

Figure 1

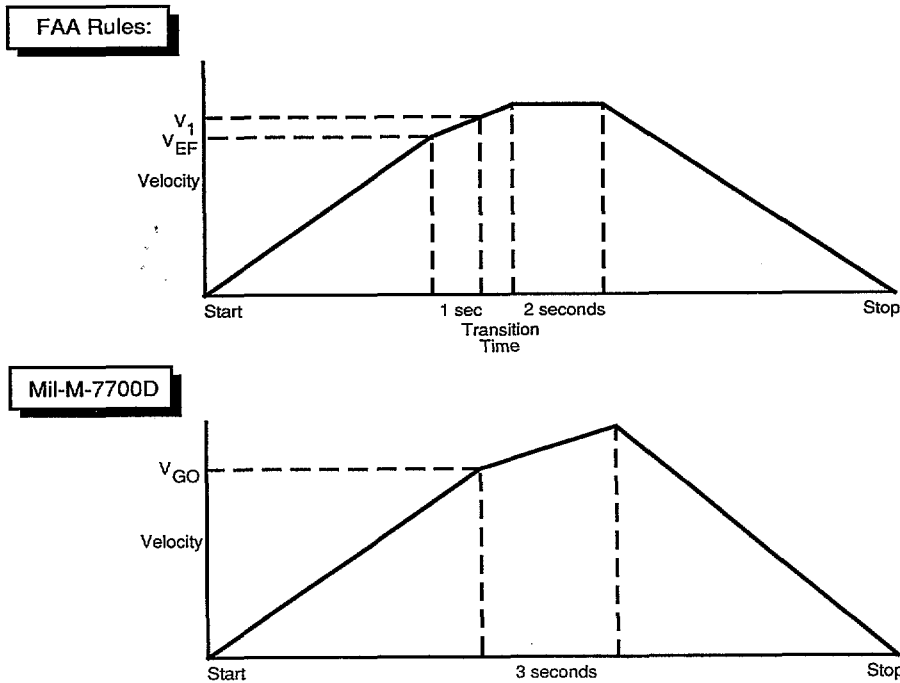

Figure 2

The basis for the T-43A charts as stated in T.O. 1T-43A-1-1 is as follows: "All stopping distances are based on using the takeoff flap setting, spoilers extended manually, no reverse thrust, and maximum anti-skid braking. A 3 second period has been allowed for transition from takeoff thrust to maximum braking."

The way this is described in the C-141B, T.O. 1C-141B-1-1 is: "A five second period has been allowed for transition from takeoff thrust to maximum braking. This allows time to recognize the situation, make a decision to stop and achieve the braking configuration." The statement would indicate that in addition to the three second engine out acceleration time, an additional two second procedure execution time has been added. The 5 seconds is clearly a significant pad compared to the FAR method.

In both the U.S. Air Force and FAA RTO procedures, the pilot should begin action no later than the "Go" speed be it V_1 or VGO, however the consequences of starting the procedure after the "Go" speed in the civilian case when there is no line up distance, no RCR correction and an extremely small stopping pad can be much worse then the case of the Air Force pilot.

Takeoff continued

Figure 3 illustrates the difference between the continued takeoff in the U.S. Air Force versus FAA case.

FAR performance is based on an engine failure 1 second prior to V_1 resulting in a 35 foot height over the end of the runway. A civilian pilot faced with a field length limited balanced field takeoff who experiences an engine failure more than 1 second prior to V_1 and elects to continue the takeoff rather than reject will see a reduction in the height over the end of the runway and over the critical obstacle (if there is one). This is why many commercial airlines today advocate continuing a takeoff once speed is within approximately 10 knots of V_1 unless the airplane is clearly unsafe to fly. The perspective is that there are more pads in the "Go" case than the "Stop" case.

The application of this technique to military aviation is inappropriate. During a critical field length takeoff, the military rules enable an airplane experiencing an engine failure at the "Go" speed to reach takeoff speed at the end of the runway. A critical obstacle is cleared with no margin. A decision to "Go" with an engine failure prior to VGO results in either a low speed rotation or rotating beyond the end of the runway. A critical obstacle will not be cleared.

Figure 3

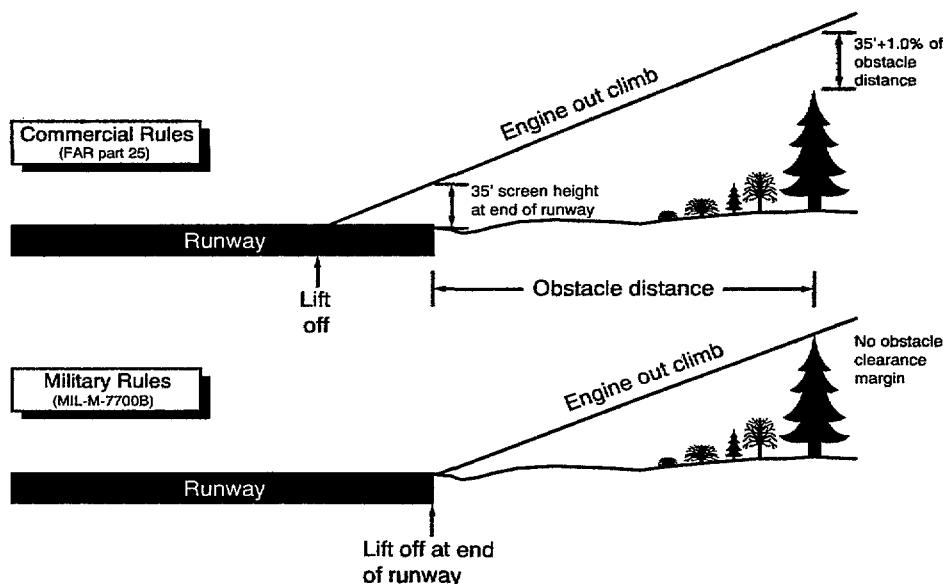

U.S. Naval Aviation

The U.S. Navy is governed by MIL-M-85025A(AS) rather than MIL-M-7700D.

The use of Runway Condition Reading although not identical, is fundamentally the same as the U.S. Air Force.

Some useful definitions are:

Paragraph 3.19.11.2.3d "Minimum Go Speed, V_1 , shall be the minimum airspeed at which the aircraft can experience an engine failure, and then continue to accelerate to, liftoff speed VLOF, within the remaining runway length. The data is based on an engine failure occurring at the Minimum Go Speed. Engine failure is followed by a three second decision period with the remaining engines operating at the initial thrust setting. In the case of an Intermediate thrust takeoff, an additional time period shall be allowed for advancing the operating engine throttles to Maximum Thrust. The time period to be used shall be applicable to the airplane configuration and be approved by the procuring activity. V_1 shall not be less than V_{MCG} , Ground Minimum Control Speed."

Paragraph 3.19.11.2.3g "Maximum Abort Speed, VMAX ABORT, shall be the maximum airspeed at which an abort may be started and the aircraft stopped within the remaining runway length. The data are based on a three second decision period after reaching maximum abort speed, with the engines operating at the initial thrust setting during this time. At the end of the three second decision period, a time period shall be allowed for brake application, and a time delay allowed for movement of engine throttles to the idle position and activation of deceleration devices (if applicable). The time periods to be used shall be applicable to the airplane configuration and be approved by the procuring activity."

A comparison with previous definitions make it clear that the margins associated with the Naval V_1 and that of the FAA V_1 are not the same. To summarize, in the FAA model, the engine fails one second prior to V_1 , the airplane accelerates to V_1 , continues to accelerate somewhat during the transition period, then is kept at constant speed for two seconds after the transition prior to braking to a stop. In the Navy model, the engine fails at V_1 , the aircraft continues to accelerate with the critical engine out for 3 seconds, then a negotiated period of time passes analogous to the FAA's transition period, prior to the airplane braking to a stop. It is clear that the naval system is quite close to the U.S. Air Force system. Unfortunately the term V_1 is used, identical to the FAA's V_1 , but the definition is different.

50 Feet Obstacle Height

A common point of confusion is the military's 50 foot obstacle height. In both U.S. military systems there is a 50 foot obstacle height mentioned that is sometimes confused with the FAA's 35 foot screen height. Under military rules, fifty feet is guaranteed only when all engines are operating. With the critical engine failed at critical engine failure speed during a critical field length takeoff, military aircraft are only guaranteed to become airborne by the end of the runway. As stated in Boeing's E-6A document D409-12104-1, "Normal takeoff data includes distance from brake release to liftoff and distance from brake release to a 50 foot obstacle height with all engines operating normally."

Conclusion

It should be quite clear that the application of military procedures and techniques to civil aviation is just as wrong as applying civilian procedures and techniques to military aviation. Neither is appropriate and misapplication is potentially disastrous.

(This page intentionally left blank)

U.K. CAA REGULATIONS

Operators who wish to include information on United Kingdom Civil Aviation Authority regulations should contact the manufacturer for specific information relating to the certification of their airplanes.

(This page intentionally left blank)

AUSTRALIAN CAA REGULATIONS

Operators who wish to include information on Australian Civil Aviation Authority regulations should contact the manufacturer for specific information relating to the certification of their airplanes.

(This page intentionally left blank)

FRENCH DGAC RULES

Operators who wish to include information on French Civil Aviation regulations should contact the manufacturer for specific information relating to the certification of their airplanes.

(This page intentionally left blank)

JOINT AIR REGULATIONS (JARS)

Operators who wish to include information on Joint Aviation Authority regulations should contact the manufacturer for specific information relating to the certification of their airplanes.

(This page intentionally left blank)

Reverse Thrust Effectiveness

4-D

This appendix contains information on the effectiveness of thrust reverser systems on modern high bypass engines. Boeing airplanes with various engine combinations are used as specific examples but the trends noted are typical for similar installations on other manufacturers airplanes.

The data in this appendix is provided for training purposes only and should not be used for any other purpose.

(This page intentionally left blank)

Effect of Engine RPM and Airspeed On Reverse Thrust

For engines with fan reversers, net reverse thrust is defined as the reverse thrust developed by the fan reverser system minus the forward thrust generated by the engine core plus ram drag.

A misconception may exist that it is not beneficial to use high power settings for reverse thrust during a rejected takeoff, or after landing. It appears that some flight crew personnel believe that at the higher power settings, the reverse thrust developed by the fan reverser system will be canceled by the forward thrust developed by the engine core. This assumption is not true for thrust reverser systems installed on Boeing airplanes. The net reverse thrust on high by-pass engines is significantly greater at the higher power settings than at idle reverse.

Data shown on figures 1 through 4 are examples of net reverse thrust vs. engine RPM up to the maximum recommended thrust setting and airspeed. Data for other airplanes and engine combination would result in very similar trends. The net reverse thrust (installed), figures 1 through 4, have been corrected to account for the decrease in airplane drag due to reverse thrust operation. The actual reverse thrust (uninstalled) is greater than indicated on the charts. However, the net reverse thrust shown is the effective reverse thrust available for airplane deceleration.

A significant increase in net reverse thrust is achieved as engine RPM is increased up to the maximum recommended power setting. Airspeed also has a very significant effect on net reverse thrust. The airspeed effect is due to ram drag, which is the product of the engine inlet airflow and the airplane forward speed. The combination of high engine RPM and high airspeed can increase the net reverse thrust by a factor of approximately 3 to 4 (depending on the engine model) above the net reverse thrust available at idle power settings. For this reason, when stopping distance is critical, maximum reverse thrust should be applied immediately after landing touchdown or upon initiating a rejected takeoff, concurrently with speedbrakes and maximum braking.

In summary, it is a misconception that high power settings during reverse thrust operation are not beneficial. A significant difference exists between the reverse thrust obtained at idle power settings and at the maximum recommended power settings. Further, reverse thrust should be applied immediately after landing touchdown or upon initiating a rejected takeoff because reverse thrust is significantly more effective at high speeds than at low speeds. Proper utilization of reverse thrust will result in minimum field lengths under adverse runway conditions or increased brake life during normal conditions.

Figure 1

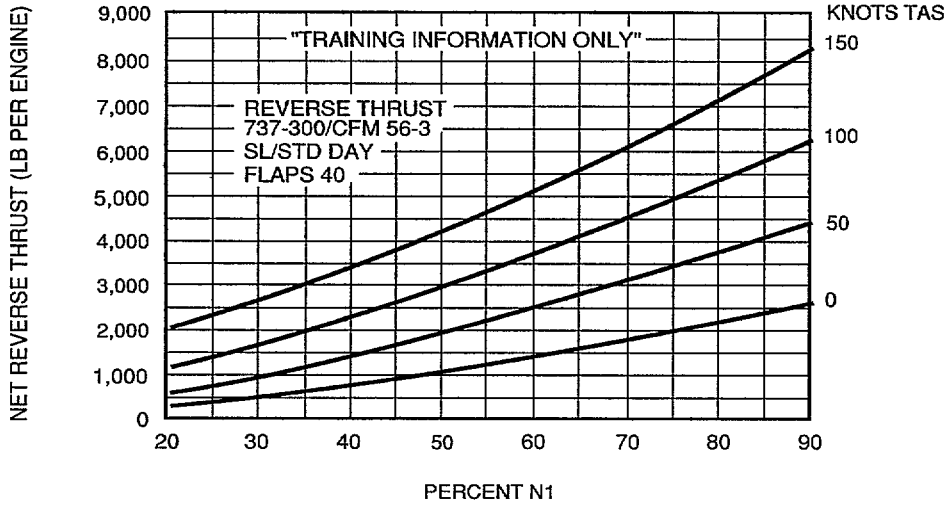
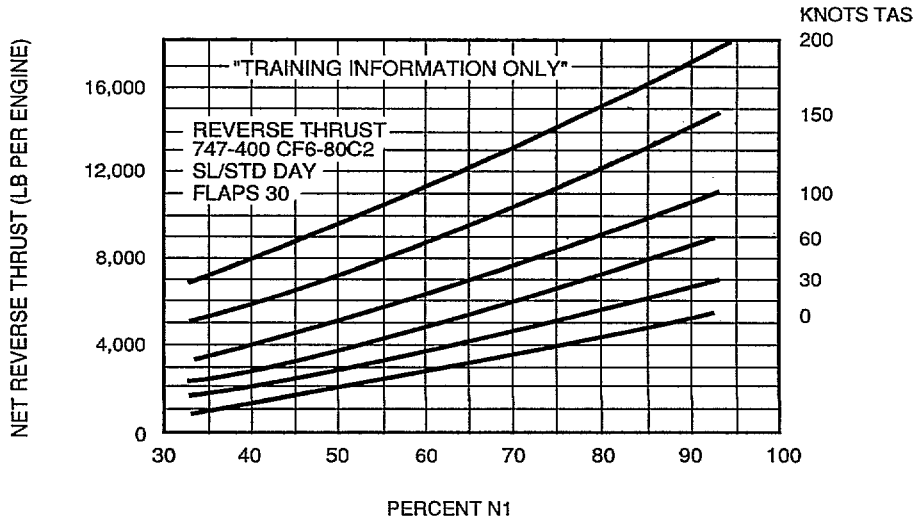

Figure 2



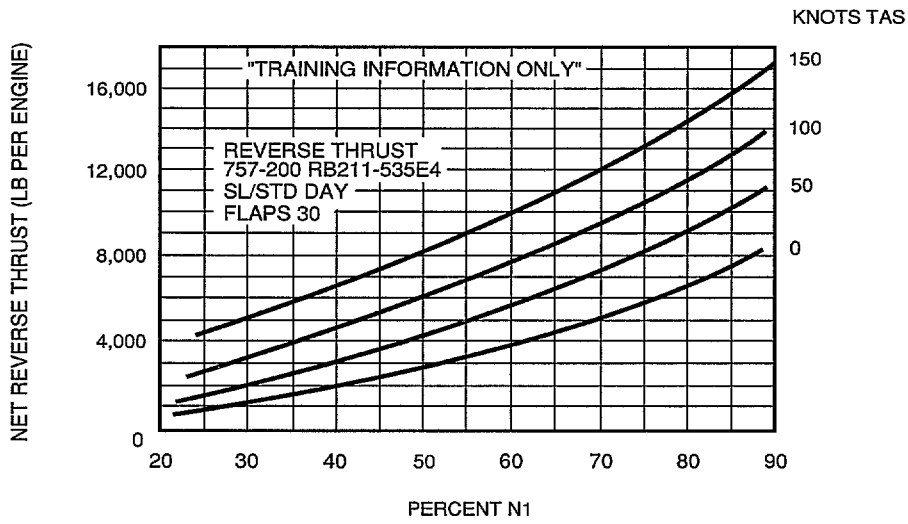

Figure 3

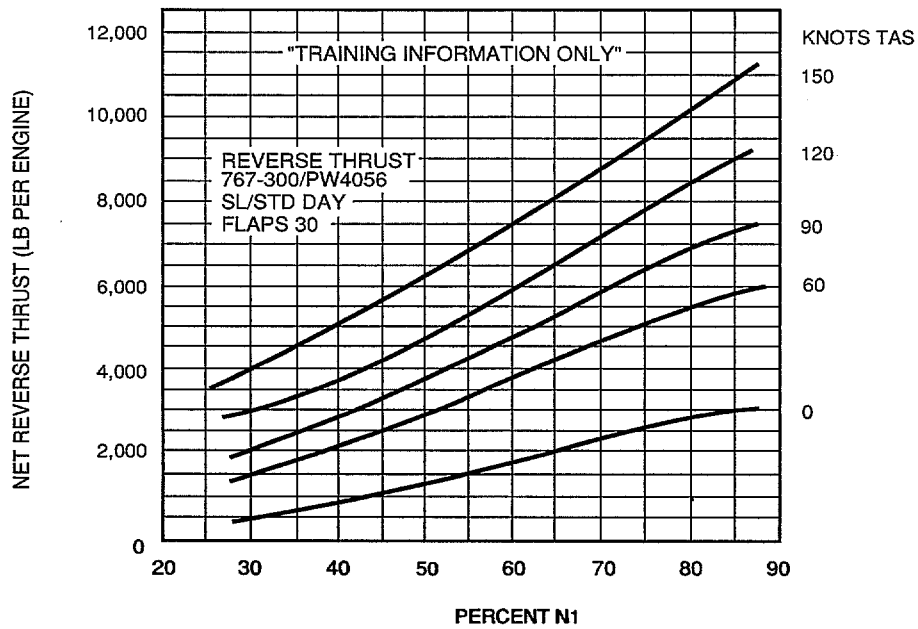

Figure 4

(This page intentionally left blank)

Takeoff Safety Training Aid Human Performance Study

4-E

Introduction

The Boeing Company is presently compiling the information needed to produce a *Takeoff Safety Training Aid*. This training aid, similar to the *Windshear Training Aid*, will be used in the crew training environment. The goal of this training aid is to reduce RTO incidents and accidents. To achieve this goal, the *Takeoff Safety Training Aid's* objective is to improve Go/No Go decision making and crew performance in the execution of necessary RTO's. A simulator study was conducted to obtain a better understanding of the areas in which performance can be improved. Once the Training Aid is developed, the study could be used to confirm that the Aid does provide an improvement in RTO performance.

Test Objectives

The primary purpose of this study was to evaluate pilot decision making and performance under various RTO situations. A B-737 full flight simulator was used to accomplish the study. The specific objectives of this research effort was to examine the following factors involved with RTO decision making and execution:

1. Evaluate decision making involved with making Go/No Go decisions due to the following:
 - A. Engine failure
 - B. Master Caution illumination
 - C. Fire lights and warning bells
 - D. Blown tire
2. Evaluate RTO procedure accomplishment under the following conditions:
 - A. Engine failure
 - B. All manual stop
 - C. Maximum use of automatics stop
 - D. Blown tire
 - E. Exchange of aircraft control

3. Evaluate RTO stopping performance under the following conditions:
 - A. Engine failure
 - B. Manual braking
 - C. Autobraking stop
 - D. Crosswind effects
 - E. Blown tire performance
 - F. Exchange of aircraft control
4. Evaluate the relationship between the pilot's knowledge level about RTO's and his performance in the simulator.

Test Subjects

A total of 48 experienced transport pilots were used in this study. A mix of Boeing pilots and airline captains was necessary to achieve valid human factors results. The pilots were type rated in the B-737 and had current operational experience.

Test Facility and Requirements

The facility used for this test was a B-737 Flight Crew Training simulator at Boeing Customer Training. It is a state-of-the-art simulation facility, and is fully certified for flight crew training by the FAA and CAA. To conduct the test, a qualified B-737 pilot was required to occupy the first officer's seat and a qualified simulator instructor was needed to conduct the test as well as operate the simulator. Simulator engineering assistance was required to retrieve data as well as prepare the simulator for testing. A pre-flight questionnaire, post-flight questionnaire, and method of debriefing was required.

Test Method

The basic design for this study was to compare stopping performance with the Airplane Flight Manual (AFM) predicted distance.

All takeoffs were conducted as a runway limited condition configured as follows:

1. Takeoff weight - 130,000 lb
2. Temperature - 30°C
3. Flaps - 5
4. Field length - 6700 feet

The variables chosen for investigation included:

1. Crosswinds
2. Various malfunctions
3. Forced manual braking RTO
4. Exchange of aircraft control during RTO situations

Exposure to the various RTO's and normal takeoffs was randomized to minimize learning effects and reduce the anticipation normally associated with tests of this type. One and one half hours were required for each pilot to complete the test program. The following is a sample test scenario schedule for a pilot:

Figure 1
RTO Sample Test
Profile

- A. Normal takeoff,
Captain flying
- B. Engine failure at V_1-8 knots,
Captain flying
- C. Engine failure at V_1-8 knots,
F/O flying
- D. Engine failure at V_1+2
knots,
Captain flying
- E. Engine failure at V_1+2
knots,
F/O flying
- F. Fire warning at V_1-5 knots,
Captain flying
- G. Blown tire at V_1-10 knots,
Captain flying
- H. Master Caution light at V_1-10 knots,
Captain flying

The initial prebrief questionnaire was designed to quickly assess the pilot's relative knowledge about RTO's. The remainder of the prebrief was devoted to the understanding of the simulator and test configuration. The pilot then entered the simulator for a quick orientation prior to the test starting. The order in which the pilots received the events was randomized to prevent order bias from influencing the results. The debriefing consisted of a short questionnaire and debriefing to answer any questions the pilot may have had. An informal interview was recorded to obtain pilot comments.

The prebrief questions were:

Write a definition of V_1 .

Can a pilot beat the flight manual performance predicted for rejecting at V_1 ? If so, how?

If your takeoff weight equals the runway limit weight in the airfield analysis, what does that mean to you as a pilot?

Performance Measures

Performance measures were taken in the two areas of decision making and Go/No Go performance. The measures of the stop decision was recorded as the initiation of thrust reduction, brake application, or spoiler deployment. Go/No Go performance was assessed by comparison of the following parameters:

- Speed (knots) versus time (sec)
- Distance to runway end (feet) versus time (sec)
- %N1, L Engine versus time (sec)
- %N1, R Engine versus time (sec)
- Left and Right thrust lever (lever angle) versus time (sec)
- RTO autobrakes (ON/OFF) versus time (sec)
- Left and Right brake force (lb) versus time (sec)

- Speed brake deployed (UP/DOWN) versus time (sec)
- Heading (degrees) versus time (sec)
- Deviation from centerline (feet) versus time (sec)
- Rudder pedal deflection (degrees) versus time (sec)
- Column deflection (degrees) versus time (sec)
- Pitch (degrees) versus time (sec)
- Altitude (feet, RA) versus time (sec)
- Yoke deflection (degrees) versus time (sec)
- Roll angle (degrees) versus time (sec)
- Crosswind velocity (knots) versus time (sec)

Data Reduction and Analysis

The data is classified into two general categories: objective performance measurements and subjective data from questionnaires and debriefing.

The results from this analysis provided information to determine if the following were true:

1. There is no effect on RTO performance with crosswinds.
2. There is no effect on RTO performance with the exchange of aircraft control.
3. There is no effect on RTO performance when using full automatic capability as compared to manual performance.
4. Non engine-related problems have no effect on RTO decision time or performance.

Simulator Test Results

Phase 1 of the simulator tests began April 17, 1991 and was completed on May 3, 1991. During this time period, 24 Boeing 737 Training Captains were tested. These pilots averaged 3.5 years with Boeing. After participating as the first captain, one pilot became the first officer for the remaining captains. He was a training captain with considerable line experience and was able to closely emulate the characteristics of a good line first officer.

After evaluating the data and confirming the test process and data reduction techniques, a meeting was held in Seattle with the airlines and agencies participating in the development of the Training Aid. The test results were presented and volunteers were solicited to participate in Phase 2 of the study.

Phase 2 began on July 16, 1991 and was completed on September 12, 1991. Twenty-four 737 Line Captains (no Check Airmen, no simulator instructors, no Training Captains) were evaluated from five airlines. There were no more than eight pilots per airline to keep from biasing the results in the favor of one type of training or one airline's policies.

Two Boeing Training Captains were used as first officers for these captains. The original first officer was used again along with another training captain of similar background and experience. This second first officer had also participated in Phase 1 of the study.

As illustrated in Figure 2, the two pilot groups were surprisingly similar in background and experience.

	Boeing	Airline
Total time, hrs	11,546	12,308
737 time, hrs	1,918	3,748
Airline years	11	16
Military years	9	6
number rejects	3.3	4.8

*Figure 2
Comparison
Of Boeing
Subjects
With Airline
Subjects*

Test Results - Go/No Go Decision Making

Although results varied considerably between airlines, when the airline pilots were taken as one group and Boeing as another, the basic decisions made when presented the study scenario were remarkable similar.

As can be seen in Figure 3, the number of rejects per event varied by 1 in all cases except engine fire. As a result of this similarity, later findings will be presented for the 48 pilots as one group.

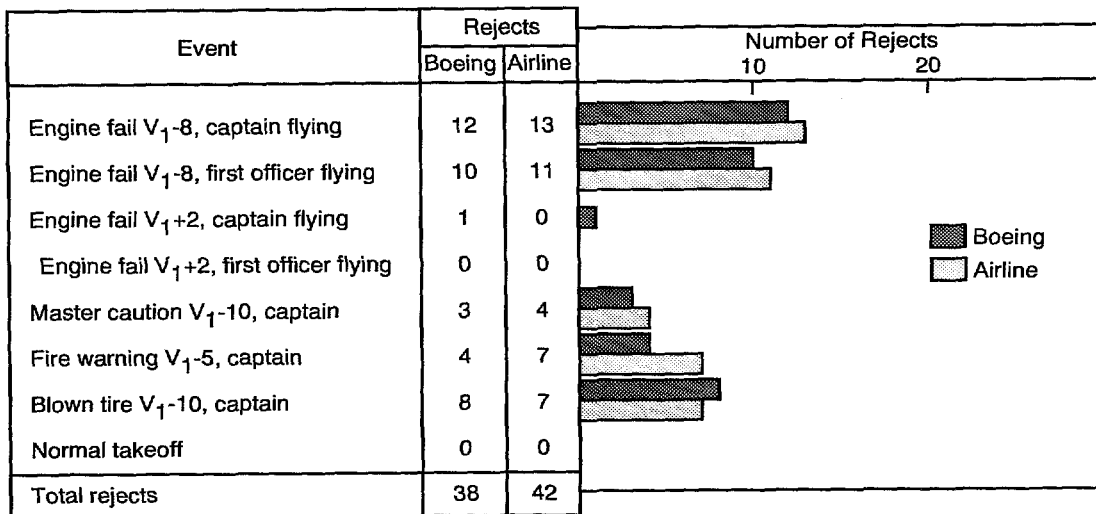
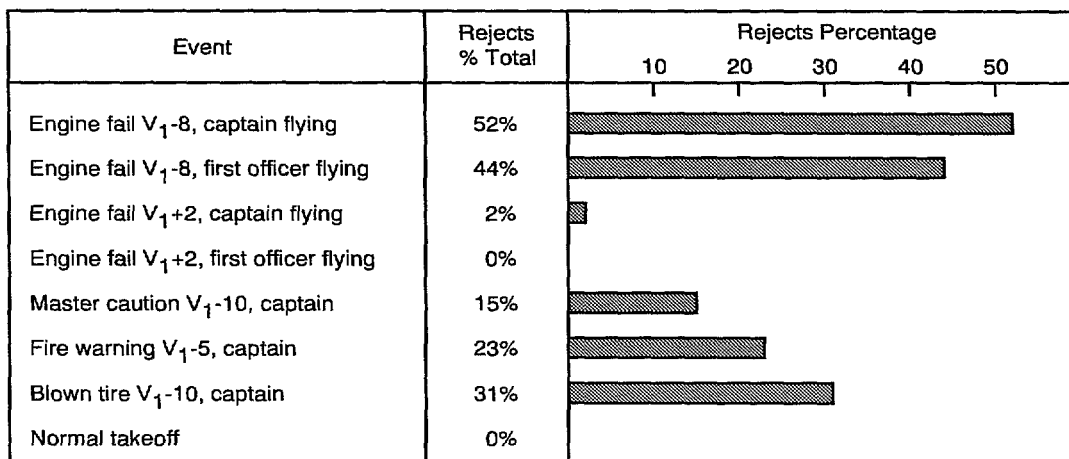

Figure 3
"Go/No Go"
Decision

As seen in Figure 4, pilots did not reject their takeoffs as often as was anticipated in the "classical" cases that are normally trained, namely engine failures and fires. Another surprise occurred in the "nonclassical" cases. Almost one-third of the pilots rejected for the blown tire although the only indication was a vibration. There were seven rejects for a Mas-

ter Caution light which in this case came on due to a hydraulic pump overheat 10 knots below V_1 . Boeing, along with most airlines, specifies that "Once thrust is set and takeoff roll has been established, rejecting a takeoff solely for illumination of the amber MASTER CAUTION light is not recommended."

Figure 4
"Go/No Go"
Decision
Making



Test Results - Procedure Accomplishment

When a captain did reject a takeoff, his procedure was evaluated against his published company policy. All Boeing pilots have a procedure which says to "Simultaneously close the thrust levers (disengage the autothrottle, if required) and apply maximum brakes. If RTO autobrakes are selected, monitor system performance and apply manual wheel brakes if the AUTO BRAKE DISARM light illuminates or deceleration is not adequate. Rapidly raise the speedbrakes and apply maximum reverse thrust consistent with the conditions." Some

airlines represented also had this as their procedure, while others had a procedure to raise the speedbrakes through the use of the reverse thrust levers and monitor the speedbrake handle for proper operation. As can be seen in Figure 5, the number of incorrect procedures used was rather high. The incorrect procedure used in each case was selecting reverse thrust prior to raising the speedbrake. This was only applied to those airlines/Boeing which have that procedure in their manuals. For the Boeing subjects, it is immediately apparent that the rate of incorrect procedures is much higher for the "nonclassical" cases than for the "classical".

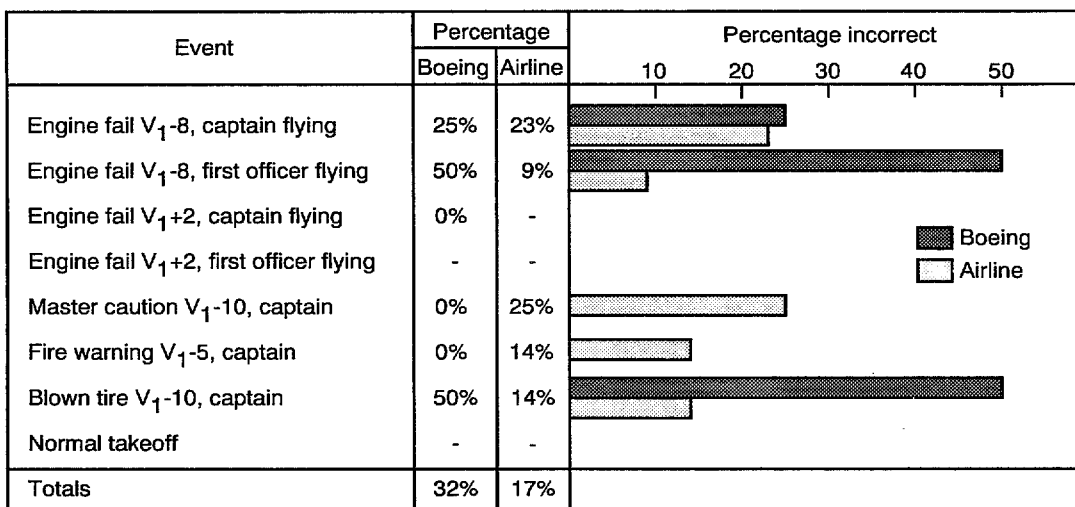
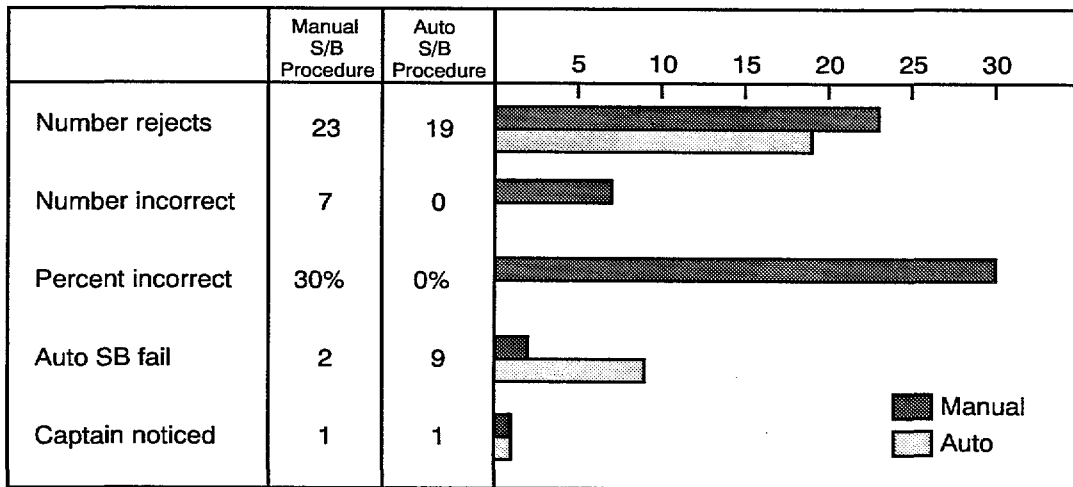

Figure 5
Procedural
Accomplishment

It would seem that the Boeing Pilots have a greater propensity to incorrectly accomplish the procedure than airline pilots, however, from Figure 6, it is apparent that airlines using manual speedbrake have about the same error rate as the Boeing pilots. Pilots using auto speedbrake did the procedural steps correctly every time.

During the course of the study, a new variable was unintentionally introduced. Due to a simulator malfunction, the auto speedbrake failed for a period of time resulting in an opportunity to observe the ability of pilots using that device to monitor its deployment. It is apparent that it is not very well monitored. The first officer would only raise the speedbrake if he was briefed by the captain to do so. Only one captain did, so in those 2 out of 9 cases, the first officer raised the speedbrake.

*Figure 6
Procedure Accom-
plishment For
Airline Pilots Only*



Test Results - Stopping Performance

Stopping performance as measured by runway remaining was averaged for all rejects for each situation presented. Pilots were able to stop the airplane with the greatest margin in the few cases when the Master Caution illuminated ten knots prior to V_1 . In this case the pilot had two engine reverse thrust and the malfunction

occurred with the greatest margin before V_1 . The worst case was the reject initiated after V_1 , followed closely by the rejects for the blown tire. The simulator eliminates braking force from the wheel with the failed tire reducing the total brake retarding force to 75% of what it normally would be. As a result, only 3 of 15 pilots were able to stop the aircraft prior to the end of the runway, and those, just barely.

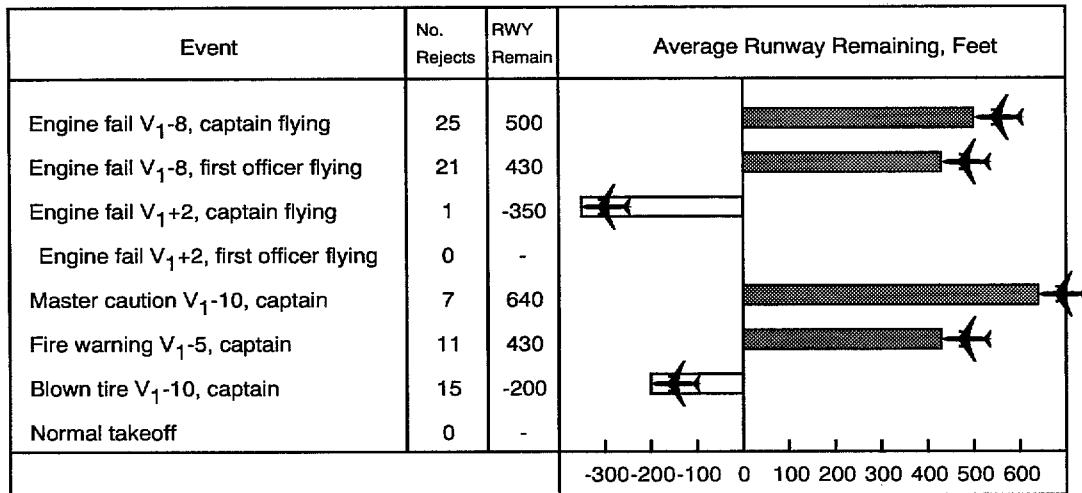

Figure 7
Stopping
Performance

Test Results - Responses to Questions versus Simulator Performance

The data taken did not show any correlation between performance in the simulator and response to the questions asked.

Test Results - Training versus RTO Performance

Training and company policy appear to play a significant role in the decisions pilots make. From Figure 8, it can be seen that as expected, Boeing contributed 50% of the pilots to the study and accomplished 47% of the rejected takeoffs. However, Airline 1 and Airline 2 contributed the same number of pilots yet Airline 1 pilots rejected almost twice as many times as did Airline 2 pilots.

Figure 8 Participation Versus RTO'S Accomplished

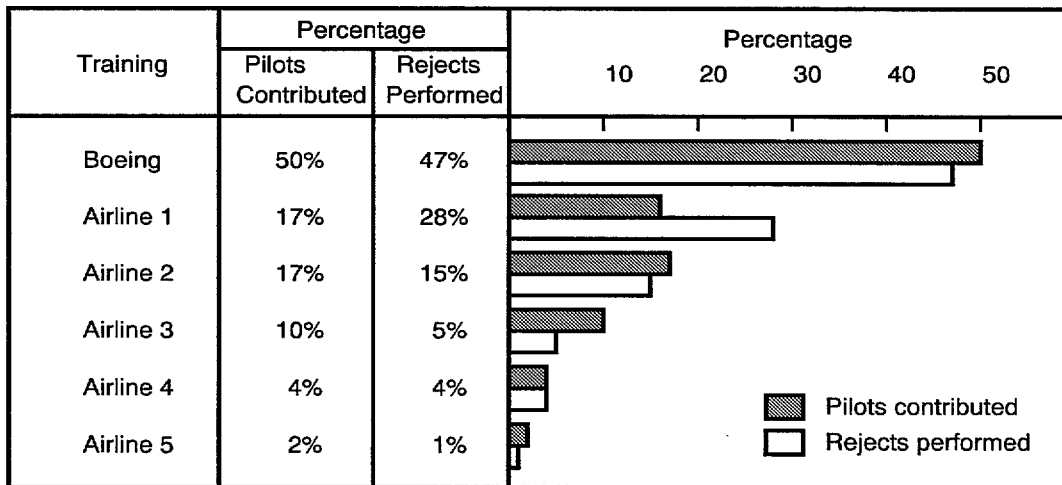

Data Reduction and Analysis

Once all the data was received it was used to answer the questions posed in the Test Plan.

1. There is no effect on RTO performance with crosswinds.

As can be seen in Figure 9, crosswinds had a minor effect on stopping margins although the expected result of an increase in distance with a crosswind was clearly there. The increase results from pilots steering with differential braking and thus reducing the total braking force applied.

Calm winds	-	390 feet remaining
15 knot crosswinds	-	330 feet remaining

*Figure 9
Crosswind Effect
On Stopping
Margins*

2. There is no effect on RTO performance with the exchange of aircraft control.

As can be seen in Figure 10, exchange of aircraft control did have an effect on stopping performance. The stopping margins achieved when the captain was performing the takeoff exceeded those of all first officer takeoffs. There were variations regarding the ability of the copilot to make the reject decision and what technique would be used if the reject decision was made. When the first officer actually

performed the reject, the stopping distance margins were smaller yet. During first officer takeoffs with the captain performing the reject, there were few crew coordination problems, however in the situation when the first officer performed the reject, there often were crew coordination difficulties. There is an inherent delay when the captain is required to make the reject decision and verbalize it, then the first officer reacts and performs the procedure. There is also a physical difficulty in the first officer raising the speedbrake.

Engine fail V₁-8

Figure 10

- Captain flying (25) - 500 feet remaining
- F/O flying (21) - 430 feet remaining
 - F/O rejects (7) - 320 feet remaining

Note: All airline rejects done by the captain

3. There is no effect on RTO performance when using full automatic capability as compared to manual performance.

The use of autobrakes significantly increased stopping margins. The most common stopping technique was to apply manual wheel brakes

as the last step in the RTO procedure. Since autobrakes come on as soon as the thrust levers come to idle, autobrakes gave a 1-2 second earlier brake application. RTO brakes also applied more consistent braking force. The negative side of autobrakes is that they can be inadvertently disengaged resulting in no braking force being applied for a few seconds until the crew notices it.

- RTO autobrakes increased stopping margin

- Autobrakes armed: 450 feet remaining (36 cases)
- Manual braking: 270 feet remaining (40 cases)
- Autobrake on more than 4 seconds: 610 feet remaining (4 cases)

*Figure 11
Stopping Margins
with Autobrakes
ARMED versus OFF*

- 4. Non engine-related problems have no effect on RTO decision time or performance.

Decision Time

As suspected, decision times increased for events that were more difficult to recognize

and that are not as well practiced. The shortest time from event to first action occurred for the engine fire warning given at 5 knots prior to V₁. This time was taken as the reference to compare the other times. It should be noted that "Go" decision time was not measured since there is no clear activity other than a continued takeoff to indicate the decision.

*Figure 12
Type Of Event
Vs Decision
Time**

Fire warning V ₁ -5, captain	Reference time
Engine fail V ₁ -8, captain	Reference time + .2 seconds
Master caution V ₁ -10, captain	Reference time + .4 seconds
Engine fail V ₁ -8, first officer	Reference time + .6 seconds
Blown tire V ₁ -10, captain	Reference time + .6 seconds

*Time between event and first stopping action

Procedural Performance

Procedural accomplishment was very similar to the decision time statistics. Again, it appears that the less familiar or more difficult to discern the event is, the more likely the pilot is to do the manual speedbrakes procedure incorrectly.

- Boeing and airlines whose procedure is manual speed brake, 32% of the RTO's were done using auto speedbrake
 - 42% for blown tire, captain flying
 - 35% for the engine fail, V₁-8, first officer flying
 - 30% for the engine fail V₁-8, captain flying
 - 25% for the master caution, captain flying
 - 14% for the fire warning V₁-5, captain flying

*Figure 13
Procedure
Accomplishment
Boeing/Airlines
Using Manual
Speedbrake*

LESSONS LEARNED

Certain observations can be made from the data taken. These are divided into the areas of decision making, procedure accomplishment, stopping performance, and knowledge.

Decision Making

The pilots tested were more "Go" oriented than anticipated. From the briefings it was discovered that many of the pilots used an informal "pad" of 5-20 knots less than V_1 as a speed beyond which they will not begin a reject when in a runway limit situation.

This "Go" orientation appears to be stronger when the first officer is making the takeoff. It was even more apparent when the first officer is responsible for performing the reject procedure.

The vibration associated with a blown tire appears to induce pilots to reject with no other malfunction indications.

In spite of clear recommendations to the contrary, a few pilots rejected for illumination of the Master Caution light in the high speed regime.

Procedure Accomplishment

For Boeing and Airlines using manual speed-brake:

- 32% of the RTO's were done using incorrect procedures
- 42% for BLOWN TIRE RTO'S, CAPT FLYING
- 35% for ENG FAIL, V_1 -8 RTO'S, F/O FLYING
- 30% for ENG FAIL V_1 -8 RTO'S, CAPT FLYING
- 25% for MASTER CAUTION RTO'S, CAPT FLYING
- 14% for FIRE WARNING V_1 -5 RTO'S, CAPT FLYING

Stopping Performance

The use of improper procedure and techniques increases stopping distance.

Non-optimal techniques included:

- Improper foot position
- Modulating brake pressure (pumping brakes)
- Disconnecting RTO Autobrakes and delayed manual application

Crew Coordination Difficulties

Crew coordination when first officer flying:

Worst Case

Captain calling the reject and first officer doing the RTO

Best Case

Captain controlling the thrust levers and doing the RTO

Manual versus RTO Autobraking

Most distance remaining:

RTO Autobrakes left on for entire stop

Few pilots matched or exceeded the performance of the autobrakes.

Most common technique:

Autobrakes initiate the braking and the pilot completes the stop

Knowledge versus Performance

The data taken does not show a correlation between performance in the simulator and responses to the questions asked. However, the questions asked did reveal some general misconceptions about RTO's:

- 50% said it was not possible to stop shorter than the AFM predicted distance
- few stated an awareness of the altitude over the end of the runway when continuing a takeoff after an engine failure
- most gave an incomplete definition of V_1

Takeoff Continued

Although it was not a specific study item, it is very significant that of the 70 takeoffs continued by the captains tested with an engine failure, there was not a single crash.

Opportunities for Improvement

The results of the study bring up several areas of operation that can be improved:

Decision Making

Emphasize an accurate meaning of V_1

Assure an accurate understanding of Go/No Go margins

Pilots must understand the effects of the reduction in screen height resulting from a continued takeoff with an engine failure prior to V_1

The impact of using reverse thrust and quick reaction time to enhance stopping performance requires emphasis

The blown tire problem needs significant emphasis in training

Academic training emphasizing the adverse impact on stopping performance needs to be included

Simulator training to demonstrate the "feel" of the blown tire and the merits of continuing the takeoff should be done

Procedure Accomplishment

Proper (accurate) accomplishment of the RTO procedure needs additional emphasis

Improved crew communication and coordination

Inservice procedure review

or

Change the procedure to incorporate the use of auto speedbrake so that it is more like the well-practiced landing procedure.

However, pilots relying on auto speed brake for conducting the RTO must devise a reliable method of confirming that the speed brake has raised.

A recommendation to standardize the RTO procedure to have the captain control the thrust levers once takeoff thrust is set and perform the rejected appears to be appropriate.

Stopping Performance

Include training/information about foot position for takeoff and landing.

Greater emphasis should be given to the value of RTO autobrakes. Demonstration of autobrake rejected takeoffs may add value, however, manual braking techniques should be emphasized in training.

Experience, Knowledge, and Training

During simulator training, realistic rejected takeoffs should be presented in field length limit situations to confirm proper braking techniques and crew coordination.

The training given should reflect known causes of RTO accidents and incidents.

(This page intentionally left blank)

Airplane Flight Manual Transition Time Details

4-F

The data in this appendix is provided as a reference for the instructor. The individual diagrams show the relationship between the average time required to reconfigure the airplane for an RTO in the certification flight tests and the expanded times used in the computation of certified takeoff performance in the AFM.

The AFM transition time data supplied to operators by the various airframe manufacturers should be retained in this appendix as follows:

Table of Contents

<u>Airplane Manufacturer</u>	<u>Page</u>
Airbus Industries Airplanes	4-F.ABI.1
Boeing Airplanes	4-F.TBC.1
McDonnell Douglas Airplanes	4-F.MCD.1
Other Manufacturers Airplanes	4-F.OTH.1

The data contained in this appendix is provided for training purposes only and should not be used for any other purpose. Each manufacturer assumes responsibility only for the data which applies to their specific airplane models. Questions regarding any information presented in this appendix should be addressed to the responsible manufacturer

(This page intentionally left blank)

Brake Pedal Force Data

4-G

The data in this appendix is provided as a reference for the instructor. The individual charts show the brake pedal force required to apply full brake system pressure, to set the parking brake, and to disarm the RTO autobrake function, if applicable.

The brake pedal force data supplied to operators by the various airframe manufacturers should be retained in this appendix as follows:

Table of Contents

<u>Airplane Manufacturer</u>	<u>Page</u>
Airbus Industries Airplanes	4-G.ABL.1
Boeing Airplanes	4-G.TBC.1
McDonnell Douglas Airplanes	4-G.MCD.1
Other Manufacturers Airplanes	4-G.OTH.1

The data contained in this appendix is provided for training purposes only and should not be used for any other purpose. Each manufacturer assumes responsibility only for the data which applies to their specific airplane models. Questions regarding any information presented in this appendix should be addressed to the responsible manufacturer.

(This page intentionally left blank)

Reduced Thrust and Reduced V_1 Examples

4-H

The data in this appendix is provided as a reference for the instructor. The first page for each airplane model shows the inherent margins associated with the use of the Assumed Temperature Method (ATM) of reduced thrust, as described in Section 4.3.5.7 of the main document.

The second page for each airplane model contains an example of using ATM in combination with a reduced V_1 policy as described in Sections 4.3.4.2 and 4.3.6.8 of the main document.

These examples are generally typical of the margins for the derivatives of a given airplane model also, so not all airplane/engine combinations are included.

The reduced thrust and reduced V_1 data supplied to operators by the various airframe manufacturers should be retained in this appendix as follows:

Table of Contents

Airplane Manufacturer	Page
Airbus Industries Airplanes	4-H.ABI.1
Boeing Airplanes	4-H.TBC.1
McDonnell Douglas Airplanes	4-H.MCD.1
Other Manufacturers Airplanes	4-H.OTH.1

The data contained in this appendix is provided for training purposes only and should not be used for any other purpose. Each manufacturer assumes responsibility only for the data which applies to their specific airplane models. Questions regarding any information presented in this appendix should be addressed to the responsible manufacturer.

(This page intentionally left blank)

Lineup Distance Charts

4-I

The data in this appendix is provided as a reference for the instructor. The data contained in this appendix is based on the manufacturer's data for minimum turn radii consistent with their recommended turn procedures. Operators can use the data in this appendix to develop lineup corrections appropriate to any runway turn geometry. However, the use of data in this appendix does not supersede any requirements that may be already be in place for specific regulatory agencies. If further assistance is required, the operator should contact the appropriate manufacturer and regulatory agency to assure compliance with all applicable regulations.

The lineup distance data supplied to operators by the various airframe manufacturers should be retained in this appendix as follows:

Table of Contents

Airplane Manufacturer	Page
Airbus Industries Airplanes	4-I.ABI.1
Boeing Airplanes	4-I.TBC.1
McDonnell-Douglas Airplanes	4-I.MCD.1
Other Manufacturers Airplanes	4-I.OTH.1

The data contained in this appendix is provided for training purposes only and should not be used for any other purpose. Each manufacturer assumes responsibility only for the data which applies to their specific airplane models. Questions regarding any information presented in this appendix should be addressed to the responsible manufacturer.

(This page intentionally left blank)

The Effect of Procedural Variations on Stopping Distance

4-J

The data in this appendix is provided as a reference for the instructor. The individual diagrams show the approximate effects of various configuration items and procedural variations on the rejected takeoff stopping performance of the airplane.

The procedure variation data supplied to operators by the various airframe manufacturers should be retained in this appendix as follows:

Table of Contents

<u>Airplane Manufacturer</u>	<u>Page</u>
Airbus Industries Airplanes	4-J.ABI.1
Boeing Airplanes	4-J.TBC.1
McDonnell Douglas Airplanes	4-J.MCD.1
Other Manufacturers Airplanes	4-J.OTH.1

The data contained in this appendix is provided for training purposes only and should not be used for any other purpose. Each manufacturer assumes responsibility only for the data which applies to their specific airplane models. Questions regarding any information presented in this appendix should be addressed to the responsible manufacturer.

(This page intentionally left blank)

A

Academic Training Program 3.2
 objectives 3.2
 program modules 3.2
 syllabus 3.2
Accidents 2.4-2.5, 4.5-4.6
 List 1959-1990 Appendix 4-B
 statistics 2.1-2.7, 4.2A.8
Airplane configuration 2.22, 4-25
Answers, examination 3B.18
Anti-skid 2.20, 2.25, 2.30, 4.23, 4.28, 4.34
Anti-skid inoperative braking 2.39, 4.46
Atmospheric conditions 2.21, 2.22, 4.24
Autobrakes 2.39, 4.46
Autothrottle 2.37, 4.44

B

Balanced Field
 defined 2.11, 4.12
Brakes 2.24-2.31, 4.274.35
 automatic 2.39, 4.46
 carbon 2.29, 2.30, 4.33, 4.34
 energy 2.27, 2.31, 4.35
 fires 2.31, 4.35
 manual 2.38, 4.45
 pedal force data Appendix 4-G
 reverse thrust effects 2.32, 4.36
 residual brake energy 2.27, 4.31
 RTO autobrakes 2.39, 4.46
 steel 2.29, 2.30, 4.33, 4.34
 worn 2.27, 4.30
Braking
 speedbrake effect 2.27-2.29, 4.31-4.33
 while hydroplaning 2.20, 4.23
Braking Techniques
 accident factor 2.7, 4.8
 antiskid inoperative 2.39, 4.46
 autobrakes 2.39, 4.46
 flight manual 2.9, 2.12-2.14, 4.14, 4.15
 manual 2.38
Briefing
 instructor pilot Appendix 3-A
 takeoff 2.41, 4.51
 Takeoff Safety Appendix 3-C

C

Callouts 2.40, 2.42, 4.50, 4.52
Carbon Brakes 2.29-2.31, 4.33-4.35
Configuration Deviation List (CDL) 2.22, 2.23, 4.25, 4.26
Configuration 2.22
Crew Members 2.41, 2.42, 4.51, 4.52
Crew Preparedness 2.40, 4.50
Crew Resource Management (CRM) 2.41, 2.42, 4.51, 4.52
 briefing 2.41, 4.51
 callouts 2.42, 4.52
 summary 2.42, 4.52
 use of crew members 2.42, 4.52
 with the RTO 2.41, 4.51

D

Decisions 2.1-2.7, 2.41, 4.2A.8, 4.51
Definitions 3-A.1 - 3-A.3
Documentation Overview 1.2

E

Effect of Procedural Variations on Stopping Distance Appendix 4-j Engines
 accident factor 2.6, 4.7
 bleed air 2.22, 4.25
Examination Questions Appendix 3-B
Exercises
 simulator 3.3-3.14, Appendix 3-D

F

Factors that affect takeoff and RTO performance 2.19-2.35
Flaps 2.22, 4.25
 selection 2.36, 4.43

G

"Go" margins 2.16-2.19, 2.23, 2.34-2.37, 2.39, 4.17, 4.18-4.21, 4.25, 4.38-4.44
Grooved Runways 2.20, 2.21, 3.15, 4.23, 4.24

H

High brake energy RTO's 2.31, 4.35
Human Performance Study Appendix 4-E
Hydroplaning 2.20, 4.23

I

Instructor Examination Guide 3-B.9
Instructor Pilot Syllabus Briefing Supplement Appendix 3-A
Introduction 1.1, 2.1, 3.1, 4.1

L

Landing gear retraction 2.25, 4.28
Lessons Learned 2.7,4.8
Lineup Distance 2.37, 4.38, 4.39, 4.44
 charts Appendix 4-1

M

Manual Braking Techniques 2.38, 2.39, 4.45
Margins
 "Go" 2.16-2.19, 2.23, 2.34-2.37, 2.39, 4.17, 4.18-4.21, 4.25, 4.38-4.44
 "Stop" 2.15-2.19, 2.23, 2.34-2.36, 4.16, 4.18-4.21, 4.25, 4.38-4.44
Minimum Equipment List (MEL) 2.22, 2.23, 4.25, 4.26
Missing or inoperative equipment 2.22, 2.23, 4.25, 4.26

N

NTSB 2.1,2.27,4.1,4.30
 Special Investigation Report SIR-90/02 Appendix 4-A

O

Objectives 1.2, 2.1, 3.2, 3.3, 4.1
Overview for Management 1.i-1.4
 conclusion 1.3
 documentation overview 1.2
 general goal and objectives 1.2
 industry consensus 1.3
 introduction 1.1
 resource utilization 1.3
Other Takeoff Rules Appendix 4-C

P

Pilot Guide to Takeoff Safety Questions Appendix 3-B
Procedural Variations 2.28, 4.32
 effect on stopping distance Appendix 4-J

Q

Questions Appendix 3-B

R

Reduced Thrust 2.34, 4.40, Appendix 4-H
Reduced V_1 Techniques 4.47, Appendix 4-H
Residual brake energy 2.27, 4.31
Reverse Thrust effectiveness 2.32, 4.36, Appendix 4-D
RTO autobrakes 2.39, 4.46
Rules Appendix 4-C
Runway
 excess 2.19, 4.20
 grooved 2.20, 2.21, 3.15, 4.23, 4.24
 lineup 2.37, 4.44
 parameters 2.32, 2.33, 4.37
Runway Surface Condition 2.5, 2.19, 2.35, 4.6, 4.22, 4.42

S

Safety Margins 2.35, 4.42
Script, Video Appendix 3-E
Setting Takeoff Thrust 2.37, 4.44
Simulator
 exercises 3.6-3.14, Appendix 3-D
 fidelity checks 3.15
 grooved runways 3.15
 Implementation Guide 3.15
 tuning for accomplishment of objectives 3.15
Simulator Study Appendix 4-E
Simulator Training Program 3.3-3.9
 objectives 3.3
 pilot simulator briefing 3.6
 training syllabus 3.4
 syllabus 3.4
Speedbrake
 effect on braking 2.27-2.29, 4.31-4.33
Statistics 2.1-2.3, 2.5-2.6, 4.2-4.7
Steel Brakes 2.29-2.31, 4.33-4.35
"Stop" margins 2.15-2.19, 2.23, 2.34-2.36, 4.16, 4.18-4.21, 4.25, 4.38-4.44
Stopping Distance
 effect of procedural variations Appendix 4-J
 effect of runway surface condition 2.19, 4.22
 effect of speedbrake 2.28, 4.32
Student Examination 3-B.1
Summary 2.42, 4.53
Summary of Answers 3-B.18

T

Takeoff

- atmospheric conditions 2.21, 4.24
- briefing 2.31, 2.41, 4.35, 4.51
- calculations 2.18, 4.19
- callouts 2.40, 2.42, 4.50, 4.52
- configuration 2.22, 4.25
- data 2.35, 4.42
- factors 2.19-2.35, 4.21-4.42
- FAR Definitions 3-A.1 - 3-A.3
- field length 2.9, 4.10
- flap selection 2.36, 4.43
- lineup distance 2.37, 4.38, 4.39, 4.44, Appendix 4-I
- reduced thrust 2.34, 4.40, Appendix 4-H
- rolling 2.37, 4.44
- rules 2.8-2.17
- setting thrust 2.37, 4.44

Takeoff Safety Briefing Appendix 3-C

Takeoff Safety Video Script Appendix 3-E

Taxi Technique 2.24, 4.27

Thrust

- loss 2.6, 4.7
- reduced 2.34, 4.40, Appendix 4-H
- reverse 2.32, 4.36, Appendix 4-D
- setting 2.37, 4.44

Tires 2.24-2.26, 2.31, 4.27-4.29, 4.35

Training Programs See Academic Training Program, Simulator Training Program

Transitions 2.12-2.14, 4.13-4.15, Appendix 4-F

V V_I

- callout 2.40, 2.42, 4.50, 4.52
- defined 2.10, 3-A.1, 4.11
- reduced 4.47

V_{LOF} 3-A.2

V_{mca} 2.34

V_{mcg} 2.34

V_R 3-A.2

V_2 3-A.2

Video Script Appendix 3-E

W

Wheels 2.24-2.27, 4.27-4.32

(This page intentionally left blank)