

ATR 42-600



ATR: THE N°1 CHOICE IN THE REGIONAL MARKET

With the 600 Series, ATR has reinforced its leadership position in the turboprop market. The ATR 42-600 is the only 50-seater aircraft in production. Its size makes it a natural choice for both thin and niche markets. Thanks to its smaller capacity and low trip costs, it is perfectly suited to developing new routes. Its high commonality with the ATR 72-600 makes the ATR-600 Series the ideal regional tool giving operators the flexibility to adapt seat capacity to traffic demand.

ADVANCED TECHNOLOGY

The ATR-600 features a state-of-the-art glass cockpit incorporating the latest innovations in avionics technology. This glass cockpit brings further reduction in flight crew workload, enhances situational awareness while providing better reliability, maintenance cost savings and weight reduction.

SUPERIOR COMFORT

The ATR-600 Series has the widest cabin in the turboprop market. More comfort and space are offered to passengers with new lightweight and slim seats. In addition, the ATR-600 Series is fitted with wider, reshaped overhead bins providing 30% more roller bags stowage capability compared to ATR-500 Series.

OUTSTANDING PERFORMANCE

The ATR 42 is designed to have excellent performance, especially on unpaved or narrow runways, as well as at challenging airports with short runways or close-in obstacles, thanks to its steep slope approach capability.

In addition, the ATR 42-600 includes the "reserve take-off torque" option which allows reduced take-off distances, increased payload and optimised revenue from very short runways.



atrbroadcast



atraircraft



atr-aircraft.com



atraircraft



atr

ATR
PROPELLING THE NEXT CONNECTION

ATR 42-600

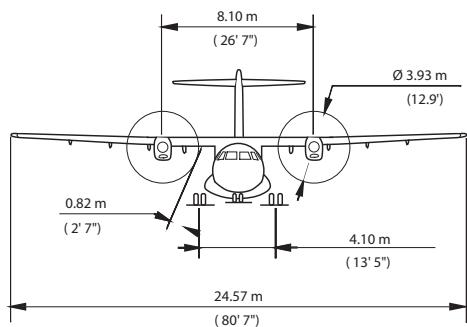
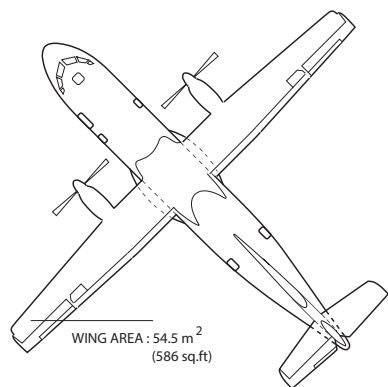
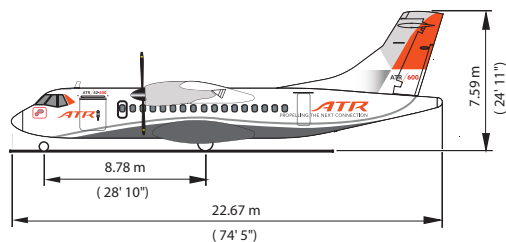

ENGINES

Pratt & Whitney Canada	PW127M
Take-off power	2,160 SHP
Take-off power - One engine	2,400 SHP
Max continuous	2,400 SHP
Max climb	2,160 SHP
Max cruise	2,132 SHP

PROPELLERS

Hamilton Standard: 568F
Blades: 6; diameter: 3.93 m - 12.9 ft

WEIGHTS

Max take-off weight (basic)	18,600 kg - 41,005 lb
Max landing weight (basic)	18,300 kg - 40,344 lb
Max zero fuel weight (basic)	16,700 kg - 36,817 lb
Operational empty weight (Tech. Spec.)	11,550 kg - 25,463 lb
(Typical in-service)	11,700 kg - 25,794 lb
Max payload (at typical in-service OEW)	5,300 kg - 11,684 lb
Max fuel load	4,500 kg - 9,921 lb

* Optional MZFW@17,000 Kg available on demand.

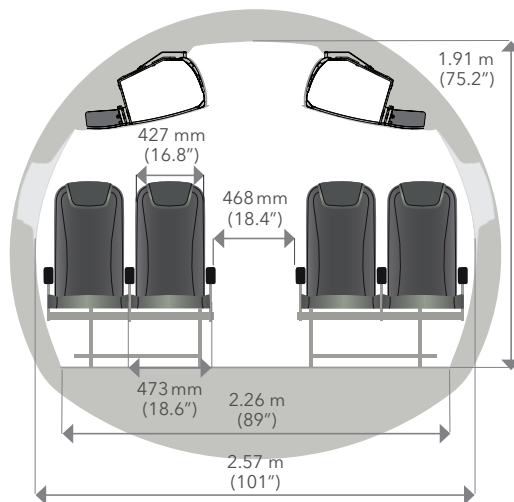

STANDARD CONFIGURATION

48 seats at 30" pitch

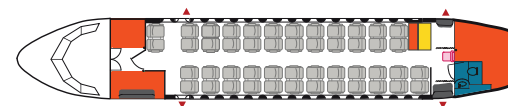

■ Attendant seat ■ Galley ■ Toilet ■ Baggage ▲ Emergency Exits

AIRFIELD PERFORMANCE

TAKE-OFF DISTANCE:	
Basic (MTOW - ISA - SL)	1,165 m - 3,822 ft
At TOW for 300 Nm (Max pax - ISA - SL)	1,025 m - 3,363 ft
At TOW for 300 Nm (Max pax - ISA+10 - 3,000 ft)	1,215 m - 3,986 ft
TAKE-OFF SPEED (V2 min @ MTOW)	112 KCAS
LANDING FIELD LENGTH (JAR25)	
Basic (MLW - SL)	1,126 m - 3,694 ft
At LW (Max pax + reserves - SL)	1,055 m - 3,461 ft
REFERENCE SPEED AT LANDING	104 KIAS

EN-ROUTE PERFORMANCE

Optimum climb speed	160 KCAS
Rate of climb (MTOW - ISA - SL)	1,851 ft/min
Max Cruise speed	300 KTAS - 556 km/h
(95% MTOW - ISA - Optimum FL)	
Fuel flow at cruise speed	811 kg/h - 1,788 lb/h
Range with Max pax (48 seats)	716 Nm
200 Nm Block fuel	565 kg - 1,246 lb
CO ₂ emission	1,780 kg - 3,925 lb
Block Time	54.1 min
300 Nm Block fuel	783 kg - 1,727 lb
CO ₂ emission	2,467 kg - 5,439 lb
Block Time	75.0 min

NB: en-route performance computed assuming typical in-service OEW, 48 PAX@95kg, JAR fuel reserves, taxi time allowance: 4min.